

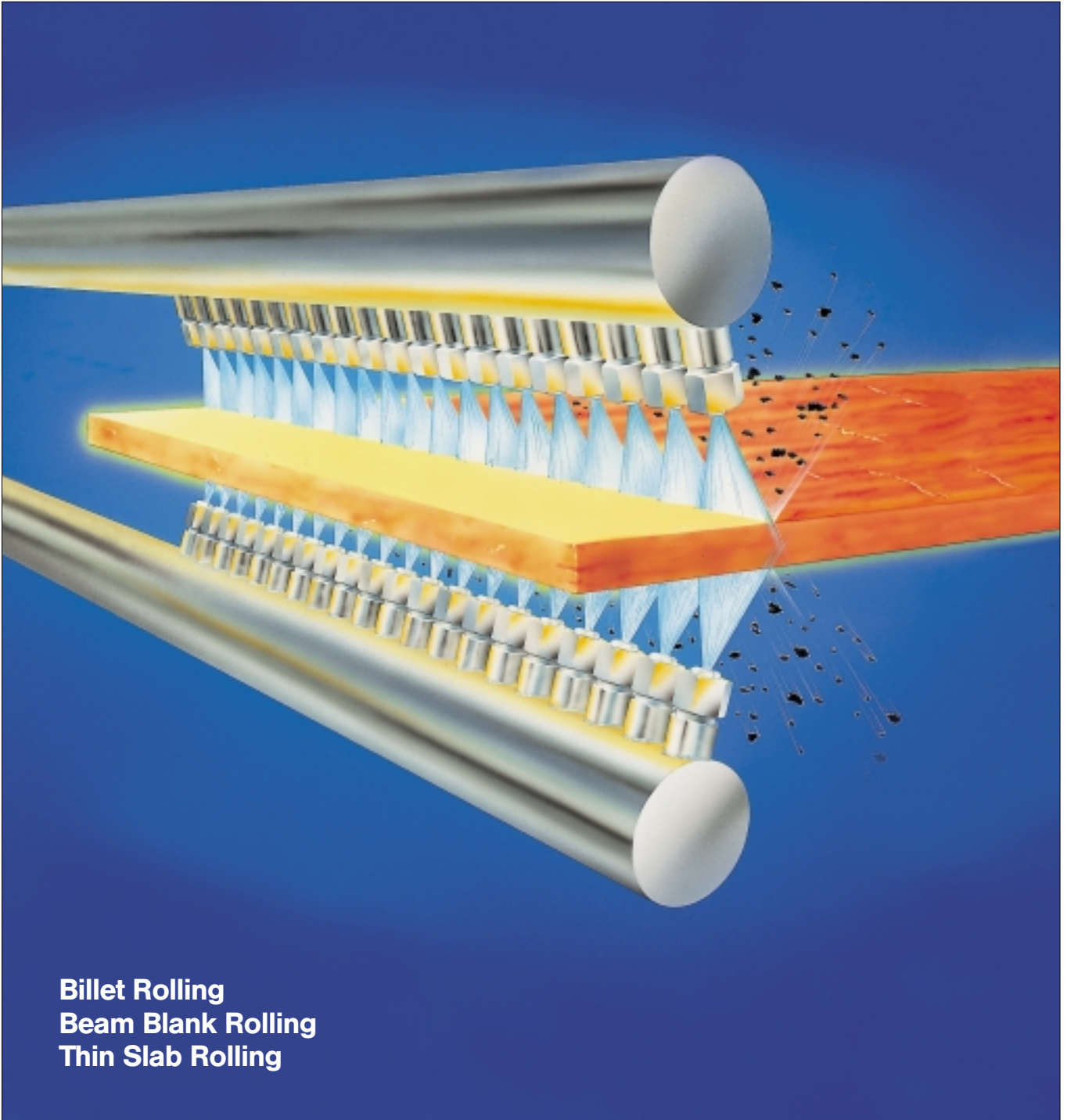

MiniSCALEMASTER®

Maximum Descaling for Thin Slabs
and Net Shape Profiles



Billet Rolling
Beam Blank Rolling
Thin Slab Rolling

MiniSCALEMASTER®

Small Nozzle – High Impact

New casting processes demand a new descaling approach. Thinner slabs and smaller cross sections need the most effective descaling with the least water to prevent overcooling. Now the leader in descaling technology has a better way.

MiniSCALEMASTER®, packs full sized power into the most compact package available. You can ensure complete descaling and the best surface finish your mill can produce every time. With the small holder and low profile, you can tuck a header into the tightest roll stands where you thought you would never have room. The MiniSCALEMASTER® is no mini performer. It uses the same orifice designs as its bigger brothers and can withstand the same pressures of our standard products. MiniSCALEMASTER®: perfect descaling of thin slabs, beams and billets.



Descaler in front of a rolling mill of a thin slab casting mill

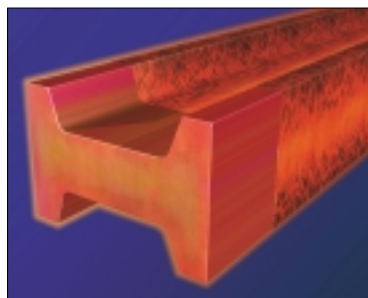

Beam partially descaled

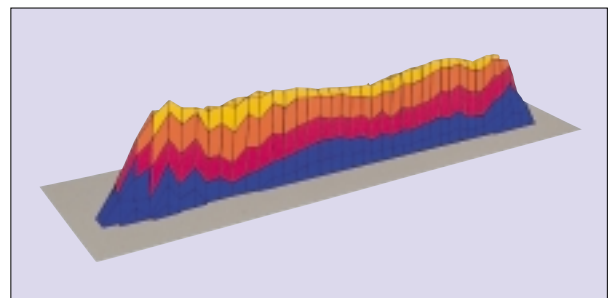

Three-dimensional representation of jet impact distribution

Small headers fit into tight spaces between stands

- Possibility of short spray distances, thus savings of water and/or energy
- Large flow rate selection for total liquid control
- Broad operating pressure range to meet varying production needs

MiniSCALEMASTER®

Minimum Cost Descaling

Positioning of nozzles on a spray header

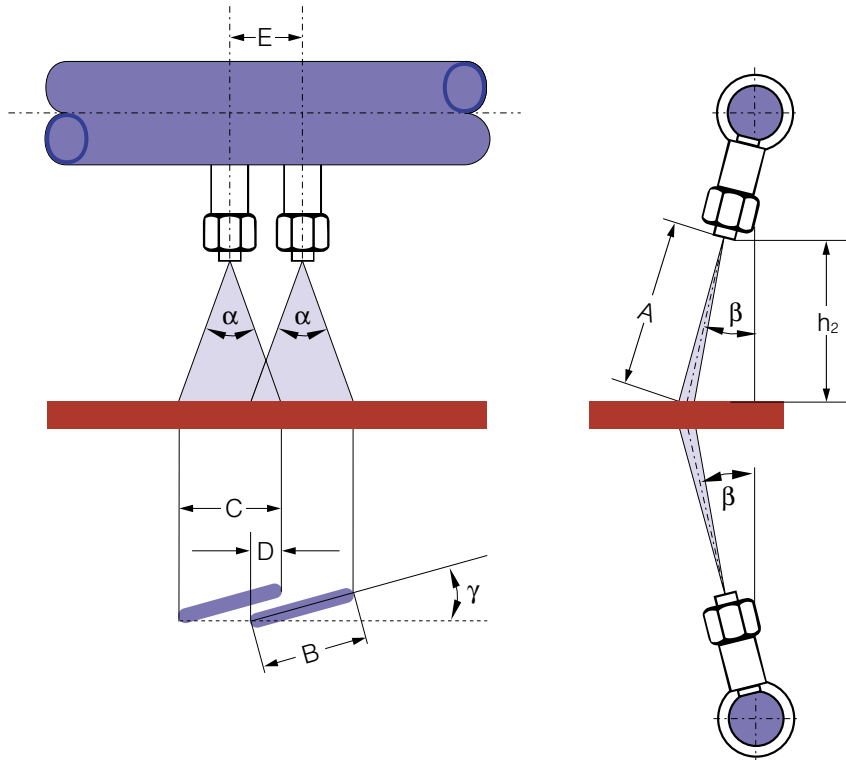

- A = spray length
- B = spray width
- C = spray width in rolling direction
- D = over lap
- E = nozzle distance
- h₂ = vertical spray height
- alpha = nozzle spray angle
- beta = angle of inclination
- gamma = offset angle of nozzle against pipe roll axis

Jet length (A), jet width (B,C), over lapping (D), nozzle distance (E) with vertical spray height (h₂), angle of inclination (beta) and nozzle spray angle (alpha)

Vertical spray height h ₂ [mm]	Angle of inclination beta = 15° A [mm]	Nominal Nozzle spray angle alpha at p = 150 bar															
		alpha = 22°				alpha = 26°				alpha = 30°				alpha = 40°			
		B	C	D	E	B	C	D	E	B	C	D	E	B	C	D	E
50	52	28	27	-	-	34	32,6	-	-	38	36,9	-	-	50	47,8	4	43,8
60	62	33	31,9	-	-	40	38,1	4	34,1 ¹⁾	45	43,3	4	39,3 ¹⁾	58	56,2	4	52,2
70	72	38	36,5	-	-	45	43,4	4	39,4 ¹⁾	51	49,4	4	45,4	67	64,4	4	60,4
75	78	40	38,8	4	34,8 ¹⁾	48	45,9	4	41,9 ¹⁾	54	52,3	4	48,3	71	68,3	4	64,3
80	83	43	41,1	4	37,1 ¹⁾	50	48,4	4	44,4	57	55,2	4	51,2	75	72,2	4	68,2
90	93	47	45,5	4	41,5 ¹⁾	55	53,1	4	49,1	63	60,9	4	56,9	83	79,8	4	75,8
100	104	52	49,8	5	44,8	60	57,7	5	52,7	69	66,3	5	61,3	90	87,2	5	82,2

1) only with hexagon socket nut

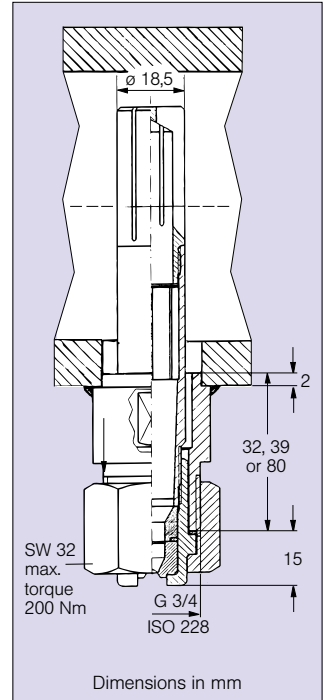

Assembled MiniSCALEMASTER®

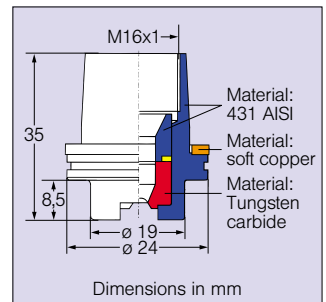

Cross section of nozzle

Explanation of the table

1. Spray width:

The convergence of the spray is considered in the listed values.

2. Tolerances of the spray angles:

+ 3° at alpha = 22°, 26° and 30°,
+ 5° at alpha = 40°.
Therefore C + D are minimum values.

Technical Data Flow Rate Chart Ordering Data



Lechler GmbH
Precision Nozzles - Nozzle Systems
P.O. Box 13 23
72544 Metzingen / Germany
Phone: +49 (0) 71 23 962-0
Fax: +49 (0) 71 23 962-333

E-Mail: info@lechler.de
Internet: www.lechler.de

Ordering No.							Volume flow (water)					
Series	Code				Mat.-No.		p = 100 bar (1450 psi)			p = 200 bar (2900 psi)		
	Spray angle				Stainl. Steel hardened	Tungsten carbide	[l/min]	[l/sec]	[US Gall./min]	[l/min]	[l/sec]	[US Gall./min]
	22°	26°	30°	40°								
644	495	496	497	498	○	-	12,00	0,20	3,17	16,97	0,28	4,50
644	535	536	537	538	○	○	15,00	0,25	3,96	21,21	0,35	5,60
644	565	566	567	568	○	○	18,00	0,30	4,76	25,46	0,42	6,73
644	605	606	607	608	○	○	23,00	0,38	6,08	35,53	0,59	9,39
644	645	646	647	648	○	○	28,00	0,47	7,40	39,60	0,66	10,46
644	685	686	687	688	○	○	36,00	0,60	9,51	50,91	0,85	13,45
644	725	726	727	728	○	○	45,00	0,75	11,89	63,64	1,06	16,81
644	765	766	767	768	○	○	58,00	0,97	15,32	82,02	1,37	21,67
644	805	806	807	808	○	○	72,00	1,20	19,02	101,82	1,70	26,90
644	845	846	847	848	○	○	89,00	1,48	23,51	125,87	2,10	33,25
644	885	886	887	888	○	○	112,00	1,87	29,59	158,39	2,64	41,85
644	905	906	907	908	○	○	125,00	2,08	33,03	176,78	2,95	46,70
644	915	916	917	918	○	○	134,00	2,23	35,40	189,50	3,16	50,07

Volume rate
conversion formula:

$$\dot{V}_2 = \sqrt{\frac{p_2}{p_1}} \cdot \dot{V}_1 \text{ [l/min]}$$

$$p_2 = \left(\frac{\dot{V}_2}{\dot{V}_1}\right)^2 \cdot p_1 \text{ [bar]}$$

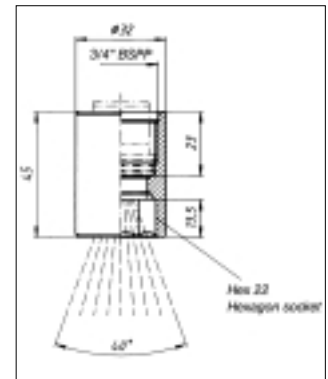

Special version of nut, with hexagon socket. For very short spray heights.

Ord.-No. 064.401.11

Dimensions

Type (spray angle 22°)	E ∅ [mm]	A ∅ [mm]	Type (spray angle 26°)	E ∅ [mm]	A ∅ [mm]	Type (spray angle 30°)	E ∅ [mm]	A ∅ [mm]	Type (spray angle 40°)	E ∅ [mm]	A ∅ [mm]
644.495	1,20	1,50	644.496	1,17	1,50	644.497	1,16	1,50	644.498	1,11	1,50
644.535	1,40	1,75	644.536	1,30	1,75	644.537	1,30	1,75	644.538	1,20	1,75
644.565	1,60	2,00	644.566	1,50	2,00	644.567	1,40	2,00	644.568	1,20	2,00
644.605	1,80	2,10	644.606	1,70	2,10	644.607	1,60	2,10	644.608	1,50	2,10
644.645	2,00	2,50	644.646	1,90	2,50	644.647	1,80	2,50	644.648	1,60	2,50
644.685	2,20	2,80	644.686	2,20	2,80	644.687	2,10	2,80	644.688	2,00	2,80
644.725	2,50	3,00	644.726	2,40	3,00	644.727	2,30	3,00	644.728	1,90	3,00
644.765	2,80	3,50	644.766	2,50	3,50	644.767	2,40	3,50	644.768	2,30	3,50
644.805	3,20	3,80	644.806	3,00	3,80	644.807	2,90	3,80	644.808	2,70	3,80
644.845	3,50	4,30	644.846	3,50	4,30	644.847	3,20	4,30	644.848	3,00	4,30
644.885	3,90	4,70	644.886	3,90	4,70	644.887	3,70	4,70	644.888	3,40	4,70
			644.906	4,00	5,00	644.907	3,90	5,00	644.908	3,70	5,00
			644.916	4,20	5,20	644.917	4,00	5,20	644.918	3,80	5,20

A = equivalent bore diameter · E = narrowest cross section

Example Series + Code + Mat.-No. = Ordering No.
for Ordering: 644 + 495 + 11 = 644.495.11

Component	Model	Ordering No.	Weight (kg)
Welding nipple	Length L:		
Material:	32 mm	060.020.1C.01	0,065
	39 mm	060.020.1C.00	0,082
	80 mm	060.020.1C.02	0,192
Jet stabilizer	without filter with cap	064.431.16	0,070
Material:	with filter S = 110	064.454.16	0,093
AISI 303	with filter S = 130	064.455.16	0,110
Gasket /Material: copper		095.015.34.02.07.0	0,001
Nozzle		644.xxx.xx see table	0,067
Nut (Hex 32) Material: AISI 431		064.400.11	0,085
Alignment tip /Blank tip/Material: Mild steel		064.490.01	0,056
Disassembly tool /Material: Mild steel	Data sheet on request	064.491.01	0,110
Tip Extractor	Data sheet on request	095.009.00.12.56.0	0,950

