

*ENGINEERING
YOUR SPRAY SOLUTION*



Precision Spray Nozzles and Engineered Solutions for the Chemical Industry



**Chemical and
Process Industry**

PROCESS OPTIMIZATION WITH NOZZLE TECHNOLOGY

On the one hand every company needs to develop and constantly optimize its production processes. In automated systems, even minor discrepancies can provide optimization opportunities. On the other side processes in the chemical industry are extremely complex and mutually dependent, each adjustment extends far beyond its immediate scope. That's why for over 135 years, Lechler provides nozzle and spray technology that always involves the understanding of all the processes involved.



Lechler is proud of a long history in the United States



Lechler can look back on a long and successful history in the United States. In 1975 Lechler purchased the Spray Engineering Company, manufacturer of Spraco spray products. Recognizing that Spraco is and has been an established name in the spray nozzle business, Lechler continues to make many Spraco products today.

As early as when his trading company was founded in 1879, Paul Lechler believed in chemistry. Initially the main focus was on technical products, machine oils and wood preservatives, and in 1905 the company gained exclusive sales rights to the protective coating Inertol®. By 1919 he had added his self-produced protective coatings to this portfolio. Later, our company's focus shifted from chemical production to application and atomization of liquids. In 1961,

all chemical products were finally combined in a separate company.

But nevertheless, chemistry kept playing a major role in our company. Today Lechler offers a wide product range for the optimization of technical processes. Throughout our history, chemistry has played a major role in our company. Over the course of many decades, this gave rise to a unique understanding of spraying and atomization processes.

We are familiar with a wide range of applications at various pressures, temperatures and atmospheres. The following pages will provide you with several examples of this.

1879



Company founded by Paul Lechler

1893



Patent for liquid atomization

1962



Sales offices set up in Germany

1978



Expansion into the USA, followed by further countries

COMPETENCE – THE ADVANTAGE OF MULTIPLE PERSPECTIVES

ENGINEERING
YOUR SPRAY SOLUTION



CUSTOMER ADVANTAGES

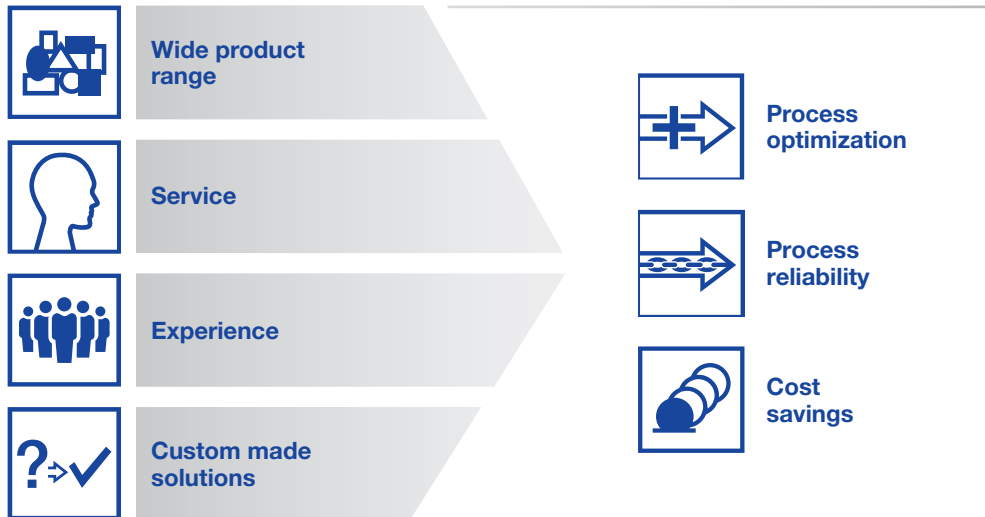

Maximum precision and highly reproducible spray patterns – that's what Lechler nozzle and spray solutions stand for. Today we not only supply a unique selection of readily available standard nozzles, but are also prepared, to develop individual solutions customized to your needs. We would also be very pleased to advise you in person about how you can make your own processes even more efficient.

Our competence

Lechler is world leader in nozzle and spraying technology. Our products and solutions are used worldwide in an extremely wide range of sectors – including the chemical and process industry.

Our application engineers are familiar with practical use from many successful applications, and are therefore competent partners in the development and realization of exemplary solutions.

This know-how combined with our sophisticated technical achievements in research, design and production, provides you with the security needed for safe and reliable plant operation.

Take us at our word and let's discuss your process needs in an obligation-free consultation.

Content	Page
Applications	4-21
Engineered solutions for process solutions	22-23
Nozzle lances and injectors	24-27
Lechler pump and control skids	28-29
Lechler mist eliminators	30-33
CFD analysis	34-35
Measuring technology	36-37
Precision nozzles	38
Spillback nozzles	39
VarioJet nozzles	40
Laval nozzles	41
Twin-fluid nozzles	42-43
Hollow cone nozzles	44-48
Full cone nozzles	49-64
Cluster head nozzles	65
Deflector-plate nozzle	66-67
Rotating cleaning nozzles	68-78
Quality with a system	79
For your notes	80

1988



Environmental Technologies division founded

1995



Production, sales and administration in Metzingen

2010



Opening of the new 13,000 m² production hall in Metzingen

2016



Opening of the new Development and Technology Center in Metzingen



LECHLER NOZZLES AND ENGINEERED SOLUTIONS – FROM THE WELL TO THE REFINERY

Whether pinpoint precision or broad coverage – spray solutions from Lechler perfectly support your processes at any point. Thanks to our profound process understanding Lechler is far more than just a nozzle manufacturer. In fact, we can help to optimize the efficiency of a large number of your processes. E.g. in the petrochemical industry from the well to the refinery.



Upstream

Applications

- Fire Suppression
- Dust Control
- Truck Cleaning
- Upgrader Froth Control
- Evaporation Ponds
- Waste Water Control
- Heat Exchanger Cooling



Midstream

Applications

- Corrosion Inhibitor Injection
- Bearing Grease Sprays
- Fire Suppression
- Additive Injection
- Storage Tank Cooling
- Hydrogen Scavenger Control
- Biocide Injection
- Glycol Injection
- Tank Cleaning
- Methanol Injection
- Rail Car Washing

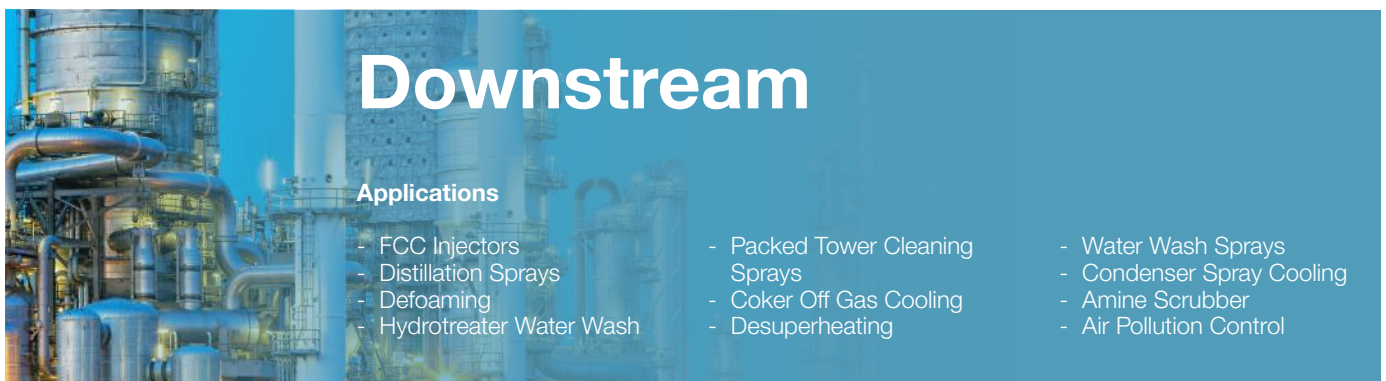

Downstream

Applications

- FCC Injectors
- Distillation Sprays
- Defoaming
- Hydrotreater Water Wash
- Packed Tower Cleaning Sprays
- Coker Off Gas Cooling
- Desuperheating
- Water Wash Sprays
- Condenser Spray Cooling
- Amine Scrubber
- Air Pollution Control



LECHLER NOZZLES AND ENGINEERED SOLUTIONS – AT HOME ALONG THE ENTIRE PROCESS LINE

Intense heat, high pressure, corrosive agents – every aspect of our nozzles has to be well defined right from the beginning in order to maintain the ultimate precision. This begins with the internal dimensions and doesn't end at the choice of the material. After the design phase every nozzle is rigorously examined in our test facilities. This way, we can ensure that the spray patterns of our nozzles match perfectly with the needs of your processes.



Basic Chemicals

Applications

- Heat Exchanger Sprays
- Desuperheating
- Rapid Quenching Sprays
- Plastic Fiber Cooling
- Granulation
- Pelletizer
- Fractionation



Specialty Chemicals

Applications

- Tank Cleaning
- Heat Exchanger Sprays
- Carbon Products Manufacturing
- Spray Drying
- Rapid Quenching Sprays
- Granulation
- Fire Protection
- Pelletizer
- Sulfuric Acid Regeneration
- Fuel Oil Spray
- Fractionation

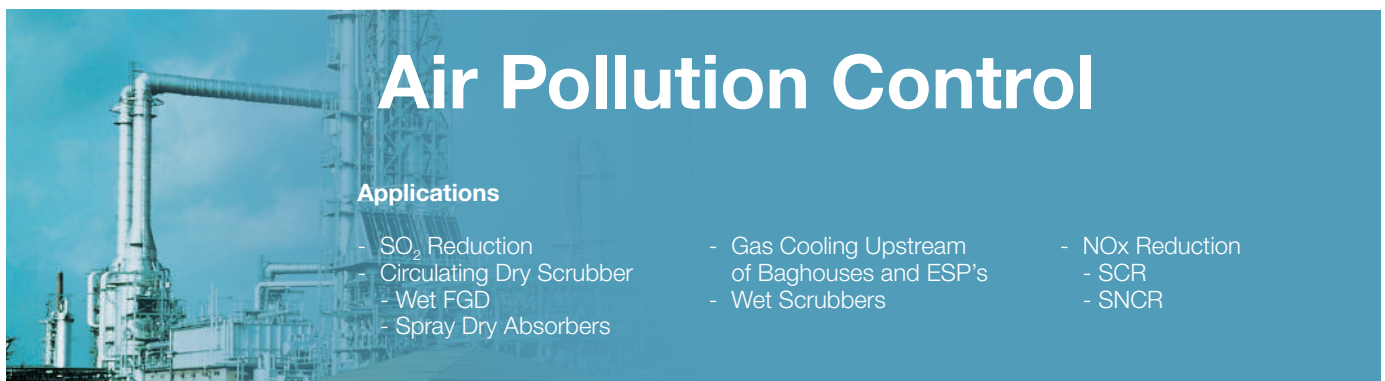

Air Pollution Control

Applications

- SO₂ Reduction
- Circulating Dry Scrubber
- Wet FGD
- Spray Dry Absorbers
- Gas Cooling Upstream of Baghouses and ESP's
- Wet Scrubbers
- NOx Reduction
- SCR
- SNCR

THIS IS WHERE YOU FIND YOUR ANSWER

The variety of different products synthesized and processed by the chemical industry is enormous. The same is true for the involved processes. Most of them are widely used and well understood. Others were specially developed and require extreme ambient conditions, occasionally customized to single reaction vessels.

Lechler supplies you in both areas with state-of-the-art nozzles and spray technologies.



Engineered Solutions for Process Applications



Precision Spray Nozzles

For large industry framework conditions special engineered solutions are necessary. That's why we also present to you additional Lechler customized products and solutions that we make only to order to meet the special needs of the chemical and petrochemical industry, e.g. pump and control skid units, lances, special nozzles, gas cooling and conditioning systems, mist eliminators and more. If you can't find what you're looking for, don't hesitate to contact us.

We would be happy to examine the possibilities available to us for developing the optimum atomization nozzle to suit your needs – custom made and in close collaboration with you. Please note the production related delivery times and costs for the nozzles presented here.

- Customized products and solutions
- Tailored to your needs
- Extensive consultation
- Individual design and process support

For most applications, our precision spray nozzles will provide excellent results.

These parts have not only been meticulously designed but also have stood the test of time. Thanks to large-volume production, they are readily available at a reasonable price for the various applications in chemical-related applications. In this brochure you'll find our most commonly used products.

- Thousands of standardized nozzles
- Tried and tested
- Great value for money
- Short delivery time

LECHLER NOZZLES AND ENGINEERED SOLUTIONS ARE USED IN MANY FIELDS IN THE CHEMICAL INDUSTRY

Tank sprinklers and fire protection

For cooling and sprinkling tanks and systems, it is extremely important to spray the entire object with water on all sides or to provide an even water film on the object. The narrowest cross section of the nozzles should be $\geq .24$ in (DIN 14495). **Tongue-type nozzles** and **full cone nozzles** are frequently used.

Mist eliminators

Droplets can be carried along in the gas flow. Lechler **mist eliminators** remove droplets from the gas flow in order to prevent down-stream measuring devices from being affected. Special **full cone nozzles** are available for cleaning mist eliminators.

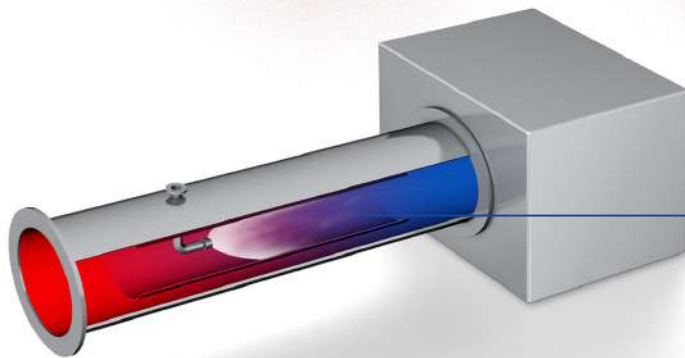
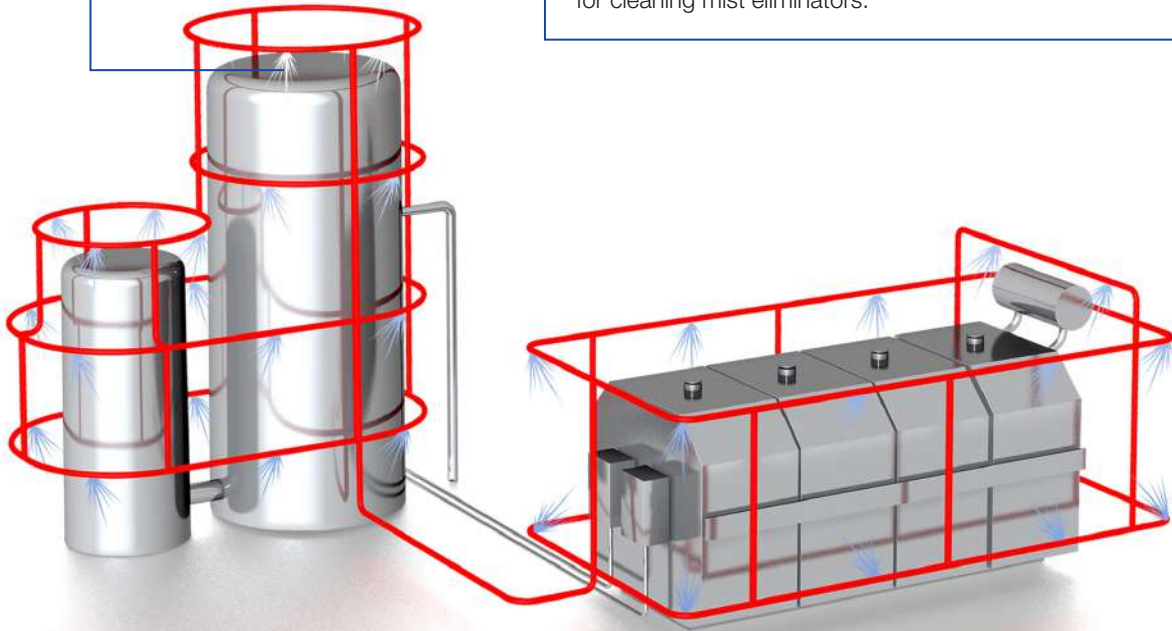

Gas cooling (Quenching)

In gas cooling, a liquid is added via nozzles that, under some circumstances, evaporates completely and thereby absorbs the thermal energy of the gas. Complete evaporation requires very fine droplets which can be produced with **hollow cone** or **twin-fluid nozzles**.

Absorption (Gas washing)

If the waste gas is to undergo absorption, Lechler **full cone**, **hollow cone**, or **cluster nozzles** are used. It is of crucial importance here to create a large specific reaction surface. The efficiency of the process can be decisively enhanced by making the right nozzle selection and having an optimum nozzle arrangement.



Material separation in centrifuges

Centrifuges are used to separate materials. **Full cone** and **flat fan nozzles** are used for this purpose to spray water on and wash out the material that is to be removed.

Examples engineered solutions

Mist eliminators



- Arrest finest droplets (<math><10\mu\text{m}</math>)
- Little pressure loss
- For high flow rates

Nozzle lances and injectors



- Optimal spray placement
- Individual adapted
- Several options

Examples spray nozzle solutions

Full cone nozzles – series 490

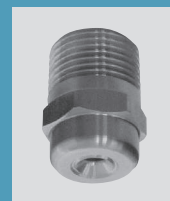

- Non-clogging design
- Stable spray angle
- Particularly even spray distribution

Twin-fluid nozzles

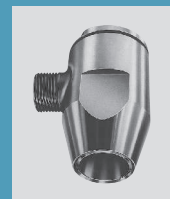

- Very fine droplets
- Smallest flow rates
- Atomizing viscous liquids

LECHLER NOZZLES AND ENGINEERED SOLUTIONS ARE USED IN MANY FIELDS IN THE CHEMICAL INDUSTRY

Cleaning containers

Optimum container cleaning requires targeted harmonization with the customized application. Lechler offers a wide range of **nozzles for tank and equipment cleaning** and will support you in finding the right arrangement.

System and large tank cleaning

High impact tank cleaning machines can be used in this application. These traverse a precisely defined path with **gear-controlled solid stream nozzles**. This gives them a great range. In smaller containers and systems, the precision jets can remove even persistent dirt.

Nozzles for air cooling and humidification

The thermodynamic processes of evaporation are normally applied in air cooling and humidification. This requires fine droplets that are injected directly into the air/gas flow by **hollow cone** or **cluster nozzles**. Producing the suitable droplet size and even distribution over the intake channel are particularly important here.

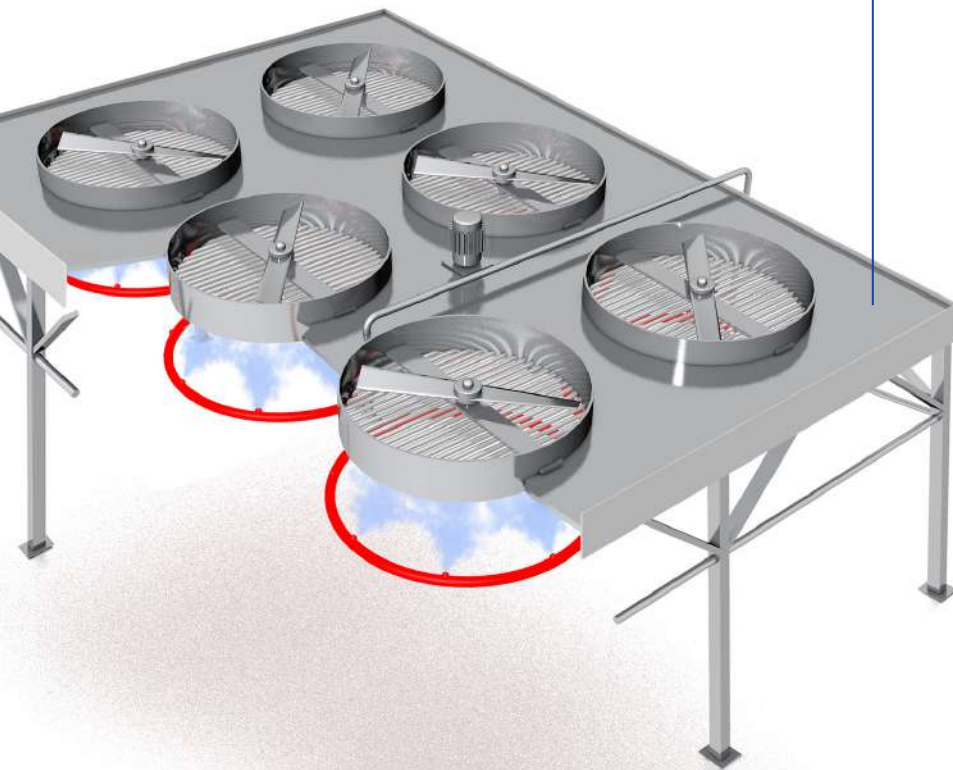

Examples engineered solutions

Tank lances

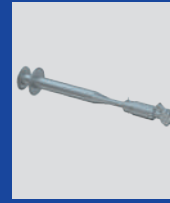

- Fully customized tank lance
- Different materials
- Different connection types

Spray headers

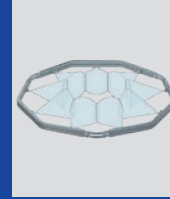

- Fully customized spray headers
- Different materials
- Twin-fluid nozzles possible

Examples spray nozzle solutions

High impact tank cleaning machine – series 5T2 / 5T3 / 5TB / 5TM



- Powerful solid jets – highest impact
- For persistent soil
- Robust and proven construction

Free spinning tank cleaning nozzles – series 569



- Popular and proven
- Effective flat jets
- ATEX-approved version

Cluster nozzles – series 502 / 503

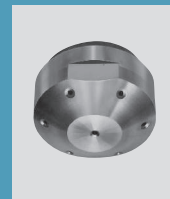

- Full cone like distribution
- Small droplets

LECHLER NOZZLES AND ENGINEERED SOLUTIONS ARE USED IN MANY FIELDS IN THE CHEMICAL INDUSTRY

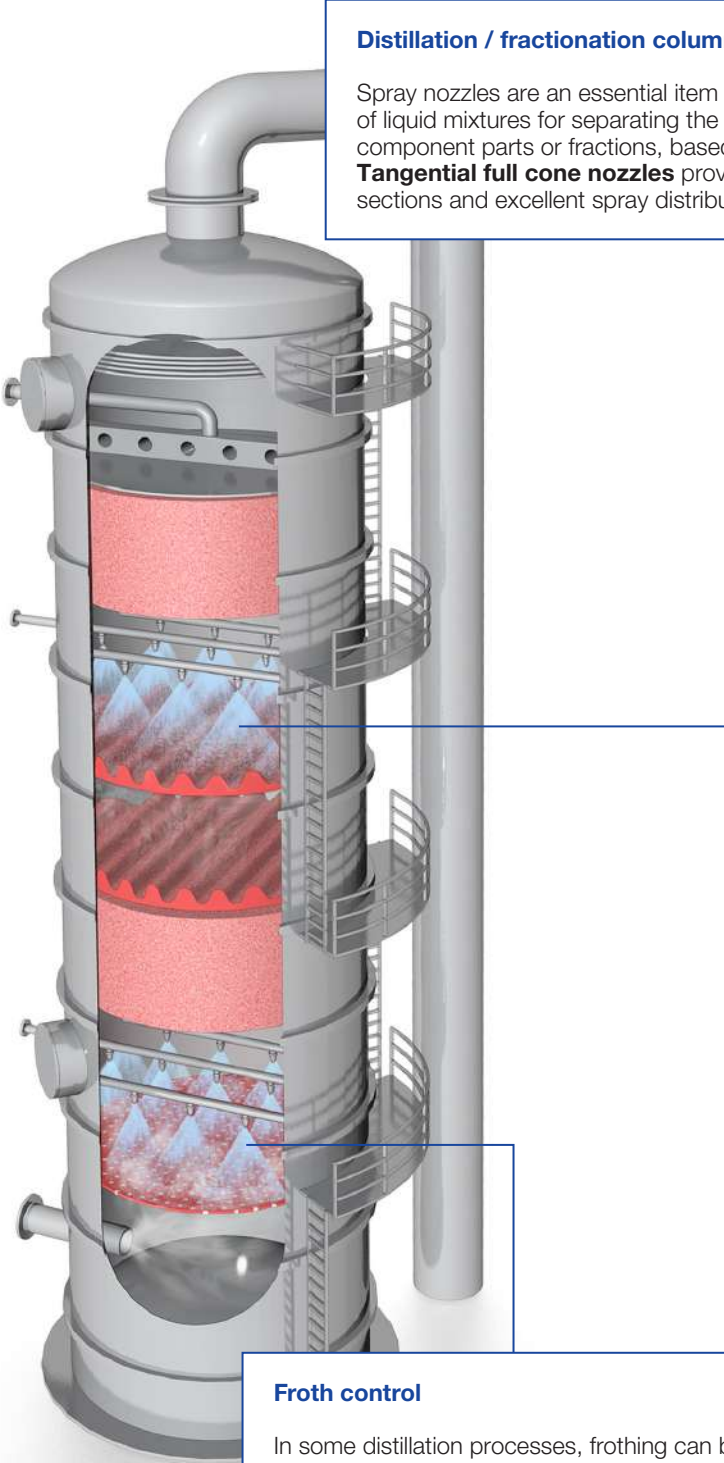

Distillation / fractionation column

Spray nozzles are an essential item used in distillation of liquid mixtures for separating the mixture into its component parts or fractions, based on the volatilities. **Tangential full cone nozzles** provide large free cross sections and excellent spray distribution for this task.

Froth control

In some distillation processes, frothing can be a problem that occurs throughout. **Full cone nozzles** are used to control the foam because they provide full uniform spray coverage.

Steam condenser sprays

These types of heat exchangers convert steam from its gaseous state to a liquid state by using **full cone nozzles**. These nozzles provide good spray coverage for the large area with the greatest pump efficiency.

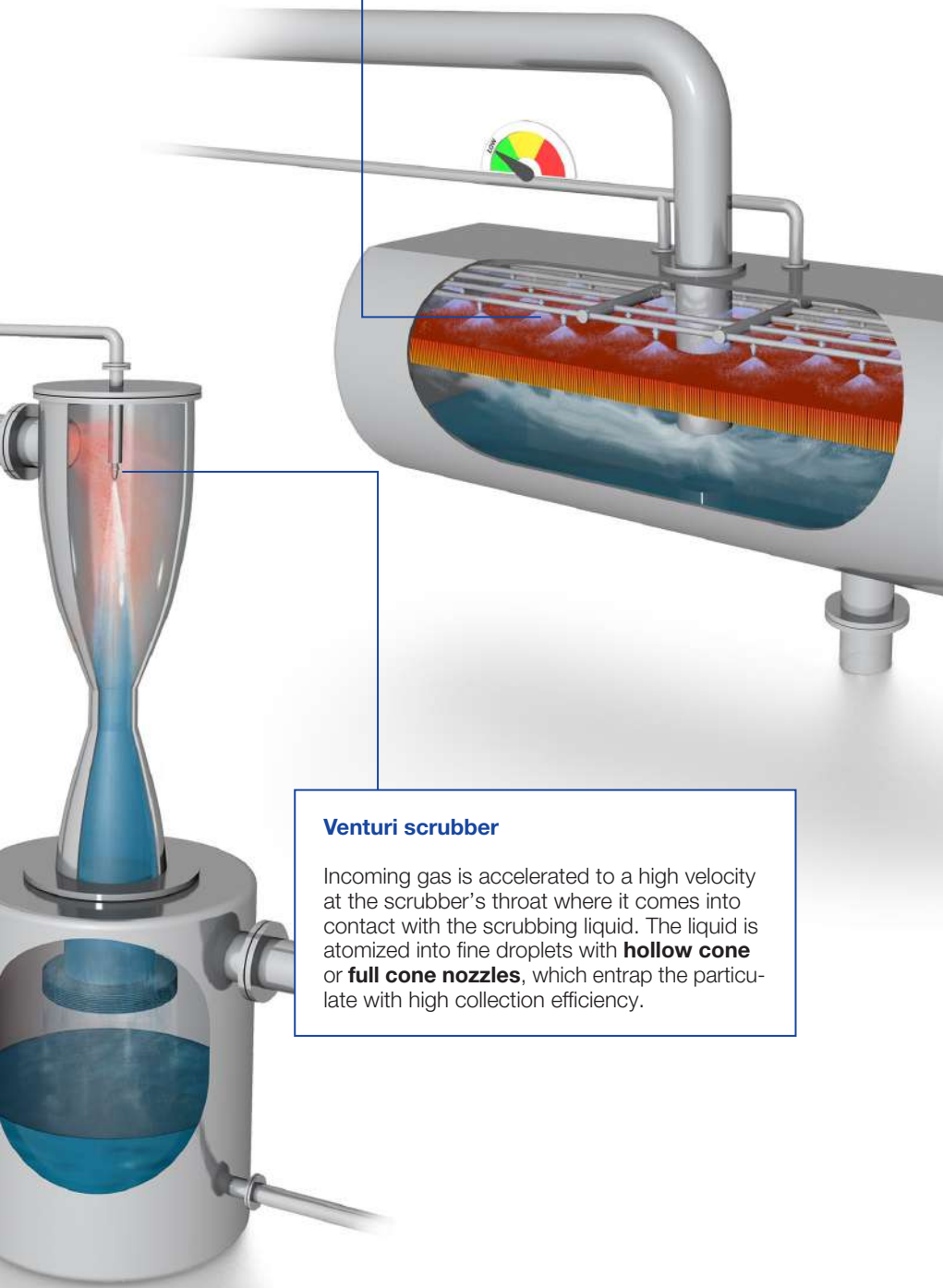

Venturi scrubber

Incoming gas is accelerated to a high velocity at the scrubber's throat where it comes into contact with the scrubbing liquid. The liquid is atomized into fine droplets with **hollow cone** or **full cone nozzles**, which entrap the particulate with high collection efficiency.

Examples engineered solutions

Nozzle lances and injectors



- Optimal spray placement
- Individual adapted
- Several options

Pump and control skid units



- High-quality components
- Tested quality
- Perfectly tailored solution

Examples spray nozzle solutions

Tangential full cone nozzles – series 422 / 423

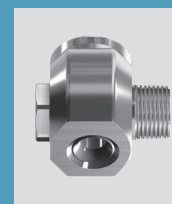

- No swirl insert
- Non-clogging
- Stable spray angles

Full cone nozzles – series 403 / 405

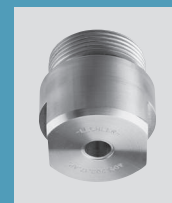

- High flow rates
- Even spray distribution
- Big droplets

LECHLER NOZZLES AND ENGINEERED SOLUTIONS ARE USED IN MANY FIELDS IN THE CHEMICAL INDUSTRY

Evaporative gas cooling

Cooling hot gas with water using **twin-fluid nozzles** to increase the surface area and speed of evaporation. Additionally the process can be controlled with a Lechler pump and control skid **VarioCool®**.

Feedstock oil

This heavy oil is injected into the reactor and the end result is a dry carbon product. **Full cone nozzles** with large free cross section are most suitable for this application.

Fuel burner

A small **hollow cone nozzle** sprays fuel oil to produce the high temperatures required by the reactor.

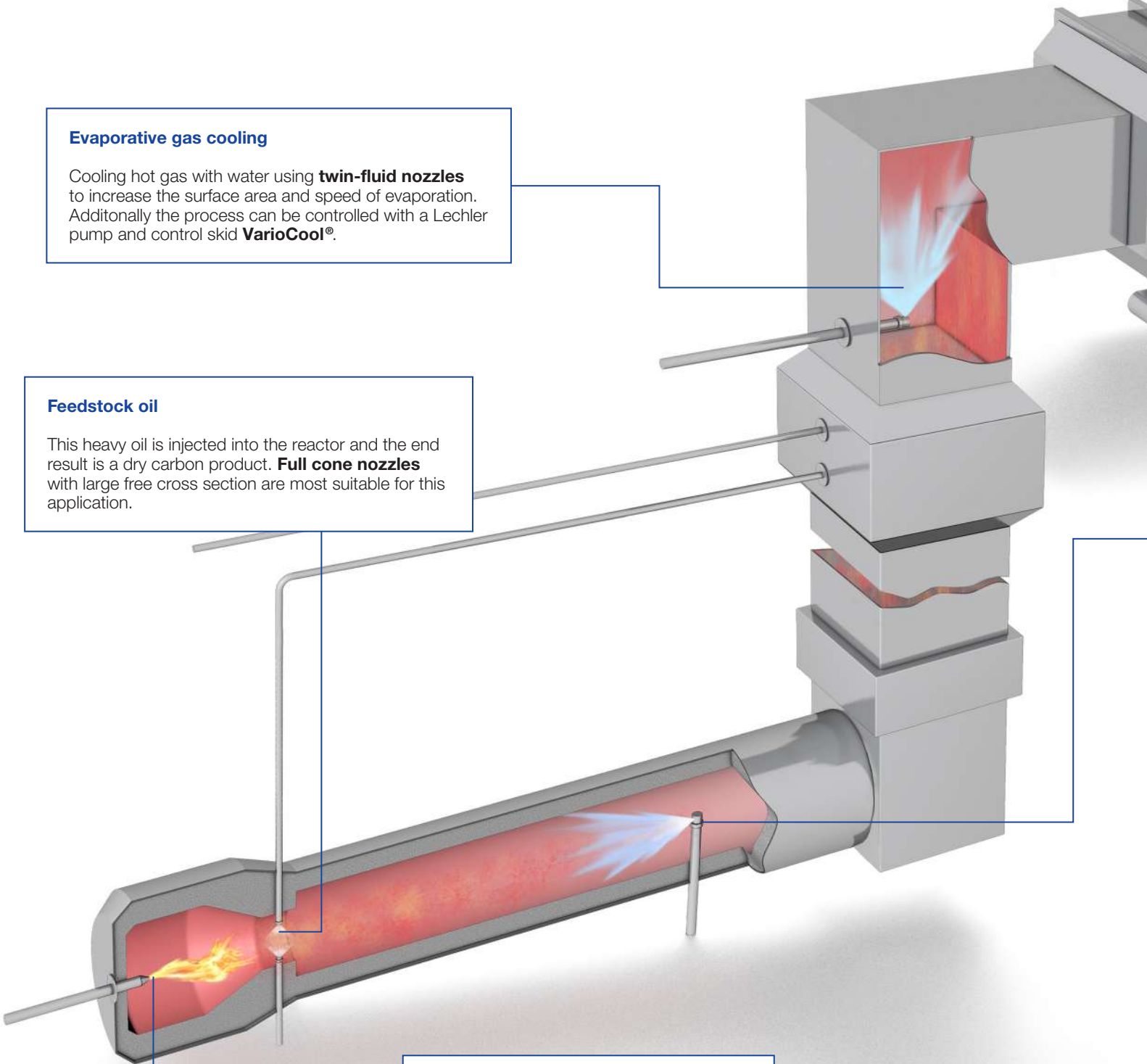

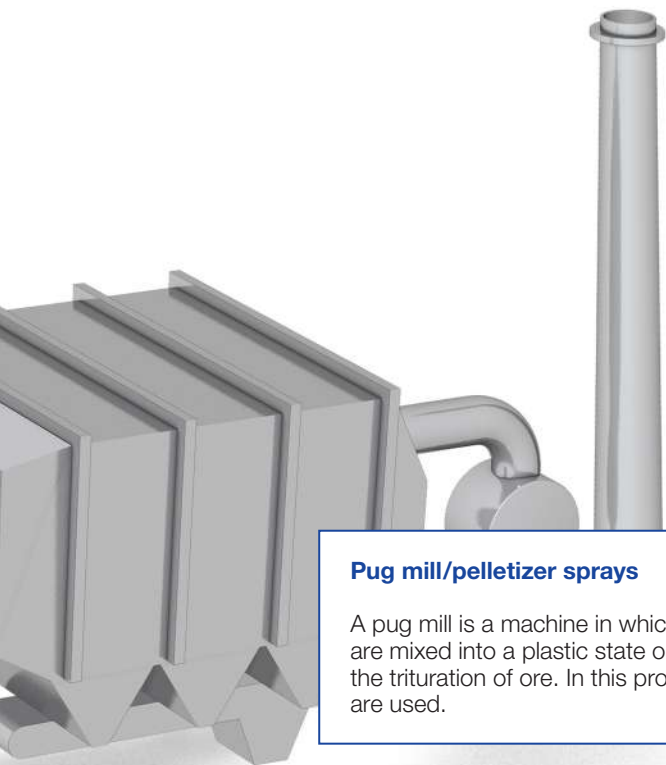

Pug mill/pelletizer sprays

A pug mill is a machine in which clay or other materials are mixed into a plastic state or a similar machine for the trituration of ore. In this process **full cone nozzles** are used.

Quenching water

It is key in many chemical processes to rapidly quench the temperatures to control product output. **Hollow cone nozzles** are used for quenching because they produce fine droplets.



Examples engineered solutions

Nozzle lances and injectors



- Optimal spray placement
- Individual adapted
- Several options

Pump and control skid units



- High-quality components
- Tested quality
- Perfectly tailored solution

Examples spray nozzle solutions

Hollow cone nozzles – series 214 / 216 / 218



- Small droplets
- Low flow rates

Twin-fluid nozzles – series 170 / 180



- Efficient atomization
- Extremely fine atomization
- Large free cross sections

Twin-fluid nozzles – VarioJet®



- Internal mixing
- Innovative design
- Very fine droplet spectrum

LECHLER NOZZLES AND ENGINEERED SOLUTIONS ARE USED IN MANY FIELDS IN THE CHEMICAL INDUSTRY

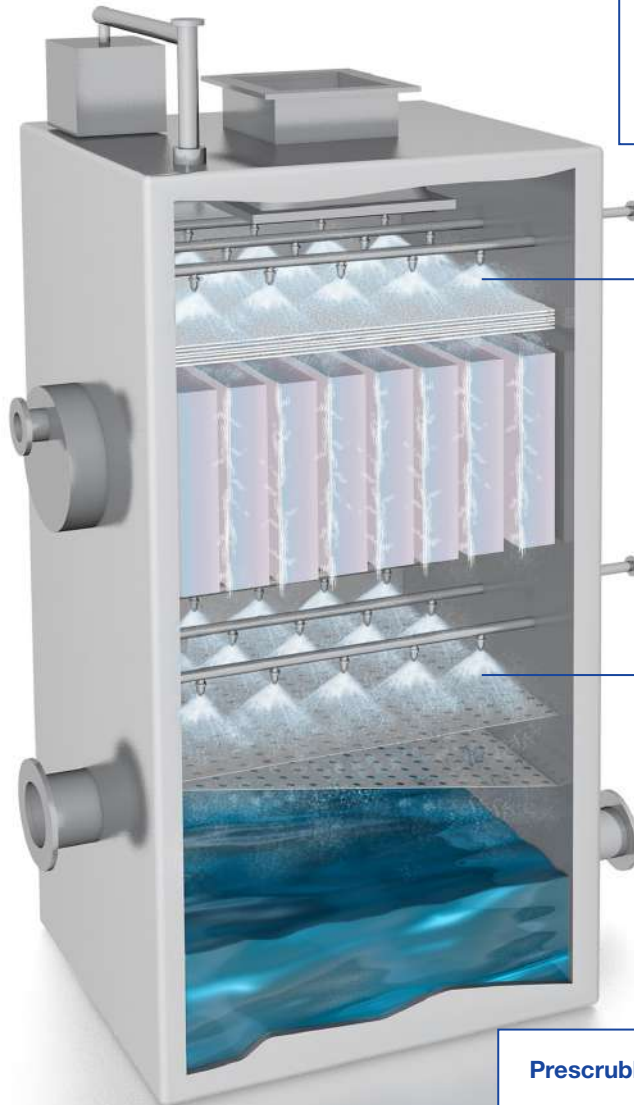

Particulate washing

An electrostatic precipitator (ESP) is a filtration device that removes fine particles from a flowing gas using the force of electrostatic charge minimally impeding the flow of gases through the unit. **Full cone nozzles** are used to wash the collected particulate from the collecting tube or plate.

Prescrubbing and gas cooling

At the bottom of the wet ESP, above the gas distribution plates **hollow cone** and **full cone nozzles** are used in the vessel for pre-cleaning, gas cooling, scrubbing and particulate removal.



Water washing of salts

These injectors use **full cone nozzles**, which are used to scrub salt-forming contaminants from preflash and atmospheric tower overhead systems before they react and cause corrosion.

Examples engineered solutions

Mist eliminators



- Arrest finest droplets (<math><10\mu\text{m}</math>)
- Little pressure loss
- For high flow rates

Nozzle lances and injectors



- Optimal spray placement
- Individual adapted
- Several options

Spray headers

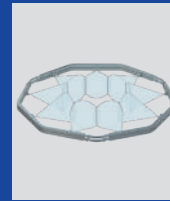

- Fully customized spray headers
- Different materials
- Twin-fluid nozzles possible

Examples spray nozzle solutions

Full cone nozzles – series 490

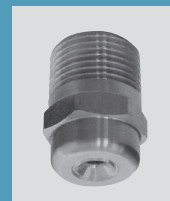

- Non-clogging design
- Stable spray angle
- Particularly even spray distribution

Hollow cone nozzles – series 214 / 216 / 218



- Small droplets
- Low flow rates

LECHLER NOZZLES AND ENGINEERED SOLUTIONS ARE USED IN MANY FIELDS IN THE CHEMICAL INDUSTRY

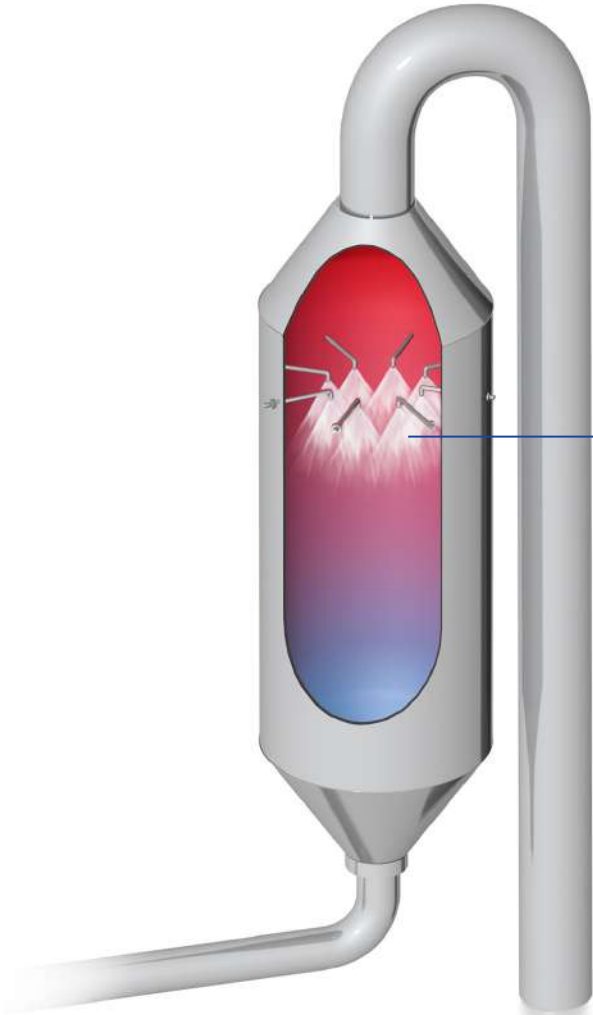

Gas cooling tower

Precise cooling and conditioning of hot flue gases create stable outlet conditions for the safe and efficient operation of downstream plant components. Lechler is offering a wide range of **engineered solutions** to control the outlet conditions of a gas cooling tower.

SNCR NOx reduction

The selective non-catalytic reduction (SNCR) is an industrial technique for NOx reduction. **Twin-fluid or flat fan nozzle lances** spray fine droplets of urea or aqueous ammonia directly into a furnace.

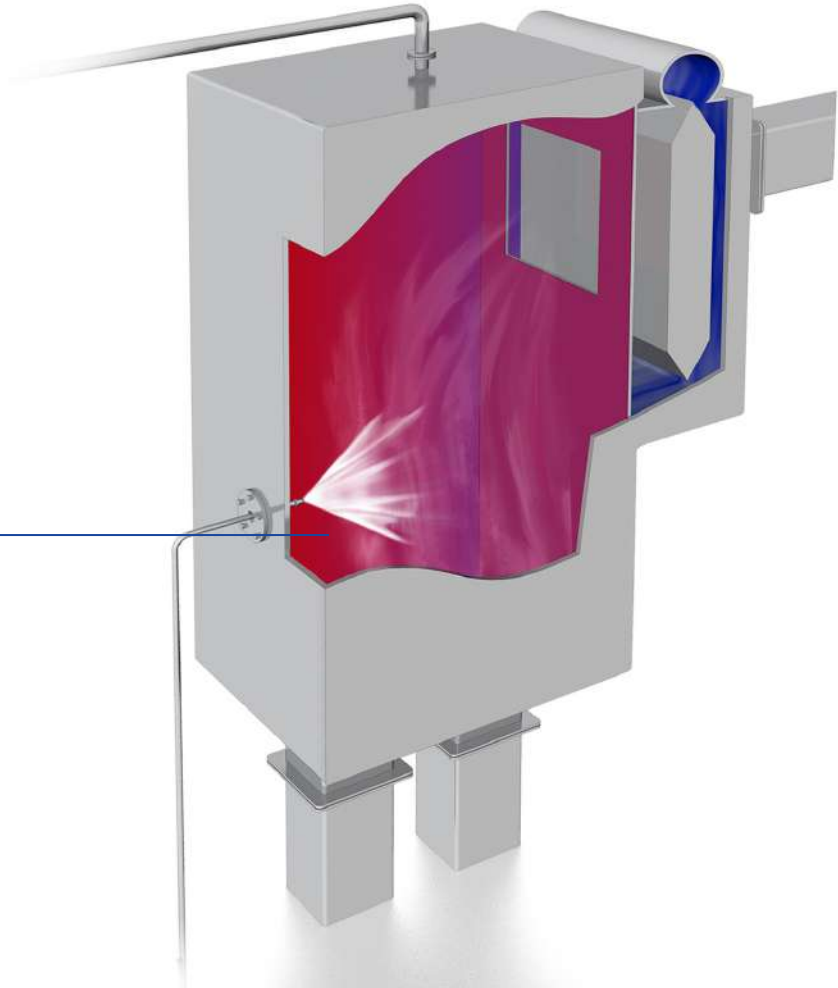

NOx reduction with SCR

With the selective catalytic reaction (SCR), achieving a high separation efficiency is possible only with the aid of a catalyst. Such a solution requires special precautions to keep the efficiency high and catalyst waste low. The reagent is added immediately before the catalyst using **twin-fluid nozzle lances** in a temperature window appropriate to the reaction.

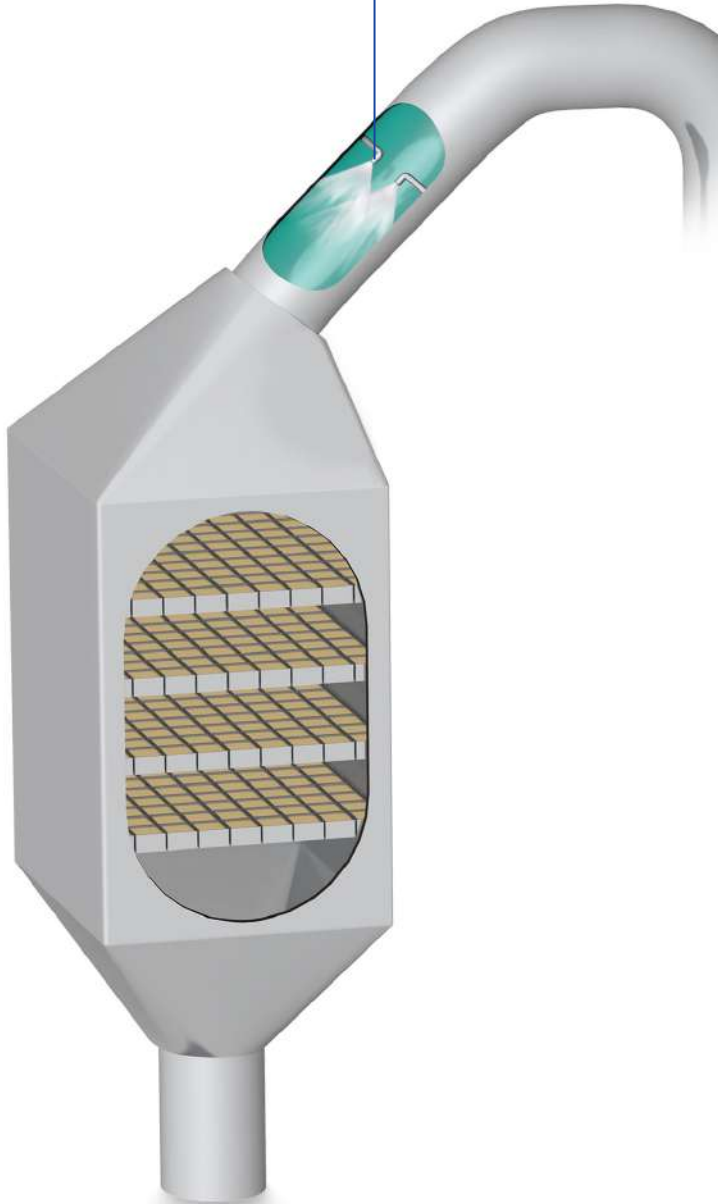

Examples engineered solutions

Nozzle lances and injectors



- Optimal spray placement
- Individual adapted
- Many options

Pump and control skid units



- High-quality components
- Tested quality
- Perfectly tailored solution

Examples spray nozzle solutions

Spillback nozzles



- Fine hollow cone atomization
- Constant pressure
- No compressed air

Twin-fluid nozzles – Laval



- Fine full cone atomization
- Droplet size and spectrum can be adapted
- For high temperatures



ENGINEERED SOLUTIONS FOR PROCESS SOLUTIONS: SOPHISTICATED SOLUTIONS FOR ADVANCED APPLICATIONS

If you are breaking new ground there is no standard solution available. But that's no problem. With our decade-long experience we are able to develop customized nozzles, spray systems and mist eliminators on short hand. Let's talk and find your perfect solution.



NOZZLE LANCES AND INJECTORS FOR HIGHEST SPRAY ACCURACY

Design features

Connection accessories

- Quick release coupling
- Conical screw connection
- According to customer requirements

Protection features

- No protection features
- With protection tube and cap
- According to customer requirements

Nozzle arrangement

- Single nozzle
- Cluster head

Flange connections

- Wedge
- Standard flange e.g. DIN, ANSI etc.
- According to customer requirements

Multi nozzle lances

- Number of nozzles according to customer requirements

Lechler nozzle lances ensure optimal spray placement and alignment in flue gas ducts. The choice of nozzles and the consideration of local conditions and process-related matters mean they can be individually adapted to the respective requirements.

The nozzles themselves have a low-maintenance design and can be quickly cleaned or exchanged with minimal effort.

The robust, high-quality stainless steel construction ensures a high degree of functional

reliability. Lances are available in a variety of materials to suit specific process requirements.

Lechler nozzle lances are available with many options, including but not limited to:

- Protection tube to increase the service life in case of higher temperatures, high dust loads and aggressive gases, with barrier air as an option.
- Wedge flange, standard flange and special flange in accordance with customer requirements
- Guide rail to facilitate lance installation

- Shifting device to change the insertion length – with or without gas tight sealing
- Expansion joint or stuffing box for expansion compensation at high temperatures
- Assembly connecting piece with flange connector for welding onto flue gas duct
- Further special customizations including wear protection, insulation, water cooling or coating
- Pre-assembled accessory kits for process media connections (e.g. quick release couplings, shut-off ball valves, strainers)

Lechler nozzle lances are manufactured in line with ultramodern production processes and according to the state of the art.

Material

Lances are manufactured from stainless steel (316/316L) as standard, but depending on requirements can also be made of chemical and high-temperature resistant materials.

Accessories are available in galvanized steel or stainless steel and the hoses are available in rubber or stainless steel.

Meeting customer requirements

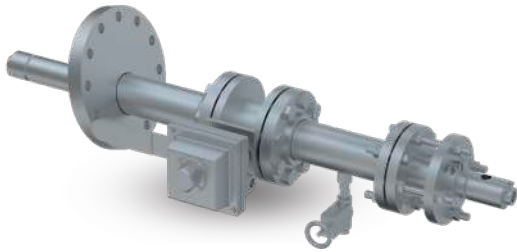

Catalyst retractable lance



Neutralizer retractable lance

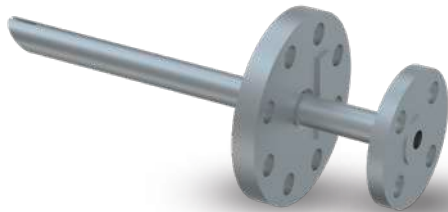

Liquid injection sparger

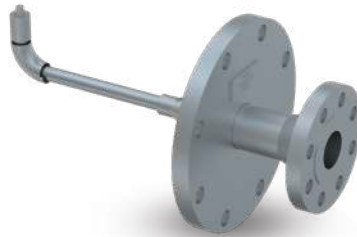

Water wash injector



Water wash injector

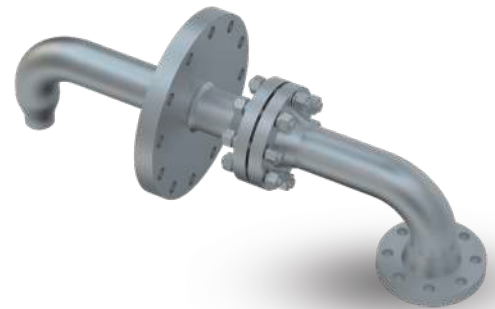

Chemical injection quill

Mounting example

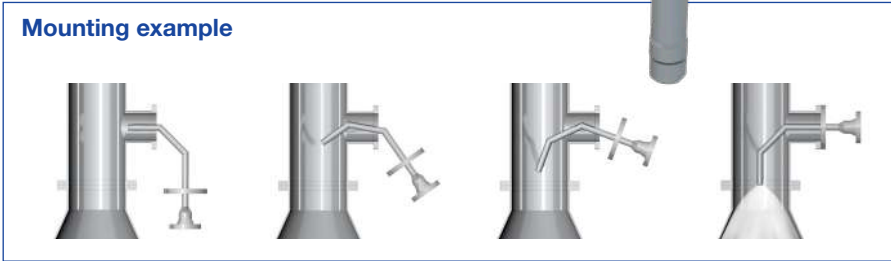

Nozzle lances and injectors

Taylor made solutions

Lance injector type

Material and test requirements and standards

Connection type and features

Hydraulic

Material Selection

- Stainless Steel 316L
- Hastelloy
- PP, PVC
- And many more

Flange connections

- Wedge
- Standard flange e.g. DIN, ANSI etc.
- Special flange according to customer specification

Twin-fluid air/liquid

Code Compliance

- ASME B31.1 Power Piping code
- Metallic industrial piping: DIN EN 13480
- Unfired pressure vessels: DIN EN 13445
- ASME B31.3 Process Piping code
- Welder Performance Qualification Records per ASME BPVC section IX
- Qualification test of welders: DIN EN 287

Additional features

- Shifting device to change the insertion length – with or without gastight sealing
- Expansion joint or stuffing box for expansion compensation at high temperatures
- Pre-assembled accessory kits for process media connections (e.g. quick release couplings, shut-off ball valves, strainers)
- Further special customizations including wear protection, insulation, water cooling or coating
- Assembly connecting piece with flange connector for welding onto flue gas duct
- Guide rail to facilitate lance installation

Steam

Testing

- ANSI and ASTM testing
- Non-destructive testing – Penetrant testing: DIN EN ISO 3452
- Hardness
- Hydrostatic pressure test: Pressure Equipment Directive 2014/68/EU, DIN EN 13480-5 and DIN EN 13445-5
- Spray and flow testing
- Phase Doppler Anemometry (PDA) measurement system
- Magnetic particle inspection: DIN EN ISO 17638
- Positive Material Identification

Injector/lance arrangement

Nozzle type

According to customer requirements

- Spray direction
- Insertion length
- Single nozzle
- Multi-nozzle arrangement
- Cluster head design

Nozzle type selection

- Hydraulic nozzles
- Twin-fluid nozzles



Spargers and Quills

- According to customer requirements

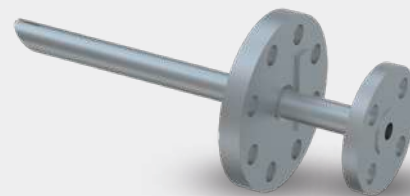

PUMP AND CONTROL SKIDS

A PERFECTLY TAILORED SOLUTION

Our pump and control skid units for regulating the flow rates of water and atomizing air are individual customer-specific solutions. Based on the requirements in each case, our first step is to design an overall concept and select the best components in order to create a perfectly tailored solution.

First-class engineering

To perform our engineering, we determine all relevant parameters and define the plant's design. This includes determining the nominal widths and pressure levels as well as designing the pumps and control valves. We draw up the P&I diagram and make detailed equipment and signal lists as an option. Of course, the project is fully documented to ensure that technology and processes can be quickly traced even after years of use.

High-quality components

An exact knowledge of the characteristic properties of our nozzles is key here. Only a complete system that is coordinated to how the nozzles function and operate will ensure smooth and economical operation of the gas cooling system. Unexpected failures can quickly lead to plant stoppages and costly production outages. This is why we fit our pump and control skid units with high-quality components from well-known manufacturers as standard and the most important functional components are even realized in redundant design.

The components are interconnected with pipes and mounted on a stable base frame with eyelets for crane transportation, at the same time ensuring that all components for operation and maintenance are arranged in an easily accessible manner.

Tested quality

The design (e.g. dimensioning of nominal widths) and production are in line with the latest state of the art and comply with all relevant standards. They are equally subject to the Lechler quality management system certified to DIN EN ISO 9001, as is the final acceptance. Before delivery, the pump and control skid unit undergoes a pressure and tightness test and is checked by our experienced engineers. This will avoid any problems during commissioning.

Control concept from the nozzle specialist

Numerous installations of VarioCool® systems, years of commissioning experience, plus expertise in nozzle technology all contribute to the constant improvement and optimization of Lechler control systems. By installing a control solution from Lechler you will benefit considerably from this wealth of experience. The flexible and fully automatic concept can be perfectly adapted to your process. You will have start-up and shut-down scenarios and dynamic process conditions under perfect control with our solution.

Option packages for our VarioCool® pump and control skid

Electrical wiring of the components:

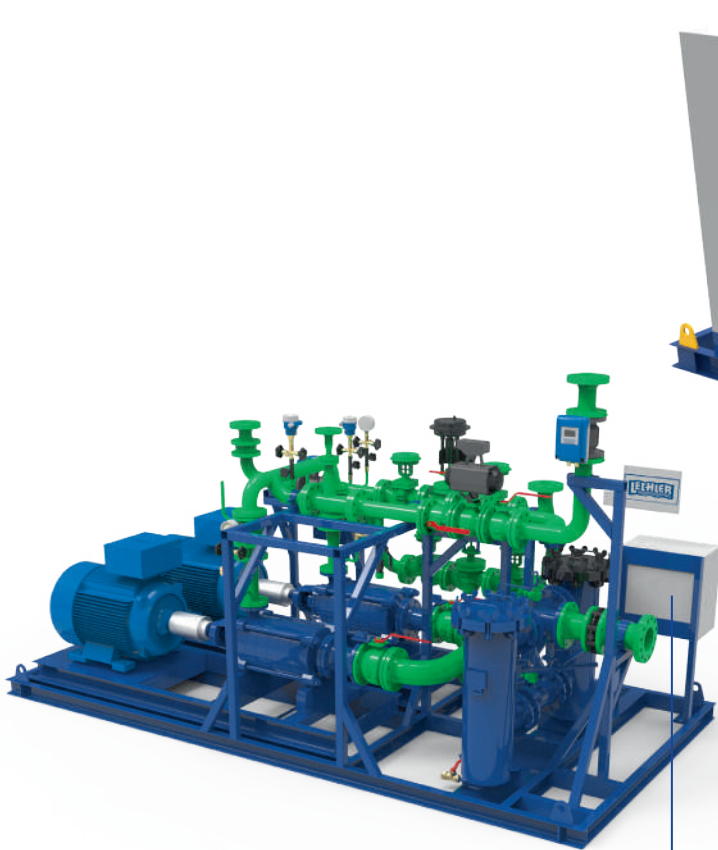

Junction box

All components except the pump motors are wired to a junction box within the pump and control skid unit.

This assures that the customer has a central connection point for all electrical components and measuring devices for further processing in the higher-level control.

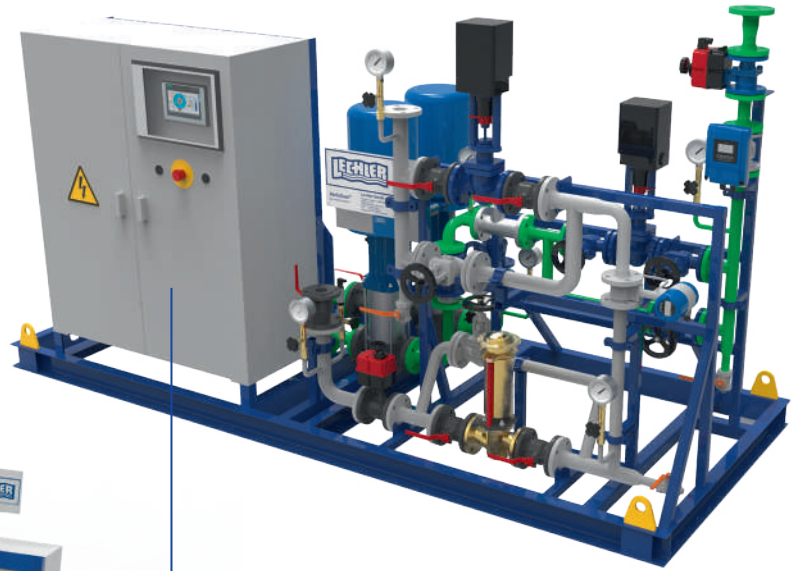

Control cabinet with complete PLC

All components including the pumps are wired to a control cabinet. The control cabinet is integrated into the base frame of the pump and control skid unit.

The complete injection control is tested in accordance with valid electrical standards and regulations and allows all relevant process parameters to be visualized over a control panel on the control cabinet.

Specific configuration and extensive testing make commissioning much faster. Communication and the exchange of signals (setpoint, plant status, error messages) with the customer's logic system is carried out via PROFIBUS or PROFINET.

The control has several modes of operation such as automatic mode and manual mode for tests during plant downtimes. In the event of faults, our engineers can quickly perform a remote diagnosis via the installed modem without the need for an on-site visit.



Talk to us

Customer requirements are different. Which is why standard solutions do not always make sense. Speak with us and let us work together to find the best solution for your purposes.

MIST ELIMINATORS WHEN PERFORMANCE COUNTS

Mist eliminators have played a vital role in many process operations and gas washing plants as functional elements that protect downstream installation parts, increase product yield or reduce energy consumption. They are now becoming even more important due to increasingly stringent environmental protection regulations that require a drastic reduction in the residual pollutant content.

This makes it necessary to use high-performance mist eliminators which are capable of separating even the finest droplets with a size of less than 10 microns, while at the same time minimizing pressure losses. This task requires effective separation systems with compact dimensions that can deal with high flow rates.

When designing and planning mist eliminators, it is necessary to have precise knowledge of the functional and performance data of the separation system, as well as an in-depth process understanding of the respective application.

Knowledge about droplet formation and droplet movement in a gas flow is essential to ensure fault-free operation of the mist eliminator. For more than 100 years, we have worked on detection, measurement and definition of droplets. It is therefore not a coincidence that Lechler nozzles and Lechler mist eliminators are now considered integral elements in process engineering.

Each installation requires a specific mist eliminator design and construction. Design, construction and selection of the optimum Lechler mist eliminators are based fully on your requirements, specifications and drawings. That is why we do not offer standard solutions, but customize systems individually for your specific needs.

In order to guarantee accurate operation, materials must be used that are matched to the relevant variables of the installation in question. For this reason, Lechler offers a wide range of different materials – from stock.

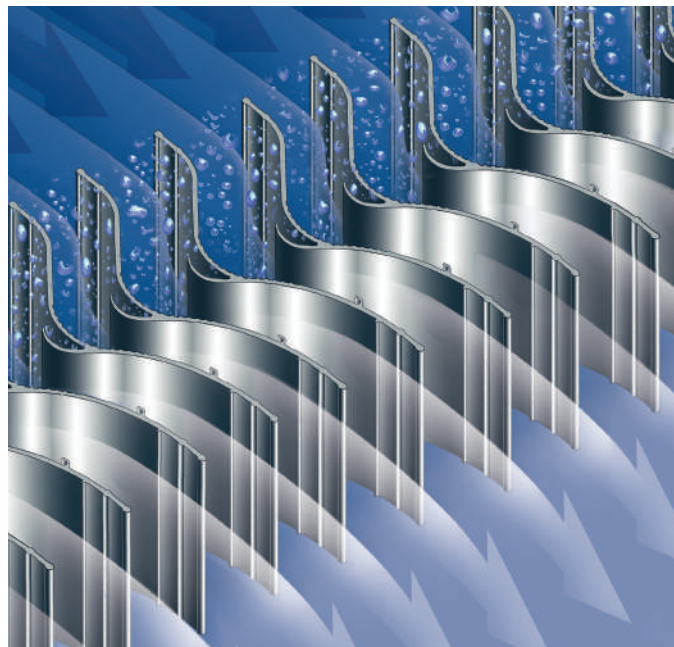

The available materials include:

- Stainless steels in the grades 304 SS, 316L SS, 316Ti SS, 318LN SS, 904L SS, 254SMO SS as well as special alloys such as Hastelloy
- Plastics such as PP, PPTV, PE, PVDF

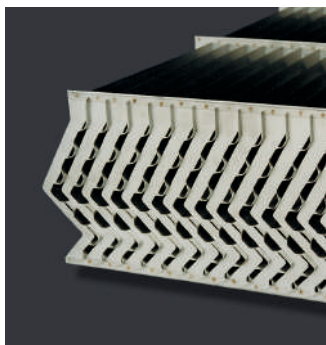

Talk to us

Do you know your process but are not sure which mist eliminator is best suited for your purposes? No problem. Based on your individual requirements, we will choose from a finely graded range of vane profiles with single or multiple deflection.

Lechler, Inc
445 Kautz Rd.
St. Charles, IL 60174
Phone: (800) 777-2926
E-Mail: info@lechlerusa.com

Mist eliminators for vertical gas flow

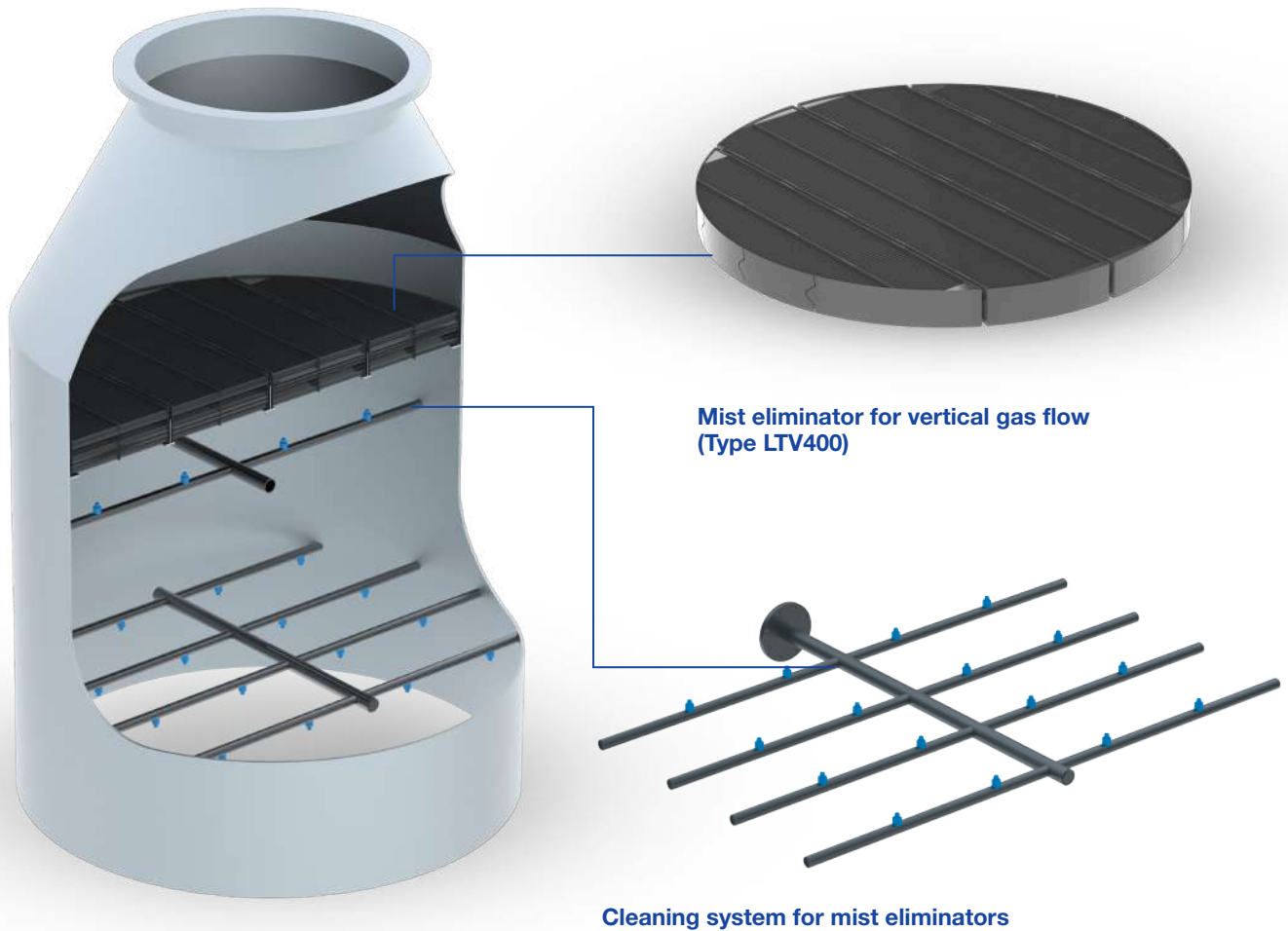

In vane-type eliminators with vertical gas flow, the baffle vanes are arranged horizontally or at a slight horizontal angle. The liquid that is separated at the profile forms a film which drains downwards in the opposite direction to the gas flow. This liquid film interacts with the opposing gas flow. At the bottom end, larger droplets are formed from the liquid film which then fall down.

Reliable operation – even under tough conditions

Lechler mist eliminators are characterized by the optimized-flow design. However, if the gas flows are heavily loaded with dust, deposits can occur under unfavorable conditions which impair the efficiency of the mist eliminators. In this case, an additional cleaning system helps to guarantee availability during continuous operation. An arrangement that performs cyclical washing of the mist eliminators with full-cone nozzles has proven particularly suitable for this. This allows you to increase functional reliability, avoid encrustations and also ensure that your plant operates with optimum efficiency over long periods.

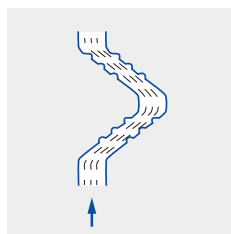
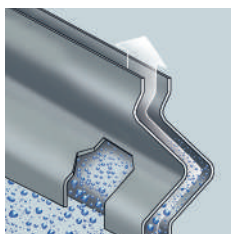

Profile Geometry LTV 271

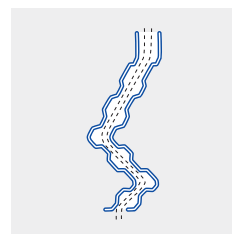

Profile Geometry LTV 300

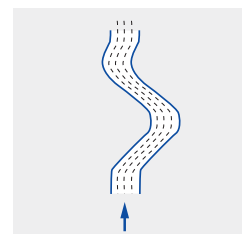

Profile Geometry LTV 400

Mist eliminators

for horizontal gas flow

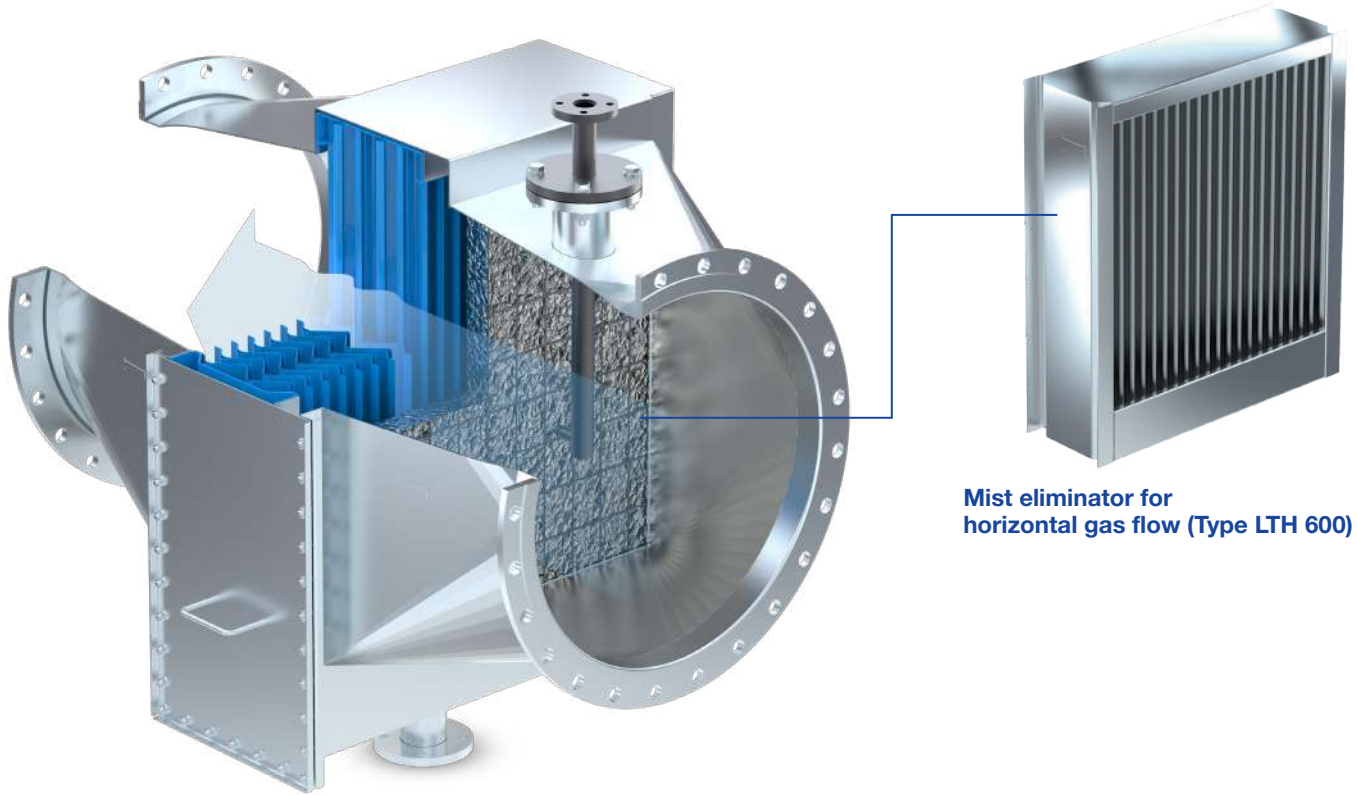

Mist eliminator for horizontal gas flow (Type LTH 600)

Housing with mist eliminator for horizontal gas flow (Type LTH 600) and agglomerator

Vane-type separators for horizontal gas flow use different design features for secondary separation than vertical systems. In vane-type separators for horizontal gas flow, the separation vanes are arranged vertically to the gas flow so that the liquid runs down the baffles due to gravity.

The creation of flow-calmed zones allows the liquid film to specifically drain in these areas without renewed contact with the gas flow. The fact that liquid run-off is assisted by the forces of gravity results in high-performance separation systems. Depending on the separator design, particularly

high flow rates are possible. The flow-optimized shape of the baffle vanes minimizes pressure losses. Based on your individual requirements, it is possible to choose from a finely-graded range of vane profiles with single or multiple deflection.

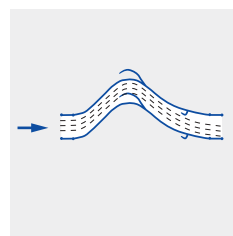

Profile geometry LTH 100

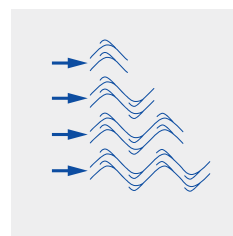

Profile geometry LTH 500

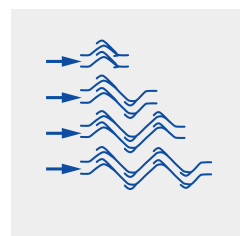

Profile geometry LTH 600

Extreme droplet separation

Finest droplets

In some applications, it is necessary to separate droplets that are significantly smaller than the limit droplet diameter of a vane-type mist eliminator. In these cases, we use fiber packs as agglomerators in combination with vane-type separators.

Large liquid volumes

Optimum pre-separation is necessary if there are liquid surges in the inlet. The Lechler Inlet Device (LID) separates large liquid quantities with maximum efficiency and thus optimizes the flow of the rising gas.

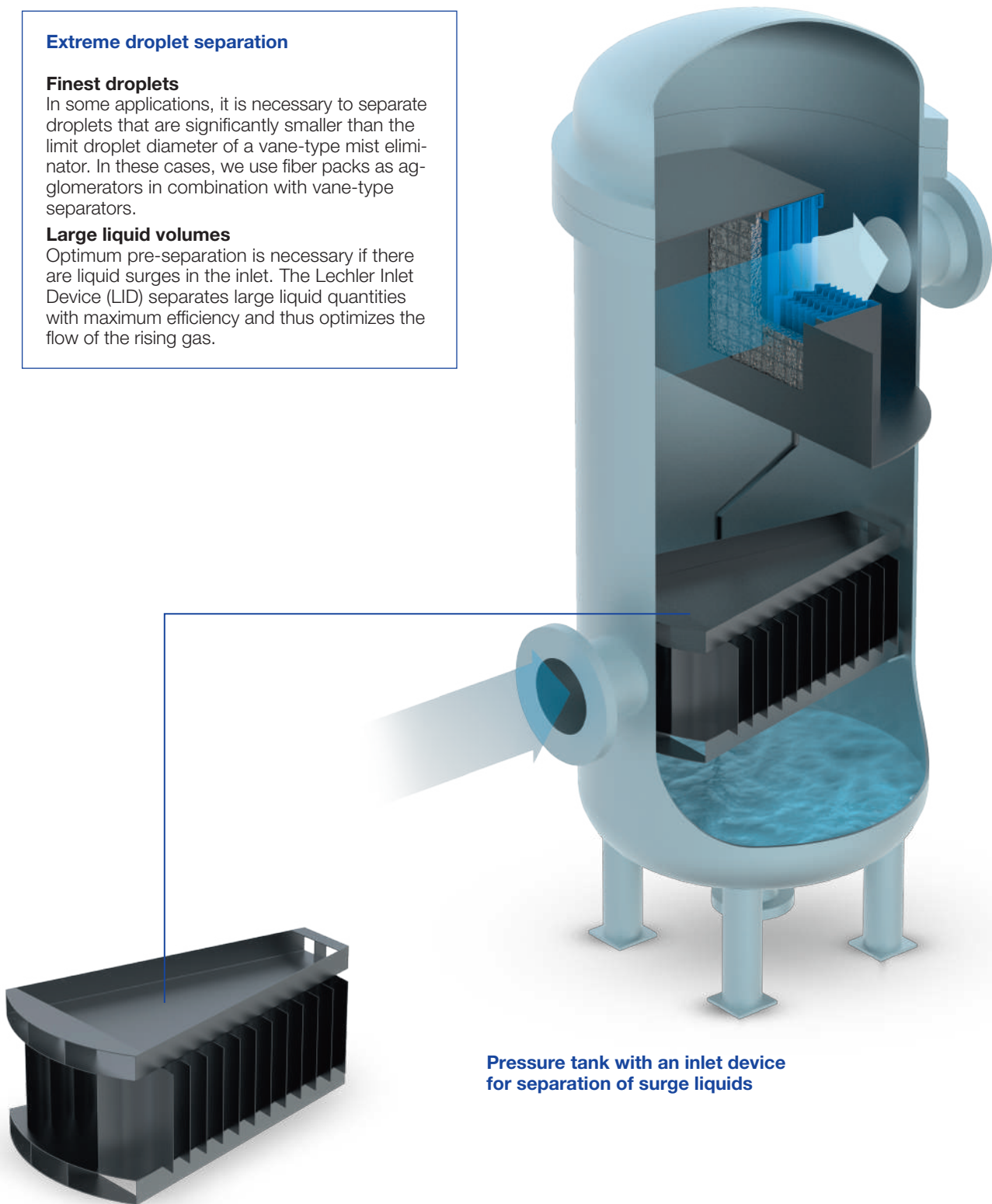

Pressure tank with an inlet device for separation of surge liquids

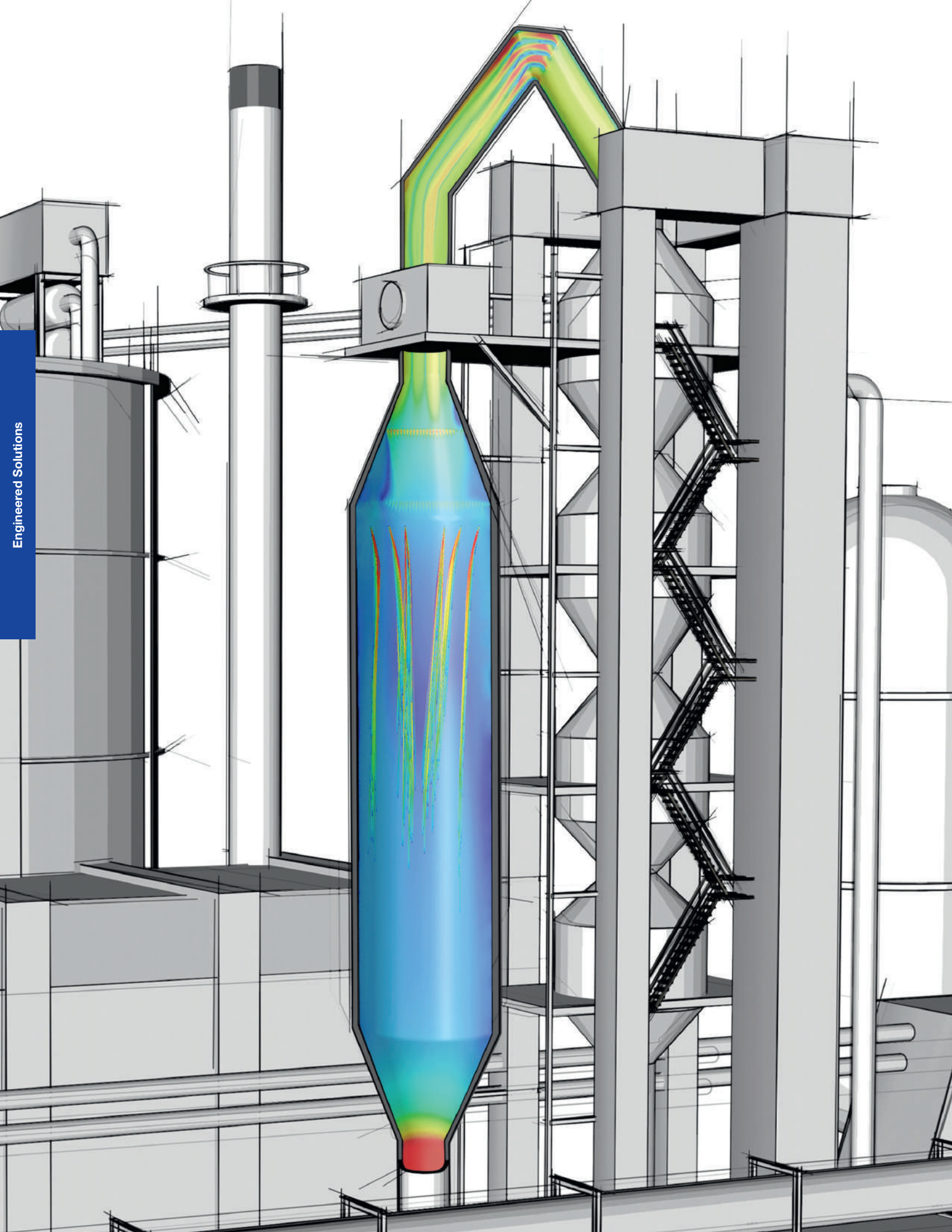

CFD ANALYSIS

Fluid Dynamics simulation as a process optimization tool

No matter what the spray application may be, the goal is always to achieve the maximum effect with the minimum possible use of material, spray media and energy. It is therefore essential to have a detailed understanding of how spray mist is formed and propagated.

This is made possible by computer-assisted simulation of the flow processes of one or more media in static and dynamic environments, taking into account heat and mass transfer and almost every physical effect. These simulations incorporate our know-how from many decades of nozzle development.

In the past, Fluid Dynamics was only an internal tool which helped us to develop nozzles faster and with greater precision. The completion of our high performance cluster with a computing performance of around 8.500 GFlops now allows us to offer our know-how as a service.

We can simulate nozzle applications and processes individually for your environment and requirements. The aim is to make your spray processes working exactly how you want them to.

Our services:

- Simple flow field and pressure loss simulations with one or more gas/liquid in containers, pipes and fittings
- Full spray propagation in almost every environment including heat and mass transfer with the surrounding gases
- Calculation of the internal flow field in nozzles and prediction of the spray pattern as well as water distribution and spray characteristic close to the nozzle

Your advantages:

- Maximum efficiency in
 - media consumption for nozzles and applications
 - geometric dimensions of the whole process
- through optimized
 - nozzle selection
 - nozzle operation (for efficient use of pumps, compressors and fans)
 - spray distribution
 - droplet sizes
 - optimized fluid flow upstream and downstream of the spraying process

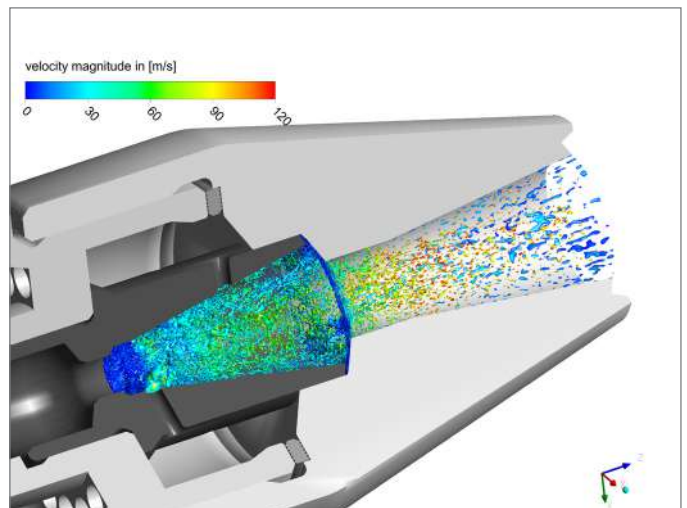
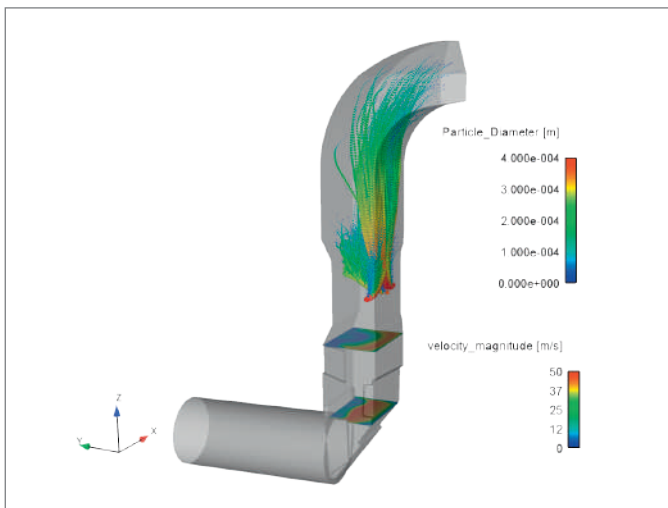



Our unique selling point: Practice-based knowledge

Since it was founded, Lechler has stood out for its development of new technologies. In more than a century we have successfully filed a large number of patents. Starting with the “Centrifugal Sprayer” from 1893 and going up to state-of-the-art technologies of the 21st Century. We will continue this proud tradition into the future, and our new technical center will be key to doing so. After seven years of construction, the Lechler Development and Technology Center was opened in the summer of 2016. Since then it has offered everything nozzle developers dream of on a surface of over 600 m². In addition to extensive measuring facilities, state-of-the-art test benches with a wide range of pump performances are available to measure and investigate sprays, from microfine mist to fuller sprays with varying jetting characteristics.

MEASURING TECHNOLOGY

HOW OUR RESOURCES HELP US ACHIEVE PRECISION

What we are doing before we do it

At Lechler, exact measurements have long been the basis for clearly defined spray characteristics. The data obtained in our laboratories form the foundation for any development and make it easier for our customers to choose nozzles for specific applications. This saves time, lowers costs and provides planning security.

Advanced technology

We have further expanded our research capacities by opening our own Development and Technology Center.

A highlight here is a laser-assisted phase doppler anemometer. As one of the most modern optical measuring procedures, it measures the velocity and the diameter of spherical droplets simultaneously and without contact. Using the data obtained, spectra can be reliably derived for particle size distributions and velocities.

Measurements range from tiny water droplets in the micrometer region to very large droplets of around 8 millimeters. These are performed with a high temporal and spatial resolution.

Individual positions in the spray can be automatically approached and measured with extremely high accuracy – in x, y and z directions.

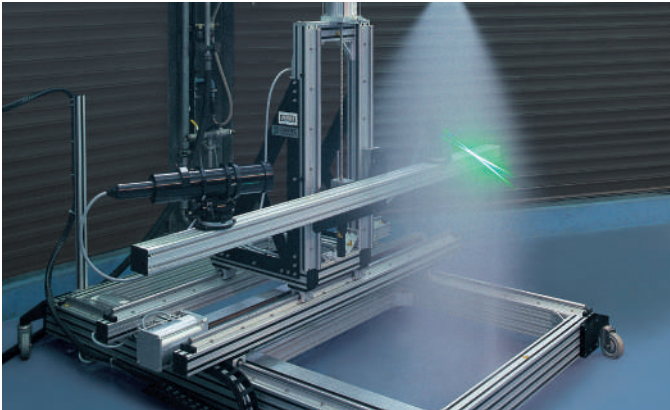

PRECISION NOZZLES: UTMOST ACCURACY AND MAXIMUM AVAILABILITY FOR STANDARD APPLICATIONS

In the chemical industry there are innumerable applications that require the atomization of liquids of all kinds in different ways. The combination of all these parameters leads to thousands of different nozzles. At Lechler, we have them all. In this brochure, we present you with a selection of our most common nozzles used in chemical applications. If for some reason, you cannot find what you are looking for, please contact our experts to help you with finding the right nozzle for your application.

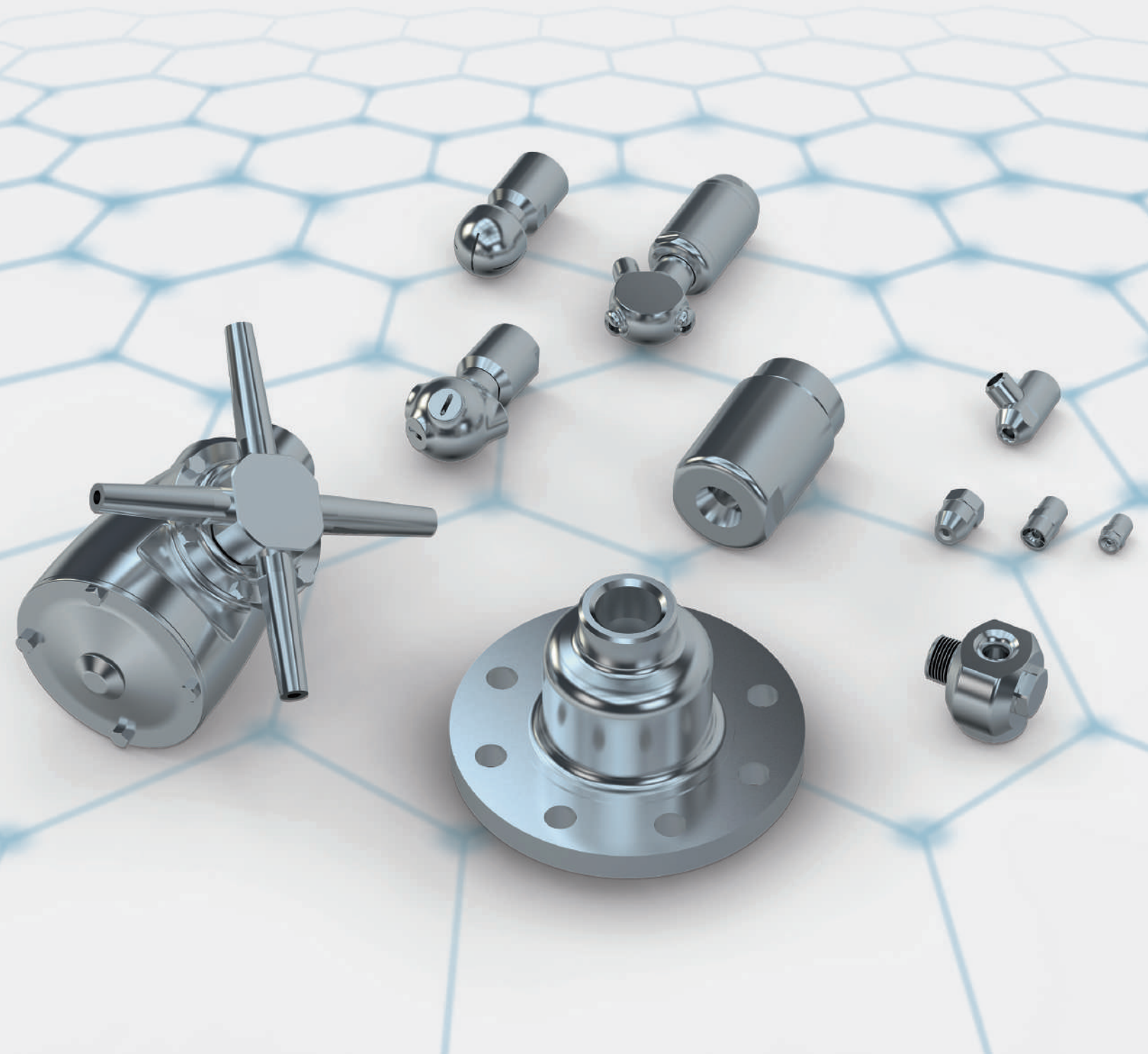

Spillback nozzles

Atomization without compressed air

Lechler spillback nozzles atomize liquids as a fine hollow cone.

This single-fluid nozzle works according to the pressure atomization principle. The water is sent to the nozzle with an almost constant feed pressure, irrespectively of the atomized flow rate.

The amount of liquid injected is adjusted via a control valve in the spillback line, whereby part of the flow is taken from the inlet flow rate and carried back to the tank. The maximum atomized flow rate is achieved with the control valve closed.

Uniform and fine liquid atomization is achieved across the entire control range.

If the volume to be atomized is distributed over cluster heads with up to six small spillback nozzles, this leads to an improvement in the droplet quality compared to a single nozzle.

Thanks to the cluster heads' total spray angle of about 120°, the distribution of the water volume over the entire channel cross-section improves. The number of lances can be reduced in this way. We also recommend this option when upgrading existing gas cooling towers in particular.

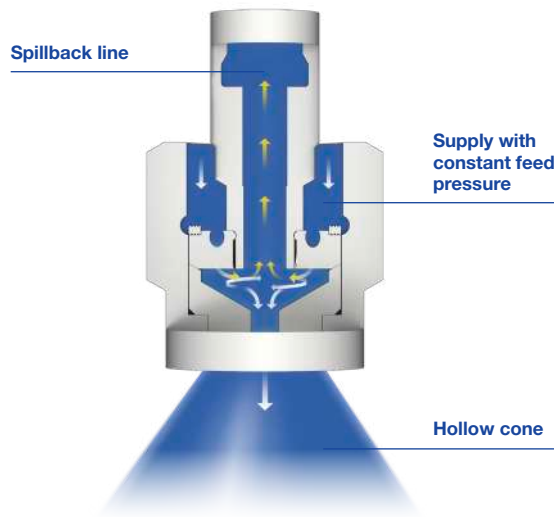

Scheme of the spillback nozzle

Use:
 ■ Gas cooling in medium-sized and large gas cooling towers

Properties



Spray angle of the individual nozzles
 90° as hollow cone



Low operating costs
 as no atomizing air required



Execution
 as single or cluster nozzle lances possible



High turn-down ratio
 10:1 (up to 12:1)



Even and fine liquid atomization
 over the entire control range



Typical pressure range
 of 508 psi, g in the supply line at the nozzle

VarioJet® nozzles

Twin-fluid nozzles with low air consumption despite large outlet angle

Lechler VarioJet® nozzles

atomize according to the principle of internal mixing. With this twin-fluid nozzle, the water is fed in axially via a bore hole.

After arriving at the cone tip, the liquid is split up into a thin liquid film. This thin liquid film is split into finest droplets by the atomizing air in the mixing chamber. The resulting two-phase mixture is then atomized a second time when exiting via several bore holes arranged in a circular pattern.

Thanks to the innovative design of the nozzle, a spray with a large outlet angle is achieved. This is characterized by an even liquid distribution as well as a fine droplet spectrum with a low specific air consumption.

The fineness of the droplet spectrum is decisively influenced by the air/liquid ratio and by the pressure level of the two fluids. As a general rule: the higher the air/liquid ratio and the higher the pressure level of atomizing air and liquid is, the finer the droplet spectrum.

The large free cross-sections in the nozzle keep the risk of clogging and the maintenance effort to a minimum.



Spray pattern of the VarioJet® nozzle

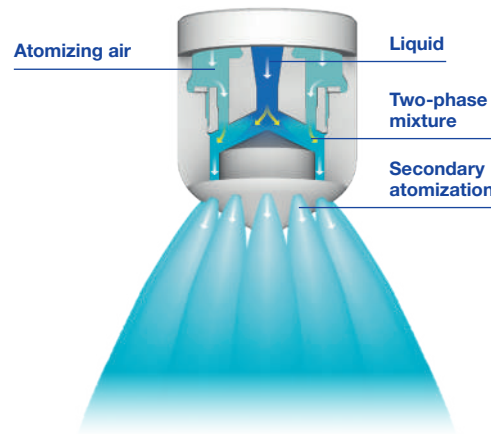

Scheme of the VarioJet® nozzle

Use:

- Gas cooling in gas cooling towers as well as gas-bearing pipes (ducts)

Properties



Large spray angle
60°, 90° for good coverage of the cross-section of the duct



Adjustment of the droplet spectrum
by changing the air/liquid ratio



Clog-resistant
thanks to large free cross-sections without internal fittings



High turn-down ratio
up to 20:1



Low air consumption



Typical pressure range
Liquid 15-130 psi, g
Atomizing air 15-87 psi, g

Laval nozzles

Twin-fluid nozzles for a wide droplet spectrum in special applications

Lechler Laval nozzles

atomize liquids as a fine full cone. These twin-fluid nozzles work according to the supersonic principle.

A dual-phase mixture is created from atomizing air and liquid in the mixing chamber inside the nozzle. The shape of the nozzle causes this mixture to be accelerated to supersonic speed, resulting in an extremely fine atomization of the droplets.

By changing the air/liquid ratio, the droplet size and the droplet spectrum can be adapted within a wide range. The large free cross sections of the nozzle also allow atomization of viscous or solids-laden liquids.

Choosing the right material prevents wear even where abrasive media are present, and enables use at high temperatures.



Spray pattern of the Laval nozzle

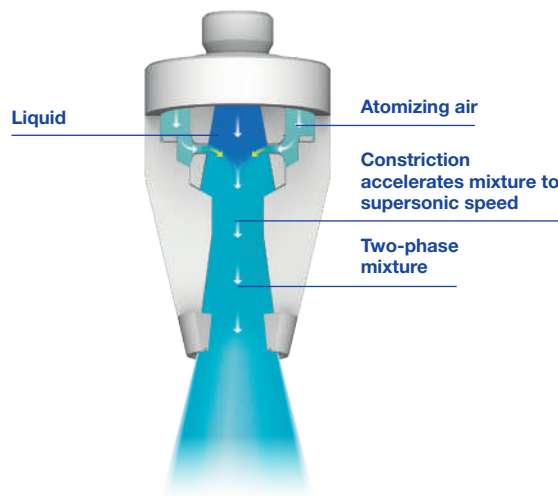

Scheme of the Laval nozzle

Use:

- Gas cooling in gas-bearing pipes (ducts) and medium-sized and small gas cooling towers
- Injection of solids-laden water
- Introduction of lime water in the desulfurisation process
- Injection of aqueous ammonia or urea solution for the DeNO_x process (SNCR/SCR)
- Chemical process engineering (spray dryers etc.)

Properties



Small spray angle
15°, suitable for small cross-sections and horizontal ducts



Adjustment of the droplet spectrum
by changing the air/liquid ratio



Clog-resistant
thanks to large free cross-sections without internal fittings



Very large turn down ratio
of 20:1 (in some cases up to 40:1)



Very fine droplet spectrum



Typical pressure range
Liquid 15-87 psi, g
Atomizing air 15-87 psi, g



Twin-fluid nozzles with internal mixing Series 170 / 180

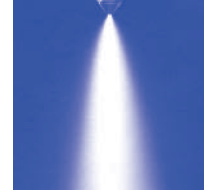

Efficient atomization by mixing liquid and gas.

- Internal mixing principle (Mixing chamber inside the nozzle combines a gas and a liquid to form an intensive dual-phase mixture)
- Extremely fine atomization with good regulating performance
- Large free cross sections
- Lower air consumption than with nozzles that mix externally
- Maintenance-free operation

Applications:

Gas cooling, air humidification, flue gas desulphurisation, spray drying, absorption

Liquid pressure:

14.5 - 72.5 psi

Air pressure:

14.5 - 72.5 psi

Regulating range up to max.:

1 : 30

Spray angle:

approx. 20°

The nozzle's large free cross sections allow maintenance-free operation even when atomizing viscous and abrasive media with a high solid content.

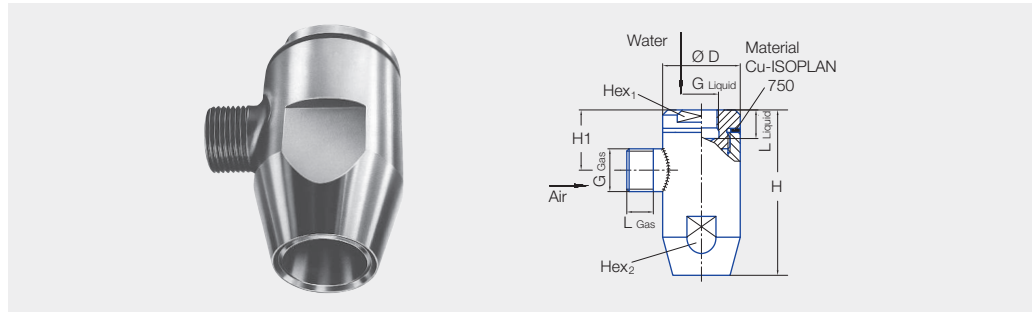

Type	Dimensions (in.)										Weight (lbs.)
	H	H ₁	D	Hex ₁	Hex ₂	G _{Liquid} NPT	G _{Gas} NPT	L _{Liquid}	L _{Gas}		
180.641	1.9	1.1	.98	22	22	1/8	1/8	.38	.40	0.31	
180.721	3.19	1.16	1.50	1-1/4	1-1/4	3/8	1/2	.55	.51	1.19	
170.801	3.19	1.16	1.50	1-1/4	1-1/4	3/8	1/2	.55	.51	1.19	
170.881	3.19	1.16	1.50	1-1/4	1-1/4	3/8	1/2	.55	.51	1.19	
170.961	4.41	1.65	2.05	1-13/16	1-13/16	1/2	3/4	.71	.59	2.81	

Ordering no.			Orifice diameter (in.)		Air pressure (psi)											
Type	Mat. no. 1Y	Connection Male NPT 3/8" 1/2" 3/4"	Air	Water	14.5			29			43.5			Water psi	Water GPM	Air ft ³ /hr
					Water psi	Water GPM	Air ft ³ /hr	Water psi	Water GPM	Air ft ³ /hr	Water psi	Water GPM	Air ft ³ /hr			
180.641	○	BB - -	.12	.17	11.6	.11	706	24.7	.16	1130	36.3	.21	1519	45.0	.24	1942
					13.1	.26	636	27.6	.40	989	46.4	.79	1271	66.7	1.06	1519
					18.9	.66	494	39.2	.92	812	58.0	1.32	1130	84.1	1.85	1307
180.721	○	- BF -	.15	.20	8.7	.13	1519	18.9	.18	2331	31.9	.24	3037	43.5	.29	3849
					11.6	.53	1307	24.7	.79	1942	39.2	1.06	2613	53.7	1.59	3037
					13.1	.92	1130	27.6	1.45	1730	45.0	1.98	2260	60.9	2.38	2790
170.801	○	- BF -	.08	.22	10.2	.26	1413	21.8	.26	2048	31.9	.32	2825	46.4	.32	3708
					13.1	.79	1236	26.1	1.32	1836	37.7	1.85	2543	52.2	2.64	3214
					14.5	1.32	1130	29.0	2.64	1695	43.5	3.70	2225	58.0	5.28	2931
170.881	○	- BF -	.11	.30	8.7	.26	2119	21.8	.32	3355	31.9	.40	4591	45.0	.48	6039
					11.6	1.32	1942	24.7	1.85	3178	36.3	2.64	4167	50.8	3.96	5438
					13.1	2.11	1766	27.6	3.43	2825	43.5	5.02	3708	59.5	7.40	5050
170.961	○	- - BH	.13	.37	8.7	.26	3320	20.3	.32	5474	31.9	.40	7416	43.5	.48	9712
					11.6	1.32	3002	24.7	2.64	4591	37.7	3.96	6321	50.8	5.28	7769
					14.5	3.17	2543	27.6	5.02	4061	43.5	6.87	5368	59.5	10.04	6992

Example Type + Material no. + Conn. = Ordering no.
for ordering: 170.801 + 1Y + BF = 170.801.1Y.BF



Twin-fluid nozzles Series 150



Fine liquid atomization by means of air or vapor.

- Liquid, air or vapor are supplied under pressure
- The air or vapor pressure must always be higher than liquid pressure
- A higher air-/water ratio leads to finer atomization

Applications:

Chemical process engineering, cooling processes, atomizing viscous liquids.

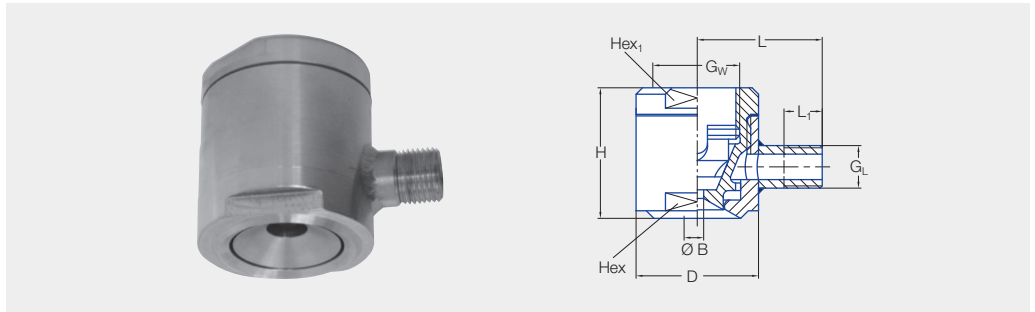

Type	G _w BSPP	G _L BSPP	H [in]	D [in]	L [in]	L ₁ [in]	Hex [in]	Hex ₁ [in]	Weight 316Ti SS
150.005.17 – 150.013.17	G 3/8	G 1/4 A	1.5	1.10	1.28	.39	.94	.94	.31 lbs
150.032.17	G 1	G 3/8 A	2.05	1.89	1.93	.59	1.61	1.61	1.10 lbs
150.050.17 – 150.063.17	G 1 1/4	G 1/2 A	2.95	2.56	2.28	.59	2.17	2.17	2.98 lbs

Spray angle	Ordering no.		Orifice diam. (in.)	Ø B (in.)	Flow Rate (Gallons Per Minute) at Pressure (psi)						Flow Rate (ft ³ /hr) at Air Pressure (psi)			
	Type	Mat. no. 316 SS 17 ¹			5.0	7.5	10.0	14.5	22.0	29.0	14.5	29.0	43.5	58.0
20°-30°	150.005	○	.04	.04	.04	.05	.06	.07	.09	.11	353	530	706	883
	150.007	○	.08	.08	.11	.13	.15	.19	.23	.26	353	530	706	883
	150.009	○	.16	.08	.27	.34	.39	.47	.58	.66	353	530	706	883
	150.010	○	.14	.08	.44	.54	.62	.75	.92	1.06	353	530	706	883
	150.013	○	.24	.08	.88	1.07	1.24	1.50	1.84	2.11	353	530	706	883
	150.032	○	.31	.11	.88	1.07	1.24	1.50	1.84	2.11	1095	1660	2225	2825
	150.050	○	.35	.19	1.76	2.15	2.48	2.99	3.68	4.23	2119	3178	4238	5297
	150.052	○	.35	019	3.46	4.23	4.89	5.88	7.25	8.32	2119	3178	4238	5297
	150.063	○	.59	019	6.91	8.46	9.77	11.77	14.50	16.64	3531	5297	7063	8829

¹We reserve the right to deliver AISI 316 or 316 Ti under the material no. 17.

Example for ordering:	Type	+	Material no.	=	Ordering no.
	150.005	+	17	=	150.005.17



Axial-flow hollow cone nozzles Series 220





Extremely fine, fog-like hollow one spray.

Applications:

Disinfection, humidification and cooling.

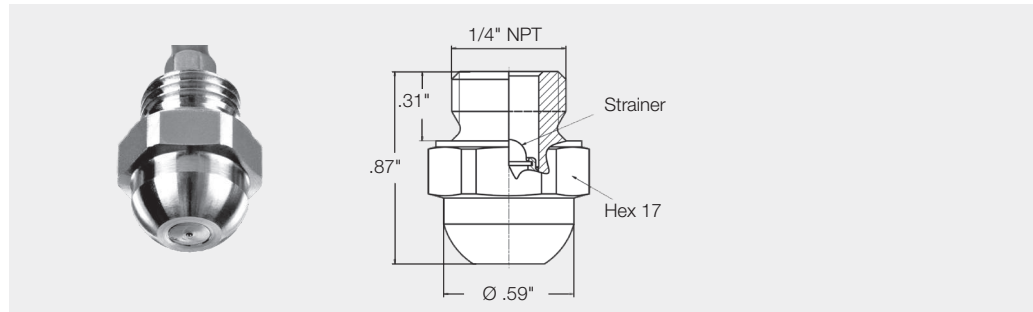
Nozzles of series 220 replace series 212 which are still available on request.



Spray angle	Ordering no.				Orifice diam. (in.)	Free Passage (in.)	Mesh size Strainer (in.)	Flow Rate (Gallons Per Minute)						Spray Diam. D (in.) @ 72 psi  H=4"	Theoretical Spray Width @ 72.5 psi (5 bar) H=100mm	
	Type	Mat. no.		Connection				30 psi	45 psi	5 bar	75 psi	100 psi	150 psi			300 psi
		AISI 430F 11	AISI 316L* 1Y													
60°	220. 004	○	○	BC	.004	.004	.002	-	-	.013	.003	.004	.005	.007	4	100
	220. 014	○	○	BC	.006	.006	.002	-	.004	.019	.005	.006	.007	.010	4	100
	220. 054	○	○	BC	.008	.006	.002	.004	.006	.027	.007	.008	.010	.014	6	140
80°	220. 085	○	○	BC	.010	.010	.004	.007	.008	.040	.011	.012	.015	.021	6	140
	220. 125	○	○	BC	.014	.014	.004	.010	.013	.062	.016	.019	.023	.033	6	140
	220. 145	○	○	BC	.016	.016	.004	.014	.017	.082	.022	.026	.031	.043	6	140
	220. 165	○	○	BC	.018	.018	.004	.017	.021	.103	.027	.032	.039	.054	6	140
	220. 185	○	○	BC	.022	.014	.008	.022	.027	.130	.034	.041	.049	.069	6	140
	220. 205	○	○	BC	.024	.014	.008	.028	.034	.168	.044	.053	.063	.089	6	140
	220. 245	○	○	BC	.028	.020	.008	.044	.053	.261	.069	.082	.097	.138	6	140
220. 285	○	○	BC	.035	.022	.008	.065	.080	.390	.103	.122	.146	.206	6	140	

Example Type + Material no. + Conn. = Ordering no.
for ordering: 220. 004 + 1Y + BC = 220. 004. 1Y. BC

The integrated strainer avoids clogging of the nozzle and increases its service life.

*** Materials**

Mat. no.	Housing	Nozzle insert	Strainer
11	AISI 430F	AISI 430F	AISI 316L
1Y	AISI 316L	AISI 316L	AISI 316L



Axial-flow hollow cone nozzles Series 226





Hollow cone nozzle for assembly with retaining nut. Extremely fine, fog-like hollow cone spray.

Applications:

Disinfection, humidification and cooling.

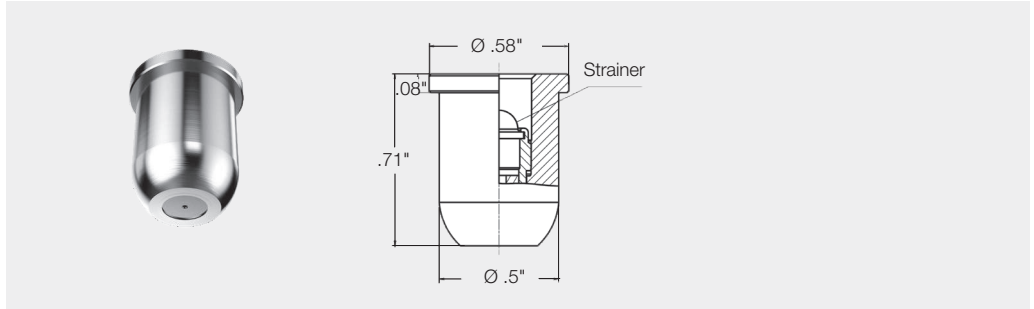
Nozzles of series 220 replace series 212 which are still available on request.



Spray angle	Ordering no.		Orifice diam. (in.)	Free Passage (in.)	Mesh size Strainer (in.)	Flow Rate (Gallons Per Minute)							Spray Diam. D (in.) @ 72 psi  H=4"	Theoretical Spray Width @ 72.5 psi (5 bar) H=100mm
	Type	Material no. AISI 303 ¹⁶				liters per minute		Gallons Per Minute						
						30 psi	45 psi	75 psi	100 psi	150 psi	300 psi			
60°	226. 004	○	.004	.004	.002	-	-	.013	.003	.004	.005	.007	4	100
	226. 014	○	.006	.006	.002	-	.004	.019	.005	.006	.007	.010	4	100
	226. 054	○	.008	.006	.002	.004	.006	.027	.007	.008	.010	.014	6	140
80°	226. 085	○	.010	.010	.004	.007	.008	.040	.011	.012	.015	.021	6	140
	226. 125	○	.014	.014	.004	.010	.013	.062	.016	.019	.023	.033	6	140
	226. 145	○	.016	.016	.004	.014	.017	.082	.022	.026	.031	.043	6	140
	226. 165	○	.018	.018	.004	.017	.021	.103	.027	.032	.039	.054	6	140
	226. 185	○	.022	.014	.008	.022	.027	.130	.034	.041	.049	.069	6	140
	226. 205	○	.024	.014	.008	.028	.034	.168	.044	.053	.063	.089	6	140
	226. 245	○	.028	.020	.008	.044	.053	.261	.069	.082	.097	.138	6	140
226. 285	○	.035	.022	.008	.065	.080	.390	.103	.122	.146	.206	6	140	

Example Type + Material no. = Ordering no.
for ordering: 226. 004 + 16 = 220. 004. 16

The integrated strainer avoids clogging of the nozzle and increases its service life.

*** Materials**

Mat. no.	Housing	Nozzle insert	Strainer
16	AISI 303	AISI 430F	AISI 316L



Axial-flow hollow cone nozzles Series 214 / 216 / 218



Fine, uniform hollow cone spray.

Applications:

Cooling and cleaning of air and gas, dust control, spraying onto filters, spray drying, desuperheating.

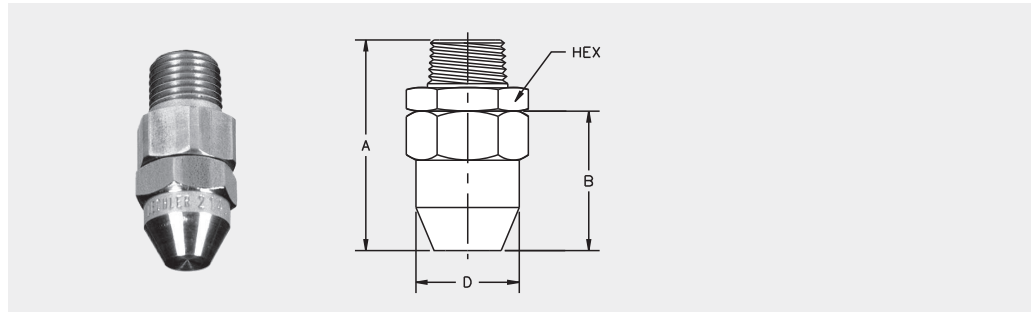

Thread Size Ordering no.	Dimensions (in.)					Approx. Wt. (lb.) Brass
	Hex Male NPT	Size	A	B	D	
214. xxx. YY. BA	1/8	11/16	1.531	.718	.625	.15
214. xxx. YY. BC	1/4	11/16	1.593	.718	.625	.20
216. xxx. YY. BC	1/4	7/8	1.468	1.156	.843	.25
216. xxx. YY. BE	3/8	7/8	1.468	1.156	.843	.25
218. xxx. YY. BG	1/2	1-1/16	2.531	1.406	1.031	.30

Spray angle	Ordering no.						Orifice diam. (in.)	Free Passage (in.)	Flow Rate (Gallons Per Minute)							Spray Diam. D (in.) @ 40 psi H=10"
	Type	Mat. no.		Connection		10 psi			20 psi	liters per minute 2 bar	40 psi	60 psi	80 psi	100 psi		
		316SS 17	Brass 30	1/8"	1/4"										3/8"	
60°	214. 184	○	○	BA BC	-	-	.020	.019	.01	.02	.08	.02	.03	.04	.04	8
80°	214. 245	○	○	BA BC	-	-	.039	.019	.02	.04	.16	.05	.06	.07	.08	18
	214. 305	○	○	BA BC	-	-	.071	.019	.05	.07	.32	.10	.12	.14	.16	18
60°	216. 324	○	○	-	BC BE	-	.039	.039	.06	.09	.40	.12	.15	.18	.20	8
	216. 364	○	○	-	BC BE	-	.055	.055	.10	.14	.63	.20	.24	.28	.31	8
	216. 404	○	○	-	BC BE	-	.079	.078	.16	.22	1.0	.31	.38	.44	.49	8
90°	216. 496	○	○	-	BC BE	-	.118	.078	.26	.37	1.7	.53	.65	.75	.83	20
	216. 566	○	○	-	BC BE	-	.158	.078	.39	.55	2.5	.78	.95	1.1	1.2	20
	216. 646	○	○	-	BC BE	-	.138	.078	.62	.88	4.0	1.2	1.5	1.8	2.0	20
	216. 686	○	○	-	BC BE	-	.158	.078	.78	1.1	5.0	1.6	1.9	2.2	2.5	20
	216. 726	○	○	-	BC BE	-	.197	.078	.98	1.4	6.3	2.0	2.4	2.8	3.1	20
	216. 776	○	○	-	BC BE	-	.236	.078	1.3	1.9	8.5	2.6	3.2	3.7	4.2	20
	218. 646	○	○	-	-	BG	.197	.078	.62	.88	4.0	1.2	1.5	1.9	2.0	20
	218. 666	○	○	-	-	BG	.217	.078	.70	.99	4.5	1.4	1.7	2.0	2.2	20
	218. 706	○	○	-	-	BG	.256	.078	.87	1.2	5.6	1.7	2.1	2.5	2.8	20
	218. 766	○	○	-	-	BG	.197	.078	1.2	1.8	8.0	2.5	3.0	3.5	3.9	20
218. 826	○	○	-	-	BG	.256	.078	1.7	2.5	11.2	3.5	4.3	4.9	5.5	20	
218. 846	○	○	-	-	BG	.296	.078	1.9	2.7	12.5	3.9	4.8	5.5	6.1	20	
218. 886	○	○	-	-	BG	.355	.094	2.5	3.5	16.0	5.0	6.1	7.0	7.9	20	

Example Type + Material no. + Conn. = Ordering no.
for ordering: 216. 496 + 17 + BC = 216. 496. 17. BC

This product line is also available in larger capacities up to 5 gpm @ 40 psi. Please contact your local representative or Lechler if you require a larger size.



Eccentric hollow cone nozzles Series 373 »Ramp Bottom«



Fine, uniform hollow cone spray, also at low pressures.

Applications:

cooling and cleaning of gas,
water re-cooling, dust control,
chemical process engineering.

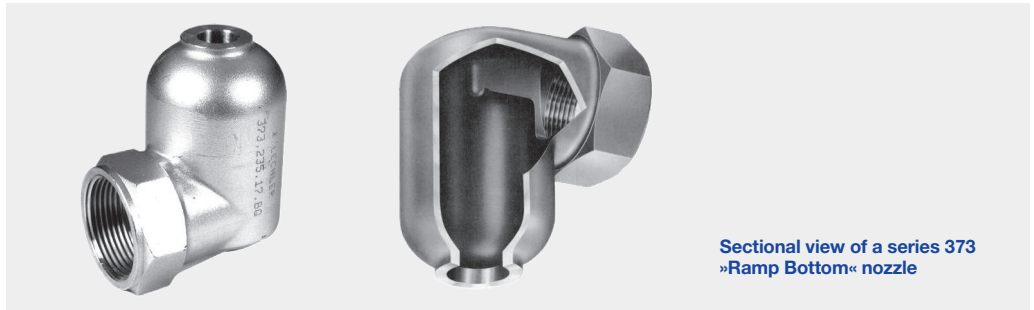

Sectional view of a series 373 »Ramp Bottom« nozzle

Inlet (Female NPT)	Dimensions (in.)					Wt.(lb.)
	A	B (Hex)	C	D	E	
3/4	2.2	1.3	1.9	1.5	.19	.4
1	2.6	1.6	2.1	1.8	.25	.6
1-1/4	3.0	1.9	2.6	2.0	.31	1.2
1-1/2	3.8	2.2	3.2	2.6	.31	2.0
2	4.3	2.8	3.7	2.8	.50	2.7
2-1/2	5.3	3.1	5.5	3.4	.81	4.5
3 (narrow)	6.7	4.0	6.8	4.3	1.1	11
3 (standard)	6.0	4.0	4.6	4.5	1.1	10
4 (narrow)	8.8	5.0	9.5	5.3	1.4	35
4 (standard)	8.8	5.0	7.5	5.4	1.4	32

Narrow angle nozzles

Type	Ordering no.		Orifice diam. (in.)	Flow Rate (Gallons Per Minute)									Spray Angle in degrees at		
	Mat. no.	Connection		3 psi	5 psi	7 psi	10 psi	15 psi	20 psi	liters per minute			3 psi	7 psi	15 psi
										2 bar	40 psi	60 psi			
373. 513	316 SS	MB -	1.45	53	68	80	94	114	132	601	183	220	45	48	48
373. 553	17	MB -	1.62	67	86	100	119	144	165	752	230	278	42	48	50
373. 583		MB -	1.81	80	103	120	143	173	198	902	277	335	44	48	48
373. 603		MB -	2.03	94	120	140	166	202	232	1057	320	388	42	48	50
373. 613		MB -	2.09	101	128	150	178	215	246	1121	341	413	39	48	50
373. 613		- MF	2.03	101	128	150	178	215	246	1121	341	413	42	47	48
373. 623		- MF	2.21	117	150	175	207	250	285	1299	395	480	41	47	52
373. 633		- MF	2.50	135	171	200	236	285	328	1495	450	545	41	47	52
373. 643		- MF	2.68	152	194	225	266	322	368	1677	508	615	41	47	51
373. 653		- MF	2.87	165	208	245	287	348	399	1899	550	662	41	47	50
373. 673		- MF	3.17	201	255	300	353	428	490	2234	680	820	41	47	49

Precision Spray Nozzles



Eccentric hollow cone nozzles

Series 373 »Ramp Bottom«

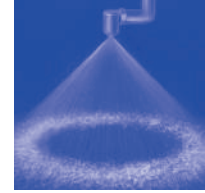

Wider angle nozzles

Type	Ordering no.									Orifice diam. (in.)	Flow Rate (Gallons Per Minute)						Spray Angle in degrees at					
	Mat.no.	Connection									3 psi	5 psi	7 psi	10 psi	15 psi	20 psi	liters per minute			5 psi	15 psi	40 psi
		Female NPT	3/4"	1"	1 1/4"	1 1/2"	2"	2 1/2"	3"								4"	2 bar	40 psi			
372. 975	○	BL	-	-	-	-	-	-	-	.28	2.2	2.9	3.4	4.0	4.9	5.7	26	8.1	9.9	56	70	74
373. 015	○	BL	-	-	-	-	-	-	-	.32	2.8	3.6	4.3	5.1	6.3	7.2	33	10.2	12.5	66	74	75
373. 045	○	BL	-	-	-	-	-	-	-	.35	3.5	4.5	5.3	6.4	7.8	9.0	41	12.7	15.6	72	80	78
373. 084	○	-	BN	-	-	-	-	-	-	.37	4.2	5.5	6.5	7.8	9.5	11.0	50	15.5	19.0	57	60	62
373. 115	○	-	BN	-	-	-	-	-	-	.45	5.1	6.6	7.8	9.3	11.4	13.2	60	18.6	23	64	72	71
373. 145	○	-	BN	-	-	-	-	-	-	.48	6.2	8.0	9.5	11.3	13.9	16.0	73	23	28	72	82	78
373. 175	○	-	BN	-	-	-	-	-	-	.51	7.2	9.3	11.0	13.2	16.2	18.6	85	26	32	80	84	82
373. 205	○	-	-	BQ	-	-	-	-	-	.59	8.6	11.1	13.1	15.7	19.2	22	101	31	38	70	78	78
373. 235	○	-	-	BQ	-	-	-	-	-	.64	10.3	13.3	15.7	18.8	23	27	121	38	46	66	76	75
373. 255	○	-	-	BQ	-	-	-	-	-	.68	11.0	14.3	16.9	20	25	29	130	40	49	66	76	75
373. 285	○	-	-	BQ	-	-	-	-	-	.81	14.2	18.3	22	26	32	37	167	52	63	80	85	84
373. 325	○	-	-	-	BS	-	-	-	-	.80	16.7	22	25	30	37	43	196	61	74	80	85	85
373. 345	○	-	-	-	BS	-	-	-	-	.87	19.0	25	29	35	43	49	224	70	85	82	85	84
373. 365	○	-	-	-	BS	-	-	-	-	.93	21	27	32	38	47	54	248	77	94	74	78	77
373. 384	○	-	-	-	-	BW	-	-	-	.87	24	31	37	44	54	62	282	88	107	65	69	68
373. 415	○	-	-	-	-	BW	-	-	-	1.01	29	37	44	52	64	74	337	105	128	74	78	77
373. 445	○	-	-	-	-	BW	-	-	-	1.14	35	45	53	63	77	89	406	126	154	77	80	80
373. 465	○	-	-	-	-	BW	-	-	-	1.21	39	51	60	72	88	101	461	143	175	82	94	90
373. 505	○	-	-	-	-	-	BZ	-	-	1.28	46	60	71	85	104	120	547	170	208	75	78	77
373. 515	○	-	-	-	-	-	BZ	-	-	1.37	51	66	78	93	114	132	601	186	228	80	84	82
373. 535	○	-	-	-	-	-	BZ	-	-	1.53	58	75	89	106	130	150	683	212	260	80	84	82
373. 555	○	-	-	-	-	-	BZ	-	-	1.62	64	83	98	117	144	166	756	235	287	80	84	82
373. 514	○	-	-	-	-	-	-	MB	-	1.45	50	65	77	92	112	129	590	183	224	56	61	62
373. 554	○	-	-	-	-	-	-	MB	-	1.62	63	81	96	115	141	163	741	230	282	62	66	68
373. 584	○	-	-	-	-	-	-	MB	-	1.81	77	99	117	140	171	198	902	280	343	62	66	68
373. 605	○	-	-	-	-	-	-	MB	-	2.03	90	116	137	164	201	232	1057	328	402	68	72	77
373. 615	○	-	-	-	-	-	-	MB	-	2.09	95	123	146	174	213	246	1121	348	426	70	76	77
373. 614	○	-	-	-	-	-	-	-	MF	2.03	95	123	146	174	213	246	1121	348	426	64	67	69
373. 625	○	-	-	-	-	-	-	-	MF	2.21	110	143	169	202	247	285	1299	403	494	71	74	78
373. 635	○	-	-	-	-	-	-	-	MF	2.50	127	164	194	232	284	328	1495	464	568	76	80	82
373. 645	○	-	-	-	-	-	-	-	MF	2.68	143	184	218	260	319	368	1677	520	637	78	82	84
373. 655	○	-	-	-	-	-	-	-	MF	2.87	155	200	236	282	346	399	1819	564	691	80	83	87
373. 675	○	-	-	-	-	-	-	-	MF	3.17	190	245	290	347	424	490	2234	693	849	82	85	89

Example Type + Material no. + Conn. = Ordering no.
 for ordering: 373. 325 + 17 + BS = 373. 325. 17. BS



Axial-flow full cone nozzles Series 490 / 491



Non-clogging nozzle design with a very stable spray angle, particularly even liquid distribution and large free cross sections.

Applications:

Cleaning and washing processes, surface spraying, Container cleaning, foam precipitation, degassing of liquids.

Series 490/491 represents a new generation within the axial-flow full cone nozzles product group. These nozzles were developed using state-of-the-art design and simulation methods (CFD).

Nozzles of series 490/491 replace series 460/461 which are still available on request.

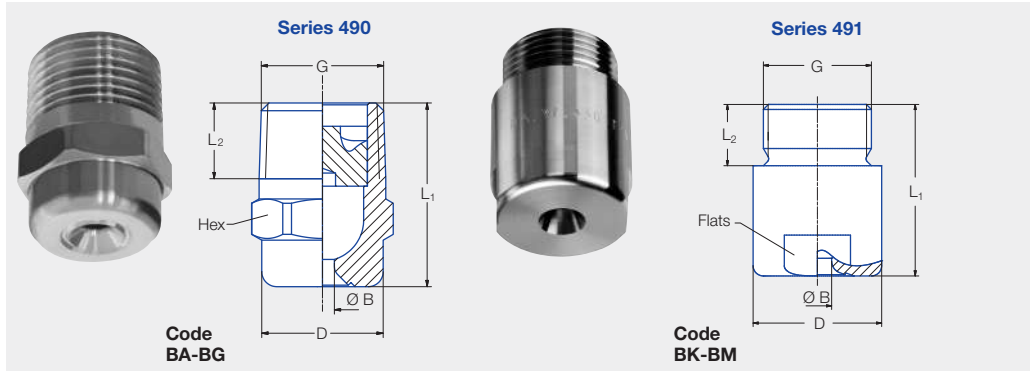

Conn.	Dimensions (in.)					
	G Male NPT	L ₁	L ₂	D	Hex	Weight Brass
BA	1/8	0.71	0.26	0.39	7/16	.03
BC	1/4	0.87	0.39	0.51	9/16	.04
BE	3/8	0.96	0.39	0.63	11/16	.07
BE	3/8	1.18	0.39	0.63	11/16	.11
BG	1/2	1.28	0.51	0.83	14/16	.13
BG	1/2	1.71	0.51	0.83	14/16	.19
BK	3/4	1.65	0.59	1.26	1-1/16	.42
BK	3/4	1.97	0.59	1.26	1-1/16	.44
BM	1	2.20	0.67	1.57	1-7/16	.77

Subject to technical modification.

In a critical installation situation, please ask for the exact dimensions.

Spray angle	Ordering no.										Orifice diam. (in.)	Free Passage (in.)	Flow Rate (Gallons Per Minute)								Spray Diam. D (in.) @ 30 psi		
	Type	Mat. no.		Connection									10 psi	20 psi	2 bar	30 psi	40 psi	60 psi	80 psi	100 psi	150 psi	H=8"	H=20"
		316 L 1Y	Brass 30	Male NPT																			
				1/8"	1/4"	3/8"	1/2"	3/4"	1"														
45°	490.403	○	○	BA	-	-	-	-	-	-	.049	.049	.17	.23	1.00	0.27	.30	.35	.40	.43	.51	6	16
	490.523	○	○	BA	-	-	-	-	-	-	.067	.067	.35	.46	2.00	0.54	.60	.71	.79	.87	1.02	6	16
	490.603	○	○	-	BC	BE	-	-	-	-	.079	.079	.54	.72	3.15	0.84	.95	1.11	1.25	1.37	1.61	6	16
	490.643	-	○	-	-	BE	-	-	-	-	.096	.098	.69	.91	4.00	1.07	1.20	1.41	1.59	1.73	2.04	6	16
	490.683	-	○	-	-	BE	-	-	-	-	.100	.100	.86	1.14	5.00	1.34	1.50	1.77	1.98	2.17	2.55	6	16
	490.703	-	○	-	-	BE	-	-	-	-	.104	.104	.97	1.27	5.60	1.50	1.68	1.98	2.22	2.43	2.85	6	16
	490.723	○	○	-	-	BE	-	-	-	-	.112	.112	1.09	1.43	6.30	1.69	1.89	2.23	2.50	2.73	3.21	6	16
	490.783	-	○	-	-	-	BG	-	-	-	.136	.136	1.55	2.05	9.00	2.41	2.70	3.18	3.57	3.90	4.58	6	16
	490.843	-	○	-	-	-	BG	-	-	-	.150	.150	2.16	2.85	12.50	3.35	3.76	4.42	4.96	5.42	6.37	6	16
60°	490.404	○	○	BA	-	-	-	-	-	.045	.045	.17	0.23	1.00	.27	.30	.35	.40	.43	0.51	9	22	
	490.444	○	-	BA	-	-	-	-	-	.049	.049	.22	0.29	1.25	.33	.38	.44	.49	.54	0.64	9	22	
	490.484	○	○	BA	-	-	-	-	-	.057	.057	.28	0.36	1.60	.43	.48	.57	.63	.69	0.82	9	22	
	490.524	○	○	BA	-	-	-	-	-	.063	.063	.35	0.46	2.00	.54	.60	.71	.79	.87	1.02	9	22	
	490.564	○	○	BA	-	-	-	-	-	.071	.071	.43	0.57	2.50	.67	.75	.88	.99	1.08	1.27	9	22	
	490.604	○	○	BA	BC	BE	-	-	-	.081	.081	.54	0.72	3.15	.84	.95	1.11	1.25	1.37	1.61	9	22	
	490.644	○	○	-	BC	BE	-	-	-	.091	.091	.69	0.91	4.00	1.07	1.20	1.41	1.59	1.73	2.04	9	22	
	490.684	○	○	-	BC	BE	-	-	-	.102	.102	.86	1.14	5.00	1.34	1.50	1.77	1.98	2.17	2.55	9	22	
	490.724	○	○	-	BC	BE	-	-	-	.112	.110	1.09	1.43	6.30	1.69	1.89	2.23	2.50	2.73	3.21	9	22	
	490.764	○	○	-	-	BE	-	-	-	.128	.128	1.38	1.82	8.00	2.14	2.40	2.83	3.17	3.47	4.08	9	22	
	490.804	○	○	-	-	BE	-	-	-	.146	.146	1.72	2.28	10.00	2.68	3.00	3.53	3.97	4.34	5.10	9	22	
	490.844	○	○	-	-	-	BG	-	-	.159	.159	2.16	2.85	12.50	3.35	3.76	4.42	4.96	5.42	6.37	9	22	
	490.884	○	○	-	-	-	BG	-	-	.183	.183	2.76	3.64	16.00	4.28	4.81	5.65	6.34	6.94	8.16	9	22	
	490.924	○	○	-	-	-	-	BK	-	.205	.205	3.45	4.56	20.00	5.36	6.01	7.07	7.93	8.67	10.20	9	22	
	490.964	○	○	-	-	-	-	BK	-	.228	.228	4.31	5.69	25.00	6.70	7.51	8.83	9.91	10.84	12.74	9	22	
491.044	○	○	-	-	-	-	-	BM	.285	.285	6.90	9.11	40.00	10.71	12.02	14.14	15.86	17.34	20.39	9	22		
491.084	○	○	-	-	-	-	-	BM	.321	.321	8.63	11.38	50.00	13.39	15.02	17.67	19.82	21.67	25.49	9	22		

Conversion formula for the above series: $\dot{V}_2 = \dot{V}_1 * \left(\frac{P_2}{P_1}\right)^{0.4}$

Continued on next page.



Axial-flow full cone nozzles

Series 490 / 491



Spray angle	Ordering no.									Orifice diam. (in.)	Free Passage (in.)	Flow Rate (Gallons Per Minute)										Spray Diam. D (in.) @ 30 psi	
	Type	Mat. no.		Connection								10 psi	20 psi	liters per minute 2 bar	30 psi	40 psi	60 psi	80 psi	100 psi	150 psi	H=8"	H=20"	
		316 L 1Y	Brass 30	Male NPT																			
				1/8"	1/4"	3/8"	1/2"	3/4"	1"														
90°	490.406	○	○	BA	-	-	-	-	-	.047	.047	.17	.23	1.00	.27	.30	.35	.40	.43	.51	15	34	
	490.446	-	○	BA	-	-	-	-	-	.051	.051	.22	.29	1.25	.33	.38	.44	.49	.54	.64	15	34	
	490.486	○	○	BA	-	-	-	-	-	.057	.057	0.28	.36	1.60	.43	.48	.57	.63	.69	.82	15	34	
	490.526	○	○	BA	-	-	-	-	-	.067	.067	.35	.46	2.00	.54	.60	.71	.79	.87	1.02	15	34	
	490.566	○	○	BA	-	-	-	-	-	.075	.075	.43	.57	2.50	.67	.75	.88	.99	1.08	1.27	15	34	
	490.606	○	○	BA	-	BE	-	-	-	.081	.081	.54	.72	3.15	.84	.95	1.11	1.25	1.37	1.61	15	34	
	490.646	○	○	-	BC	BE	-	-	-	.094	.094	.69	.91	4.00	1.07	1.20	1.41	1.59	1.73	2.04	15	38	
	490.686	○	○	-	BC	BE	-	-	-	.106	.106	.86	1.14	5.00	1.34	1.50	1.77	1.98	2.17	2.55	15	38	
	490.726	○	○	-	BC	BE	-	-	-	.126	.110	1.09	1.43	6.30	1.69	1.89	2.23	2.50	2.73	3.21	15	38	
	490.746	○	○	-	-	BE	-	-	-	.124	.124	1.23	1.62	7.10	1.90	2.13	2.51	2.82	3.08	3.62	15	38	
	490.766	○	○	-	-	BE	-	-	-	.134	.134	1.38	1.82	8.00	2.14	2.40	2.83	3.17	3.47	4.08	15	38	
	490.806	○	○	-	-	BE	-	-	-	.154	.154	1.72	2.28	10.00	2.68	3.00	3.53	3.97	4.34	5.10	15	38	
	490.846	○	○	-	-	BE	-	-	-	.183	.157	2.16	2.85	12.50	3.35	3.76	4.42	4.96	5.42	6.37	15	38	
	490.886	○	○	-	-	-	BG	-	-	.215	.177	2.76	3.64	16.00	4.28	4.81	5.65	6.34	6.94	8.16	15	38	
	490.926	○	○	-	-	-	BG	-	-	.232	.177	3.45	4.56	20.00	5.36	6.01	7.07	7.93	8.67	10.20	15	38	
	490.966	○	○	-	-	-	BG	BK	-	.258	.191	4.31	5.69	25.00	6.70	7.51	8.83	9.91	10.84	12.74	15	38	
	491.006	○	○	-	-	-	BG	BK	-	.297	.285	5.44	7.17	31.50	8.44	9.47	11.13	12.49	13.66	16.06	15	38	
	491.046	○	○	-	-	-	-	BK	-	.339	.260	6.90	9.11	40.00	10.71	12.02	14.14	15.86	17.34	20.39	15	38	
491.086	○	○	-	-	-	-	BK	BM	.372	.285	8.63	11.38	50.00	13.39	15.02	17.67	19.82	21.67	25.49	15	38		
491.126	○	○	-	-	-	-	-	BM	.409	.315	10.87	14.35	63.00	16.87	18.93	22.26	24.98	27.31	32.12	15	38		
491.146	○	-	-	-	-	-	-	BM	.433	.295	12.25	16.17	71.00	19.01	21.33	25.09	28.15	30.78	36.20	15	38		
120°	490.368	○	○	BA	-	-	-	-	-	.033	.026	.11	.14	.63	.17	.19	.22	.25	.27	.32	27	48	
	490.408	○	○	BA	-	-	-	-	-	.047	.047	.17	.23	1.00	.27	.30	.35	.40	.43	.51	27	48	
	490.448	○	○	BA	-	-	-	-	-	.051	.051	.22	.29	1.25	.33	.38	.44	.49	.54	.64	27	48	
	490.488	○	○	BA	-	-	-	-	-	.057	.057	.28	0.36	1.60	.43	.48	.57	.63	.69	.82	27	48	
	490.528	○	○	BA	-	-	-	-	-	.067	.067	.35	.46	2.00	.54	.60	.71	.79	.87	1.02	27	48	
	490.568	○	○	BA	-	-	-	-	-	.075	.075	.43	.57	2.50	.67	.75	.88	.99	1.08	1.27	27	48	
	490.608	○	○	-	-	-	-	-	-	.083	.081	.54	.72	3.15	.84	.95	1.11	1.25	1.37	1.61	27	48	
	490.648	○	○	-	BC	BE	-	-	-	.094	.094	.69	.91	4.00	1.07	1.20	1.41	1.59	1.73	2.04	27	52	
	490.688	○	○	-	BC	BE	-	-	-	.108	.108	.86	1.14	5.00	1.34	1.50	1.77	1.98	2.17	2.55	27	52	
	490.728	○	○	-	BC	BE	-	-	-	.126	.110	1.09	1.43	6.30	1.69	1.89	2.23	2.50	2.73	3.21	27	52	
	490.748	○	○	-	-	BE	-	-	-	.126	.126	1.23	1.62	7.10	1.90	2.13	2.51	2.82	3.08	3.62	27	52	
	490.768	○	○	-	-	BE	-	-	-	.136	.136	1.38	1.94	8.00	2.14	2.40	2.83	3.17	3.47	4.08	27	52	
	490.808	○	○	-	-	BE	-	-	-	.154	.154	1.72	2.28	10.00	2.68	3.00	3.53	3.97	4.34	5.10	27	52	
	490.848	○	○	-	-	BE	-	-	-	.185	.157	2.16	2.85	12.50	3.35	3.76	4.42	4.96	5.42	6.37	27	52	
	490.888	○	○	-	-	-	BG	-	-	.201	.177	2.76	3.64	16.00	4.28	4.81	5.65	6.34	6.94	8.16	27	52	
	490.928	○	○	-	-	-	BG	-	-	.228	.187	3.45	4.56	20.00	5.36	6.01	7.07	7.93	8.67	10.20	27	52	
	490.968	○	○	-	-	-	BG	BK	-	.262	.191	4.31	5.69	25.00	6.70	7.51	8.83	9.91	10.84	12.74	27	52	
	491.048	○	○	-	-	-	-	BK	BK	.362	.230	6.90	9.11	40.00	10.71	12.02	14.14	15.86	17.34	20.39	27	52	
491.128	○	○	-	-	-	-	-	BM	.425	.305	10.87	14.35	63.00	16.87	18.93	22.26	24.98	27.31	32.12	27	52		
491.148	○	-	-	-	-	-	-	BM	.449	.301	12.25	16.17	71.00	19.01	21.33	25.09	28.15	30.78	36.20	27	52		

Example Type + Material no. + Conn. = Ordering no.
for ordering: 490.368 + 1Y + BA = 490.368.1Y.BA



Axial-flow full cone nozzles Series 485



One-piece design generates large droplets and even distribution at a wide range of operating pressures.

Applications:

High volume surface spraying, cooling and quenching, fire protection, chemical processing and scrubbers.

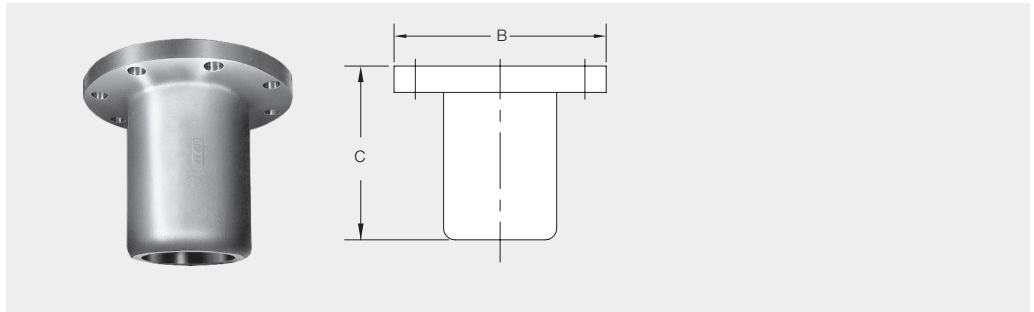

Nozzle Inlet Flange Conn. (in.)	Ordering no.	Orifice diam.* (in.)	Flow Rate (Gallons Per Minute)									Spray Angle in degrees at			Dimensions (in.)		Free Passage (in.)	Approx. Wgt. (lb.)		
			1 psi	2 psi	5 psi	7 psi	10 psi	15 psi	20 psi	liters per minute	2 psi	40 psi	60 psi	3 psi	7 psi	15 psi			B	C
											bar									
4	485. 646. 17. 04	2.25	90	125	191	222	260	318	360	1581	498	605	77	80	82	9.00	6.13	1.19	19	
	485. 656. 17. 04	2.50	105	144	220	257	302	365	420	1844	578	700	86	90	91					
	485. 666. 17. 04	2.75	125	170	262	310	365	440	505	2218	702	860	88	92	94					
	485. 676. 17. 04	3.00	135	188	290	342	404	485	562	2468	784	950	91	95	97					
5	485. 676. 17. 05	2.75	135	188	290	342	404	485	562	2468	784	950	82	92	92	10.00	8.38	.69	42	
	485. 686. 17. 05	2.84	145	201	310	365	430	521	602	2644	827	1005	85	92	95					
	485. 696. 17. 05	2.95	159	220	333	392	462	559	640	2811	881	1070	86	93	95					
	485. 706. 17. 05	3.15	180	249	382	441	516	618	709	3114	968	1150	88	94	98					
	485. 716. 17. 05	3.32	199	274	425	489	580	704	806	3540	1118	1345	84	90	94					
6	485. 716. 17. 06	3.50	219	303	465	548	645	785	892	3918	1235	1495	86	92	97	11.00	10.56	.97	54	
	485. 726. 17. 06	3.25	199	274	425	489	580	704	806	3540	1118	1345	80	86	90					
	485. 736. 17. 06	3.40	219	303	465	548	645	785	892	3918	1235	1495	82	88	94					
	485. 746. 17. 06	3.62	241	333	520	602	710	860	978	4296	1355	1640	83	89	95					
	485. 756. 17. 06	3.87	265	366	560	656	774	935	1070	4700	1478	1770	86	89	98					
	485. 766. 17. 06	4.12	285	400	628	735	870	1065	1225	5381	1710	2100	87	94	96					
8	485. 736. 17. 08	4.62	310	435	675	795	950	1158	1325	5820	1870	2280	88	94	98	13.47	12.25	1.31	98	
	485. 756. 17. 08	3.50	268	370	555	650	760	915	1030	4524	1420	1700	63	70	70					
	485. 776. 17. 08	3.93	330	455	700	820	960	1150	1315	5776	1800	2150	80	87	90					
	485. 786. 17. 08	4.43	417	575	860	995	1160	1380	1575	6918	2120	2535	90	100	102					

Nozzle Inlet Flange Conn. (in.)	Ordering no.	Orifice diam.* (in.)	Flow Rate (Gallons Per Minute)									Spray Angle in degrees at			Dimensions (in.)		Free Passage (in.)	Approx. Wgt. (lb.)	
			1 psi	2 psi	4 psi	5 psi	7 psi	10 psi	15 psi	liters per minute	20 psi	25 psi	1 psi	2 psi	3 psi	B			C
10	485. 806. 17. 10	5.00	520	730	1030	1150	1370	1630	2000	8785	2300	2580	85	87	90	16.00	17.00	1.75	140
	485. 826. 17. 10	5.56	640	900	1270	1410	1660	2000	2450	10762	2850	3020	85	87	90				
	485. 836. 17. 10	6.00	760	1070	1510	1680	2000	2400	2930	12870	3360	3760	85	87	90				
12	485. 846. 17. 12	6.21	810	1140	1610	1780	2130	2550	3120	13705	3560	3980	85	87	90	19.00	20.00	2.06	200
	485. 856. 17. 12	6.59	890	1270	1790	2000	2370	2828	3460	15198	4000	4470	85	87	90				
	485. 866. 17. 12	7.06	1040	1460	2060	2300	2720	3250	4000	17570	4650	5200	85	87	90				
	485. 876. 17. 12	7.40	1130	1600	2260	2530	2990	3580	4380	19240	5060	5650	85	87	90				
16	485. 896. 17. 16	8.00	1350	1890	2660	2980	3510	4200	5150	22622	5940	6650	85	87	90	23.50	22.00	2.75	330
	485. 916. 17. 16	9.25	1690	2400	3390	3800	4500	5380	6580	28904	7600	8490	85	87	90				
18	485. 936. 17. 18	10.7	2220	3140	4450	4970	5880	7030	8610	37821	9940	1110	85	87	90	25.00	28.75	2.75	450

* Nozzles are manufactured to spray performance, not orifice diameter

Precision Spray Nozzles





Axial-flow full cone nozzles Series 460 / 461



Very uniform spray pattern.

Applications:

Cleaning and washing process, cooling of gaseous fluids and solids, surface spraying, spraying onto mats in air washers, improving of chemical reactions.

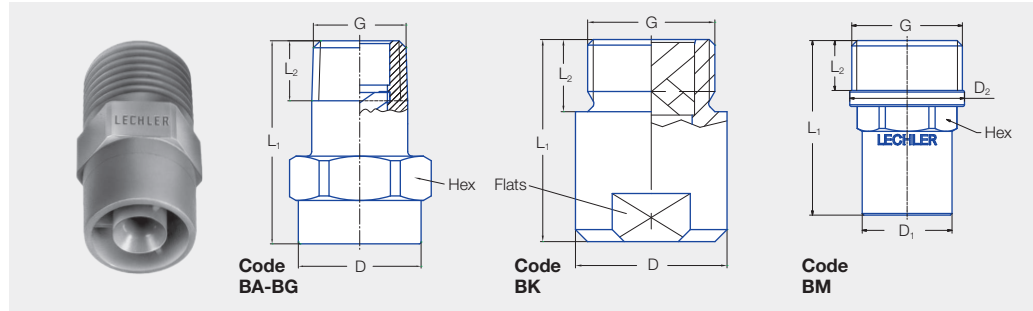

Code	Dimensions [in]					
	G	L ₁	L ₂	D ₁	D ₂	Hex/Flats
BA	1/8 NPT	.87	.26	.51	-	9/16
BC	1/4 NPT	.87	.38	.51	-	9/16
BE	3/8 NPT	1.18	.39	.67	-	11/16
BG	1/2 NPT	1.71	.52	.87	-	7/8
BK	3/4 NPT	1.65	.59	1.24	-	1-1/8
BM	1 NPT	2.07	.59	1.06	1.36	1-3/8

Subject to technical modifications. Please enquire about the exact dimensions if the installation situation is critical!

Spray angle	Ordering no.										Orifice diam. (in)	Free passage (in)	Flow Rate (Gallons Per Minute)										Spray Diam. D (in.) @ 30 psi	
	Type	Mat. no.		Conection						liters per minute										H = 8"	H = 20"			
		PVDF 5E	Polypro 53	Male NPT						10 psi			20 psi	2 bar	30 psi	40 psi	60 psi	80 psi	100 psi			150 psi		
60°	460.644	○	-	-	BC	BE	-	-	-	-	.095	.075	.69	.91	4.0	1.1	1.2	1.4	1.6	1.7	2.0	9	22	
	460.964	○	-	-	-	-	-	-	BK	-	.229	.193	4.3	5.7	25	6.7	7.5	8.8	9.9	10.8	12.7	9	22	
90°	460.326	○	-	-	BA	-	-	-	-	-	.032	.022	.07	.09	0.4	.11	.12	.14	.16	.17	.20	15	34	
	460.406	○	-	-	BA	-	-	-	-	-	.047	.033	.17	.23	1.0	.27	.30	.35	.40	.43	.51	15	34	
	460.486	○	-	-	BA	-	-	-	-	-	.057	.047	.28	.36	1.6	.43	.48	.57	.63	.69	.82	15	34	
	460.526	○	-	-	BA	-	-	-	-	-	.065	.051	.35	.46	2.0	.54	.60	.71	.79	.87	1.0	15	34	
	460.606	○	-	-	BA	-	BE	-	-	-	.081	.057	.54	.72	3.2	.84	.95	1.1	1.2	1.4	1.6	15	34	
	460.646	○	-	-	BC	BE	-	-	-	-	.091	.071	.69	.91	4.0	1.1	1.2	1.4	1.6	1.7	2.0	15	38	
	460.726	○	-	-	-	BE	-	-	-	-	.116	.079	1.1	1.4	6.3	1.7	1.9	2.2	2.5	2.7	3.2	15	38	
	460.746	○	-	-	-	BE	-	-	-	-	.130	.075	1.2	1.6	7.1	1.9	2.1	2.5	2.8	3.1	3.6	15	38	
	460.766	○	-	-	-	BE	-	-	-	-	.130	.095	1.4	1.8	8.0	2.1	2.4	2.8	3.2	3.5	4.1	15	38	
	460.806	○	-	-	-	BE	-	-	-	-	.146	.106	1.7	2.3	10.0	2.7	3.0	3.5	4.0	4.3	5.1	15	38	
	460.846	○	-	-	-	BE	-	-	-	-	.160	.126	2.2	2.8	12.5	3.3	3.8	4.4	5.0	5.4	6.4	15	38	
	460.886	○	-	-	-	BE	BG	-	-	-	.185	.122	2.8	3.6	16.0	4.3	4.8	5.7	6.3	6.9	8.2	15	38	
	460.926	○	-	-	-	-	BG	-	-	-	.205	.150	3.5	4.6	20	5.4	6.0	7.1	7.9	8.7	10.2	15	38	
	460.966	○	-	-	-	-	BG	BK	-	-	.229	.150	4.3	5.7	25	6.7	7.5	8.8	9.9	10.8	12.7	15	38	
	461.006	○	-	-	-	-	BG	-	-	-	.252	.150	5.4	7.2	32	8.4	9.5	11.1	12.5	13.7	16.1	15	38	
	461.046	○	○	-	-	-	-	BK	-	-	.284	.209	6.9	9.1	40	10.7	12.0	14.1	15.9	17.3	20	15	38	
	461.086	○	-	-	-	-	-	BK	-	-	.323	.209	8.6	11.4	50	13.4	15.0	17.7	19.8	22	25	15	38	
461.126	○	-	-	-	-	-	-	BM	-	.366	.256	10.9	14.3	63	16.9	18.9	22	25	27	32	15	38		
461.146	○	-	-	-	-	-	-	BM	-	.390	.264	12.3	16.2	71	19.0	21	25	28	31	36	15	38		



Continued on next page.

Example for ordering: 460.326 + Material no. + 5E + Code + BA = Ordering no. = 460.326.5E.BA



Axial-flow full cone nozzles Series 460 / 461



Spray angle 	Ordering no.										Orifice diam. (in)	Free passage (in)	Flow Rate (Gallons Per Minute)										Spray Diam. D (in.) @ 30 psi 	
	Type	Mat. no.		Conection						10 psi			20 psi	liters per minute 2 bar	30 psi	40 psi	60 psi	80 psi	100 psi	150 psi	H = 8"	H =20"		
		PVDf 5E	Polypro 53	Male NPT																				
				1/8"	1/4"	3/8"	1/2"	3/4"	1"															
120°	460. 408	○	-	BA	-	-	-	-	-	.047	.033	.17	.23	1.0	.27	.30	.35	.40	.43	.51	27	48		
	460. 488	○	-	BA	-	-	-	-	-	.059	.039	.28	.36	1.6	.43	.48	.57	.63	.69	.82	27	48		
	460. 528	○	-	BA	-	-	-	-	-	.065	.047	.35	.46	2.0	.54	.60	.71	.79	.87	1.0	27	48		
	460. 608	○	-	BA	-	-	-	-	-	.083	.055	.54	.72	3.2	.84	.95	1.1	1.2	1.4	1.6	1.6	27	48	
	460. 648	○	-	-	BC	BE	-	-	-	.097	.063	.69	.91	4.0	1.1	1.2	1.4	1.6	1.7	2.0	2.0	27	52	
	460. 728	○	-	-	-	BE	-	-	-	.122	.075	1.1	1.4	6.3	1.7	1.9	2.2	2.5	2.7	3.2	3.2	27	52	
	460. 748	○	-	-	-	BE	-	-	-	.130	.075	1.2	1.6	7.1	1.9	2.1	2.5	2.8	3.1	3.6	3.6	27	52	
	460. 768	○	-	-	-	BE	-	-	-	.150	.095	1.7	2.3	10.0	2.7	3.0	3.5	4.0	4.3	5.1	5.1	27	52	
	460. 808	○	-	-	-	BE	-	-	-	.150	.095	1.7	2.3	10.0	2.7	3.0	3.5	4.0	4.3	5.1	5.1	27	52	
	460. 848	○	-	-	-	BE	-	-	-	.165	.106	2.2	2.8	12.5	3.3	3.8	4.4	5.0	5.4	6.4	6.4	27	52	
	460. 888	○	-	-	-	BE	BG	-	-	.181	.122	2.8	3.6	16.0	4.3	4.8	5.7	6.3	6.9	8.2	8.2	27	52	
	460. 968	○	-	-	-	-	BG	-	-	.232	.162	4.3	5.7	25	6.7	7.5	8.8	9.9	10.8	12.7	12.7	27	52	
461. 048	-	○	-	-	-	-	BK	-	.299	.193	6.9	9.1	40	10.7	12.0	14.1	15.9	17.3	20	20	27	52		

Example Type + Material no. + Code = Ordering no.
for ordering: 460.408 + 5E + BA = 460.408.5E.BA

Precision Spray Nozzles

Conversion formula for the above series: $\dot{V}_2 = \dot{V}_1 * \left(\frac{p_2}{p_1}\right)^{0.4}$



Axial-flow full cone nozzles Series 455



One-piece design generates large droplets and even distribution at a wide range of operating pressures.

Applications:

High volume surface spraying, scrubbers, quench cooling and chemical processing.

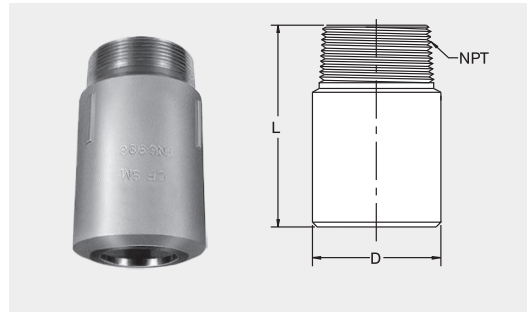

Dimensions (in.)			
Inlet (NPT)	L	D	Wt. (lb.)
Male			
2-1/2	6.06	3.75	3.5
3	6.31	3.87	6.5
Female			
2-1/2	6.06	3.75	3.5
3	6.31	3.87	6.5

Type	Ordering no.				* Orifice diam. (in.)	Free Passage (in.)	Flow Rate (Gallons Per Minute)										Spray Angle in degrees @ 15 psi	
	Mat. no.	Connection		liters per minute														
		Male NPT	Female NPT	1 psi			2 psi	5 psi	7 psi	10 psi	15 psi	20 psi	2.0 bar	40 psi	60 psi			
	316 SS 17	2 1/2"	3"	2 1/2"	3"													
455. 556	○	BY	-	BZ	-	1.37	.44	31	49	70	95	115	143	166	729	230	286	94
455. 576	○	BY	-	BZ	-	1.50	.44	41	56	91	108	132	164	190	834	264	328	101
455. 586	○	BY	-	BZ	-	1.62	.44	44	61	99	118	142	175	205	900	284	350	99
455. 596	○	BY	-	BZ	-	1.75	.44	47	65	105	125	150	185	215	944	300	390	102
455. 606	○	BY	-	BZ	-	1.87	.44	50	71	112	132	160	195	225	988	320	450	100
455. 616	○	-	MA	-	MB	1.68	.56	59	83	130	153	183	222	255	1120	358	438	85
455. 626	○	-	MA	-	MB	1.76	.56	67	94	145	170	200	245	280	1229	390	482	90
455. 636	○	-	MA	-	MB	1.93	.56	78	109	168	196	233	282	322	1414	446	545	96
455. 646	○	-	MA	-	MB	2.06	.56	88	121	185	216	255	309	350	1537	485	592	98
455. 656	○	-	MA	-	MB	2.25	.56	96	132	200	235	277	332	380	1669	522	640	100
455. 666	○	-	MA	-	MB	2.31	.56	100	138	212	248	292	352	404	1774	555	674	100

This product line is also available in larger capacities with threaded inlets ranging from 4" through 8" in size. Please contact your local representative or Lechler if you have an application requiring a Free Spray nozzle in a larger size.

Example Type + Material no. + Conn. = Ordering no.
for ordering: 455. 596 + 17 + BY = 455. 596. 17. BY

* Nozzles are manufactured to spray performance, not orifice diameter.



Axial-flow full cone nozzles Series 459



Turbine-style vane for uniform atomization and distribution.

Applications:

Surface spraying, quench cooling, fire suppression and chemical processing.

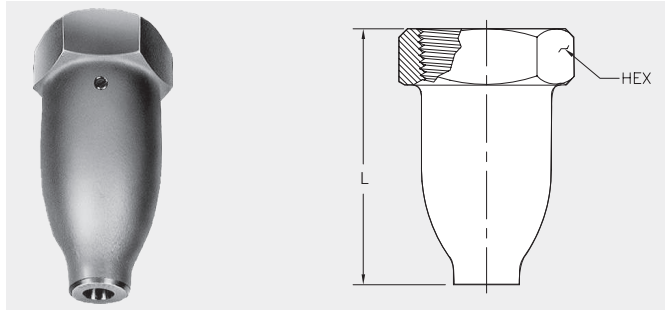

Dimensions (in.)			
Inlet (Female NPT)	L	HEX	Wt. (lb.)
1-1/2	4.31	2-3/16	1.8
2	5.45	2-3/4	2.4
2-1/2	6.00	3-1/4	4.18
3	6.89	3-7/8	6.0

Ordering no.				Orifice diam.* (in.)	Flow Rate (Gallons Per Minute)										Spray Angle in degrees @ 40 psi (* = 15 psi)	
Type	Mat. no. 17	Connection				5 psi	10 psi	20 psi	liters per minute		40 psi	60 psi	80 psi	100 psi		
		Female NPT	1 1/2"		2"				2 1/2"	3"						2
STANDARD ANGLE																
459. 244	○	BS	-	-	-	.500	14	20	27	124	38	47	54	60	62	
459. 284	○	BS	-	-	-	.625	18	25	36	165	50	62	71	79	62	
459. 355	○	BS	-	-	-	.687	26	37	52	233	72	86	100	112	70	
459. 356	○	BS	-	-	-	.687	26	37	52	233	72	86	100	112	84	
459. 343	○	-	BW	-	-	.500	25	35	48	222	68	82	94	105	43	
459. 365	○	-	BW	-	-	.656	28	39	53	242	72	86	98	110	*80	
459. 415	○	-	BW	-	-	.796	38	53	74	339	105	125	144	160	66	
459. 455	○	-	BW	-	-	.906	48	68	95	434	132	160	183	205	68	
459. 475	○	-	-	BZ	-	.910	54	75	104	475	143	172	200	221	83	
459. 515	○	-	-	BZ	-	1.06	68	94	132	603	185	225	260	290	67	
459. 584	○	-	-	-	MB	1.31	103	144	200	925	285	345	400	440	57	
WIDE ANGLE																
459. 238	○	BS	-	-	-	.562	15	20	27	124	37	45	51	56	120	
459. 266	○	BS	-	-	-	.500	14	19	26	117	35	42	48	53	98	
459. 286	○	BS	-	-	-	.625	18	25	36	165	50	62	71	79	94	
459. 288	○	BS	-	-	-	.625	19	26	36	162	49	58	66	73	120	
459. 348	○	BS	-	-	-	.781	26	36	49	226	69	83	95	105	120	
459. 378	○	-	BW	-	-	.781	33	45	61	273	82	98	110	122	118	
459. 386	○	-	BW	-	-	.796	37	50	68	311	92	111	129	141	*99	
459. 408	○	-	BW	-	-	.937	40	55	74	332	100	118	135	147	118	
459. 488	○	-	-	BZ	-	1.03	64	86	117	521	157	187	212	232	119	
459. 496	○	-	-	BZ	-	0.98	63	87	119	543	165	200	233	259	*86	
459. 575	○	-	-	-	MB	1.31	110	150	205	938	275	330	380	421	*90	
459. 608	○	-	-	-	MB	1.43	132	179	242	1095	328	390	440	485	120	

* Nozzles are manufactured to spray performance, not orifice diameter

This product line is also available in larger capacities with inlets up to 6" in size. Please contact your local representative or Lechler if you have an application requiring a larger size.

Example Type + Material no. + Conn. = Ordering no.
for ordering: 459. 455 + 17 + BW = 459. 455. 17. BW

Precision Spray Nozzles



Axial-flow full cone nozzles Series 405



Very uniform spray pattern.

Applications:

Surface spraying, spraying over packings, cleaning and washing process, chemical process engineering, cooling of gaseous fluids and solids, water treatment.

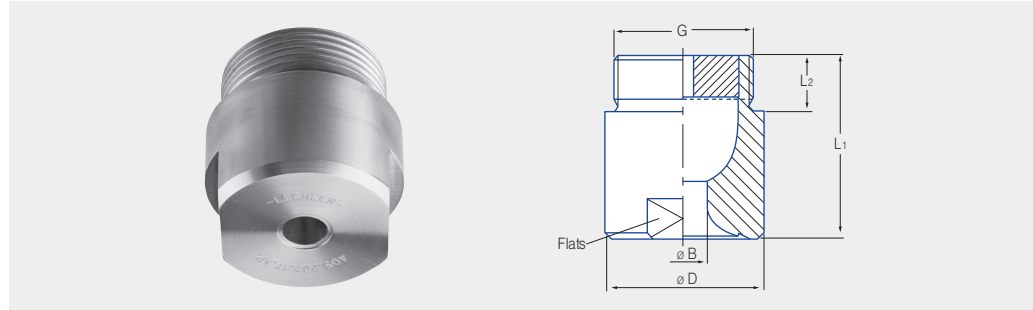

Dimensions (in.)					
G (Male NPT)	L1	L2	D	Flats	Wt. brass (lb.)
1-1/4	1.97	.75	1.93	1-5/8	1.16
1-1/2	2.36	.75	2.32	2	2.02
2	3.07	.94	2.68	2-3/8	3.39

Spray angle	Ordering no.			Orifice diam. (in.)	Free passage (in.)	Flow Rate (Gallons Per Minute)							Spray Diam. D (in.) @ 30 psi			
	Type	Material no. 316L SS 1Y	Connection			liters per minute			psi				H=20"	H=40"		
			1 1/4"			1 1/2"	2"	2	30	40	60	5			10	20
60°	405.204	○	BP	-	-	.441	.229	13	17	23	100	27	30	35	22	41
	405.284	○	-	BR	-	.563	.276	21	28	36	160	43	48	57	23	43
	405.324	○	-	-	BV	.646	.296	26	35	46	200	54	60	71	23	43
	405.364	○	-	-	BV	.725	.335	33	43	57	250	67	75	88	23	43
	405.404	○	-	-	BV	.788	.276	41	54	72	315	85	95	111	23	43
90°	405.206	○	BP	-	-	.473	.197	13	17	23	100	27	30	35	31	57
	405.286	○	-	BR	-	.599	.244	21	28	36	160	43	48	57	31	61
	405.326	○	-	-	BV	.678	.303	26	35	46	200	54	60	71	33	63
	405.366	○	-	-	BV	.768	.343	33	43	57	250	67	75	88	33	63
	405.406	○	-	-	BV	.867	.374	41	54	72	315	85	95	111	33	63
120°	405.208	○	BP	-	-	.500	.197	13	17	23	100	27	30	35	57	102
	405.288	○	-	BR	-	.630	.260	21	28	36	160	43	48	57	59	106
	405.328	○	-	-	BV	.701	.311	26	35	46	200	54	60	71	59	110
	405.368	○	-	-	BV	.792	.347	33	43	57	250	67	75	88	59	110
	405.408	○	-	-	BV	.883	.359	41	54	72	315	85	95	111	59	110

Example Type + Material no. + Conn. = Ordering no.
for ordering: 405.204 + 1Y + BP = 405.204.1Y.BP

Precision Spray Nozzles



Axial-flow full cone nozzles Series 403



Very uniform spray pattern.

Applications:

Surface spraying, spraying over packings, chemical process engineering, cooling of gaseous fluids and solids.

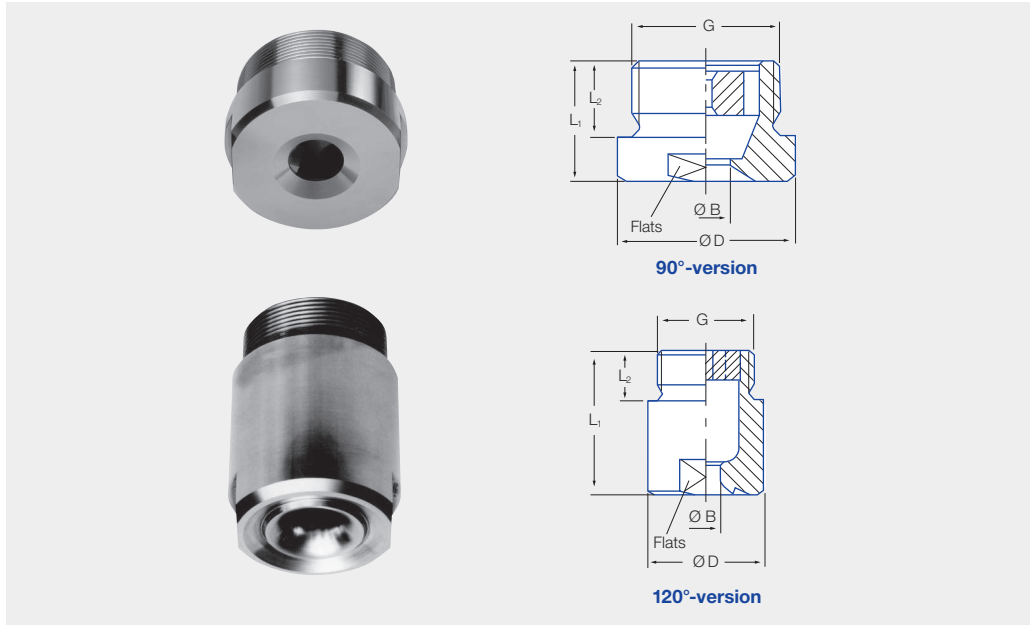

Other nozzle sizes and materials are available on request.

90°-version

G (Male NPT)	Dimensions (in.)				Wt. (lb.)
	L1	L2	D	Flats	
2-1/2	2.0	1.1	3.3	3.0	2.9
3	2.4	1.2	3.9	3.3	3.7
3-1/2	2.8	1.3	4.6	4.1	8.4

120°-version

G (Male NPT)	Dimensions (in.)				Wt. (lb.)
	L1	L2	D	Flats	
2-1/2	4.9	1.1	3.3	3.0	6.6
3	6.0	1.2	3.9	3.3	11.5
3-1/2	6.1	1.3	4.6	4.1	18.5
4	6.5	1.4	5.0	4.3	21.0

Spray angle	Ordering no.				Orifice diam. (in.)	Free passage (in.)	Flow Rate (Gallons Per Minute)										Spray Diam. D (in.) @ 30 psi			
	Type	Mat. no. 316L SS 1Y	Connection				liters per minute					Gallons Per Minute					H=20"	H=40"		
			2 1/2"	3"			3 1/2"	4"	2 bar	30 psi	40 psi	60 psi	80 psi	100 psi						
90°	403.446	○	BY	-	-	-	.985	.473	52	69	91	400	107	120	141	159	173	35	67	
	403.486	○	BY	-	-	-	1.162	.473	65	86	114	500	134	150	177	198	217	35	67	
	403.526	○	-	MA	-	-	1.000	.544	82	109	143	630	169	189	223	250	273	35	67	
	403.606	○	-	-	MC	-	1.576	.591	131	173	228	1000	269	300	353	396	433	38	69	
120°	403.448	○	BY	-	-	-	1.005	.394	52	69	91	400	107	120	141	159	173	59	112	
	403.488	○	BY	-	-	-	1.162	.433	65	86	114	500	134	150	177	198	217	59	112	
	403.528	○	-	MA	-	-	1.261	.591	82	109	143	630	169	189	223	250	273	59	112	
	403.568	○	-	-	MC	-	1.497	.473	105	138	182	800	215	240	283	317	347	59	112	
	403.608	○	-	-	MC	-	1.655	.473	131	173	228	1000	269	300	353	396	433	59	112	
	403.628	○	-	-	-	ME	1.773	.591	163	216	285	1250	336	375	442	495	542	63	114	

Example Type + Material no. + Conn. = Ordering no.
for ordering: 403.448 + 1Y + BY = 403.448.1Y.BY

Conversion formula for the above series: $\dot{V}_2 = \dot{V}_1 * \left(\frac{p_2}{p_1}\right)^{0.4}$



Axial-flow full cone nozzles Series 419 »FreeFlow«



FreeFlow

Particularly insensitive to clogging thanks to very large free cross sections.
Stable spray angle.
Uniform spray pattern

Applications:

- Gas washing
- Spraying over packings
- Dust control
- Absorption
- Distillation

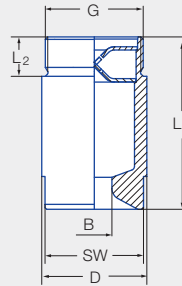

Figure 1

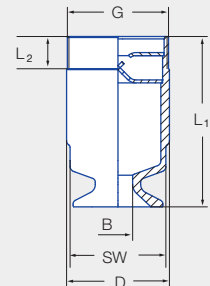

Figure 2

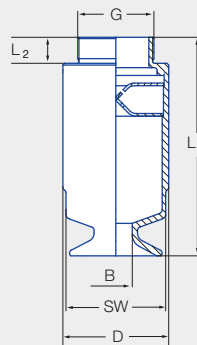
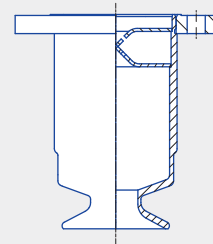

Figure 3





Other materials and flange versions are available on request

Spray Angle	Type	Code	Figure	Dimensions [in]					Weight (lbs)
				G NPT Male	L ₁	L ₂	D	Flats	
90° + 120°	419.3XX	BR	3	1 1/2	5.20	.87	2.52	2-3/8	3.31
		BV	1	2	4.49	.94	2.52	2-3/8	2.65
	419.4XX	BV	3	2	6.42	1.06	3.15	2-15/16	4.41
		BY	2	2 1/2	5.28	.94	3.15	2-15/16	3.75
	419.51X 419.54X	BV	3	2	7.83	1.06	4.02	3-3/4	8.16
		BY	3	2 1/2	7.95	1.18	4.02	3-3/4	8.38
		MA	3	3	8.07	1.26	4.02	3-3/4	11.46
	419.57X	MC	2	3 1/2	6.65	1.06	4.02	3-3/4	7.05
		BY	3	2 1/2	9.09	1.18	4.53	4-1/8	11.46
		MA	3	3	9.17	1.42	4.53	4-1/8	11.46
	419.6XX	ME	2	4	7.64	.36	4.53	4-1/8	9.70
		MA	3	3	9.92	.30	4.41	4-9/16	11.90
		MC	3	3 1/2	10.00	.32	4.41	4-9/16	12.13

G= Thread size • L₁ = Total Length • L₂ = Thread Length • D = Outer diameter • Flats = Wrench size



Axial-flow full cone nozzles Series 419 »FreeFlow«

Spray angle 	Ordering no.									B Ø [in]	E Ø [in]	Flow Rate (Gallons Per Minute)					Spray Diameter D [in] at p = 15 psi 	
	Type	Mat. -Nr.		Code								5 psi	10 psi	15 psi	30 psi	75 psi	H = 20 in	D = 40 in
		1Y	2P	1 1/2 Male NPT	2 Male NPT	2 1/2 NPT male	3 NPT male	3 1/2 NPT male	4 NPT male									
90°	419.366	○	○	BR	BV	-	-	-	-	.70	.69	33	43	51	67	97	39	79
	419.396	○	○	BR	BV	-	-	-	-	.81	.69	39	52	61	80	116	39	79
	419.446	○	○	-	BV	BY	-	-	-	.91	.81	52	69	81	107	155	39	79
	419.486	○	○	-	BV	BY	-	-	-	1.10	.81	65	86	101	134	193	39	79
	419.516	○	○	-	BV	BY	MA	MC	-	1.07	.95	78	104	122	161	232	39	79
	419.546	○	○	-	BV	BY	MA	MC	-	1.30	.95	93	124	144	190	274	39	79
	419.576	○	○	-	-	BY	MA	-	ME	1.34	1.07	111	147	172	228	328	39	79
	419.606	○	○	-	-	-	MA	MC	-	1.48	1.19	131	172	203	268	386	39	79
419.626	○	○	-	-	-	MA	MC	-	1.69	1.19	163	216	254	335	483	39	79	
120°	419.368	○	○	BR	BV	-	-	-	-	.81	.69	33	43	51	67	97	67	114
	419.398	○	○	BR	BV	-	-	-	-	.93	.69	39	52	61	80	116	67	114
	419.448	○	○	-	BV	BY	-	-	-	.96	.81	52	69	81	107	155	67	114
	419.488	○	○	-	BV	BY	-	-	-	1.16	.81	65	86	101	134	193	67	114
	419.518	○	○	-	BV	BY	MA	MC	-	1.07	.95	78	104	122	161	232	67	114
	419.548	○	○	-	BV	BY	MA	MC	-	1.34	.95	93	124	144	190	274	67	114
	419.578	○	○	-	-	BY	MA	-	ME	1.34	1.13	111	147	172	228	328	67	114
	419.608	○	○	-	-	-	MA	MC	-	1.50	1.27	131	172	203	268	386	67	114
419.628	○	○	-	-	-	MA	MC	-	1.71	1.27	163	216	254	335	483	67	114	

B = Orifice diameter-Ø · E = Free passage · * Spray angle at 15 psi

Example Type + Material-Nr. + Code = Ordering no.
for ordering: 419.366 + 1Y BR = 419.366.1Y.BR

Conversion formula for the above series: $V_2 = V_1 * \left(\frac{p_2}{p_1}\right)^{0.4}$



Axial-flow full cone nozzles Series 421



**Even full cone distribution,
high flow rates.**

Applications:

Scrubber, for even surface irrigation, cooling and cleaning of gases, water recooling, column irrigation and for improving chemical reactions via surface enlargement.

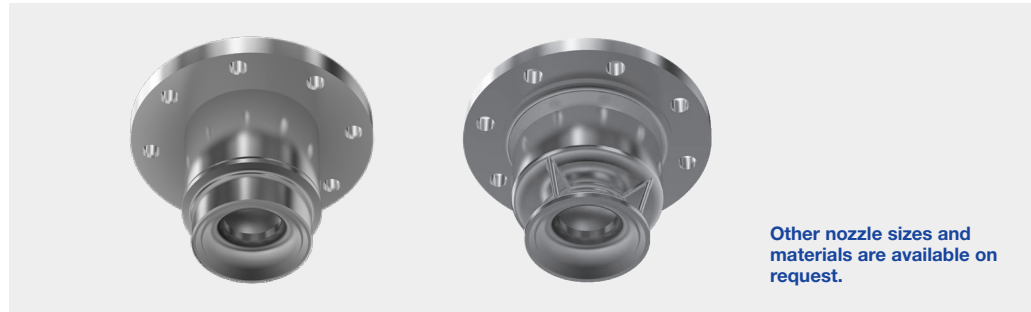

Other nozzle sizes and materials are available on request.

Spray angle*	Ordering no.				B Ø [in]	E Ø [in]	Flow Rate (Gallons Per Minute)					
	Type	Mat. no.					4 psi	7 psi	14.5 psi	Liters per minute		
		05.84 GG	1Y.84 316L SS	53.00 PP						2 bar	72 psi	145 psi
60°	421.564	○	-	○	1.46	0.47	99	121	160	800	305	402
	421.604	○	-	○	1.54	0.55	124	152	200	1000	381	503
	421.624	○	○	○	1.61	0.51	155	190	250	1250	476	629
	421.644	○	○	○	1.93	0.63	198	243	320	1600	610	805
	421.664	○	○	○	2.20	0.63	247	304	400	2000	762	1006
	421.684	○	○	○	2.28	0.83	309	379	501	2500	953	1257
	421.704	○	○	○	2.56	0.94	390	478	631	3150	1201	1584
	421.724	-	○	○	2.83	1.18	495	607	801	4000	1525	2012
	421.744	-	○	○	3.19	1.34	618	759	1001	5000	1906	2514
	421.764	-	○	○	3.46	1.38	779	956	1261	6300	2401	3168
	421.784	-	○	○	3.90	1.54	990	1214	1602	8000	3049	4023
	421.804	-	○	-	4.41	1.65	1237	1517	2002	10000	3811	5029
421.824	-	○	-	4.92	2.05	1546	1896	2503	12500	4764	6286	
90°	421.566	○	-	○	1.46	0.59	99	121	160	800	305	402
	421.606	○	-	○	1.54	0.59	124	152	200	1000	381	503
	421.626	○	○	○	1.69	0.75	155	190	250	1250	476	629
	421.646	○	○	○	2.09	0.87	198	243	320	1600	610	805
	421.666	○	○	○	2.20	0.94	247	304	400	2000	762	1006
	421.686	○	○	○	2.32	1.10	309	379	501	2500	953	1257
	421.706	○	○	○	2.60	1.26	390	4790	631	3150	1201	1584
	421.726	-	○	○	2.83	1.38	495	607	801	4000	1525	2012
	421.746	-	○	○	3.19	1.57	618	759	1001	5000	1906	2514
	421.766	-	○	○	3.66	1.54	779	956	1261	6300	2401	3168
	421.786	-	○	○	3.90	1.73	990	1214	1602	8000	3049	4023
	421.806	-	○	○	4.84	2.09	1237	1517	2002	10000	3811	5029
421.826	-	○	-	4.92	2.13	1543	1896	2502	12500	4764	6286	
120°	421.568	○	○	○	1.42	0.59	99	121	160	800	305	402
	421.608	○	○	○	1.61	0.59	124	152	200	1000	381	503
	421.628	○	○	○	1.69	0.75	155	190	250	1250	476	629
	421.648	○	○	○	2.09	0.87	198	243	320	1600	610	805
	421.668	○	○	○	2.17	0.94	247	303	400	2000	762	1006
	421.688	○	○	○	2.32	1.10	309	379	501	2500	953	1257
	421.708	○	○	○	2.60	1.26	390	478	631	3150	1201	1584
	421.728	-	○	○	2.83	1.38	495	607	801	4000	1525	2012
	421.748	-	○	○	3.19	1.57	618	759	1001	5000	1906	2514
	421.768	-	○	○	3.46	1.54	779	956	1261	6300	2401	3168
	421.788	-	○	○	3.90	1.73	990	1214	1602	8000	3049	4023
	421.808	-	○	○	4.25	2.09	1237	1517	2002	10000	3811	5029
421.828	-	○	○	4.76	2.13	1546	1896	253	12500	4764	6286	

B = bore diameter · E = narrowest free cross section

* Spray angle at p = 30 psi



Axial-flow full cone nozzles Series 421

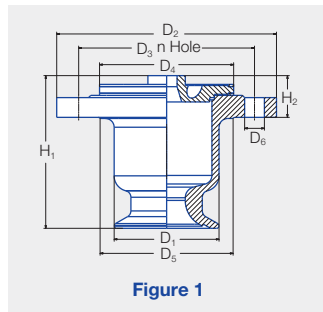

Figure 1

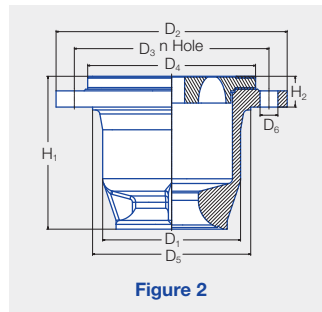

Figure 2

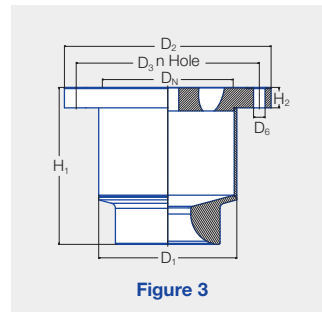

Figure 3

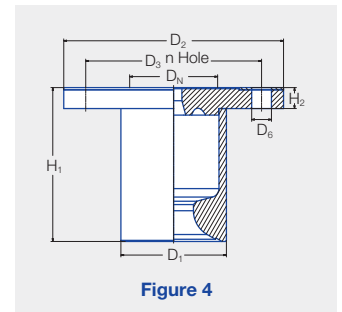



Figure 4

Spray angle 	Type	Mat. no.	Fig.	Dimensions [mm]									Flange hole	
				H ₁	H ₂	D ₁	D ₂	D ₃	D ₄	D ₅	D _N	Number	D ₆	
60°-90° 120° 120° 60°-120°	421.56x/ 421.60x	05.84	1	134	39	96	200	160	122	121	80	8	18	
		05.84	1	140	39	96	200	160	122	121	80	8	18	
		1Y.84	3	140	19	96	200	160	-	-	80	8	18	
		53.00	4	131	44	99	200	160	-	-	80	8	18	
60°-120°	421.62x	05.84	1	156	28	113	220	180	158	141	100	8	18	
		1Y.84	3	156	20	108	220	180	-	-	100	8	18	
		53.00	4	156	53	117	220	180	-	-	100	8	18	
		05.84	2	175	42	140	250	210	188	166	125	8	18	
60°-90° 120° 60°-120° 60°-120°	421.64x/ 421.66x	05.84	2	175	29	140	250	210	188	166	125	8	18	
		05.84	2	175	29	140	250	210	188	166	125	8	18	
		1Y.84	3	175	19	135	250	210	-	-	125	8	18	
		53.00	4	175	57	141	250	210	-	-	125	8	18	
60°-120°	421.68x/ 421.70x	05.84	2	186	38	170	285	240	207	195	150	8	22	
		1Y.84	3	186	27	160	285	240	-	-	150	8	22	
		53.00	4	186	51	171	285	240	-	-	150	8	23	
		1Y.84	3	250	33	214	340	295	-	-	200	8	22	
60°-120°	421.72x/ 421.74x	53.00	4	250	50	225	340	295	-	-	200	8	23	
		1Y.84	3	300	39	264	395	350	-	-	250	12	22	
60°-120°	421.76x/ 421.78x	53.00	4	300	53	280	395	350	-	-	250	12	23	
		1Y.84	3	300	39	264	395	350	-	-	250	12	23	
60°-120°	421.80x/ 421.82x	1Y.84	3	367	49	315	445	400	-	-	300	12	22	
		53.00	4	367	57	328	445	400	-	360	300	12	23	

Example Type + Material no. = Ordering no.
for ordering: 421.564 + 05.84 = 421.564.05.84

Conversion formula for the above series: $\dot{V}_2 = \dot{V}_1 * \left(\frac{p_2}{p_1}\right)^{0.4}$



Tangential-flow full cone nozzles Series 422 / 423 Metal version



Tangentially arranged liquid supply. Without swirl inserts.
Non-clogging.
Stable spray angle.
Uniform spray.

Applications:

Cleaning and washing process, cooling of gaseous fluids and solids, surface spraying, spraying onto mats in air washers, improving of chemical reactions, continuous casting, foam control.

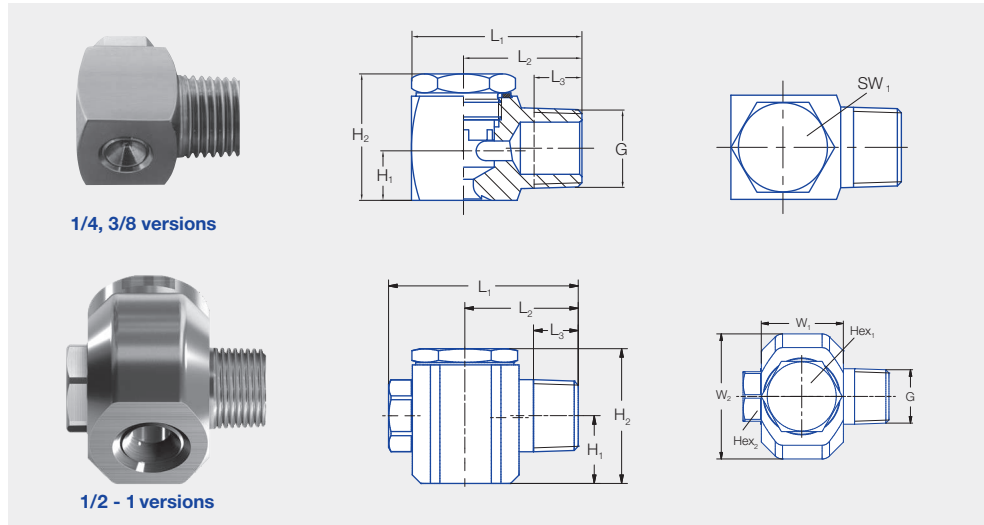

Dimensions [in]											Weight (lb.)
G (male NPT)	L ₁	L ₂	L ₃	H ₁	H ₂	W ₁	W ₂	Hex ₁	Hex ₂		
1/4"	1.1	.79	.38	.31	.83	.61	.63	.43	-	.097	
3/8"	1.42	.98	.4	.43	1.05	.91	.87	.75	-	.222	
1/2"	2.2	1.32	.52	.79	1.57	1.26	1.89	1.06	0.75	.816	
3/4"	2.58	1.52	.57	.93	2.24	1.5	2.48	1.42	1.06	1.83	
1"	3.35	1.91	.66	1.07	2.6	2.17	3.07	1.61	1.42	3.49	

Spray angle	Type	Mat. no.		Ordering no.								Orifice diam. (in.)	Free passage (in.)	Flow Rate (Gallons Per Minute)							Spray Diam. D (in.) @ 40 psi	
		AISI 316L	Brass	Connection										liters per minute	40 psi	60 psi	80 psi	100 psi	H=8"	H=20"		
		1Y	30	1/4"	3/8"	1/2"	3/4"	1"	1 1/4"	1 1/2"	2"										10 psi	20 psi
60°	422. 644	○	○	-	BE	-	-	-	-	-	-	.118	.118	.62	.88	4.0	1.2	1.5	1.8	2.0	9	20
90°	422. 406	○	○	BC	-	-	-	-	-	-	-	.059	.057	.16	.22	1.0	.31	.38	.44	.49	15	34
	422. 486	○	○	BC	-	-	-	-	-	-	-	.075	.071	.25	.35	1.6	.50	.61	.70	.78	15	34
	422. 566	○	○	BC	-	-	-	-	-	-	-	.091	.087	.39	.55	2.5	.78	.95	1.1	1.2	15	34
	422. 606	○	○	-	BE	-	-	-	-	-	-	.102	.099	.49	.69	3.2	.98	1.2	1.4	1.6	15	34
	422. 646	○	○	-	BE	-	-	-	-	-	-	.118	.114	.62	.88	4.0	1.2	1.5	1.8	2.0	15	38
	422. 766	○	-	-	BE	-	-	-	-	-	-	.164	.162	1.2	1.8	8.0	2.5	3.0	3.5	3.9	15	38
	422. 886	○	○	-	BE	-	-	-	-	-	-	.229	.225	2.5	3.5	16.0	5.0	6.1	7.0	7.9	15	38
	422. 966	○	-	-	-	BG	-	-	-	-	-	.315	.315	3.9	5.5	25	7.8	9.5	11.0	12.3	15	38
	423. 006	○	-	-	-	BG	-	-	-	-	-	.343	.343	4.8	6.8	31	9.6	11.8	13.6	15.2	15	38
	423. 046	○	-	-	-	-	BK	-	-	-	-	.426	.402	6.2	8.8	40	12	15	18	20	15	38
	423. 086	○	-	-	-	-	BK	-	-	-	-	.449	.433	7.8	11.0	50	15.5	19.0	22	25	15	38
	423. 126	○	-	-	-	-	BK	-	-	-	-	.500	.485	9.8	13.8	63	19.5	24	28	31	15	38
	423. 146	○	-	-	-	-	-	BM	-	-	-	.552	.532	11.0	15.6	71	22	27	31	35	15	38
	423. 206	○	-	-	-	-	-	BM	-	-	-	.670	.630	15.5	21.9	100	31	38	44	49	15	38
423. 286	○	-	-	-	-	-	-	BP	-	-	.748	.748	25.0	35.0	160	50	61	71	79	15	38	
423. 366	○	-	-	-	-	-	-	-	BR	-	.875	-	38.0	54.0	246	76	93	107	120	15	38	
423. 406	○	-	-	-	-	-	-	-	BV	-	-	-	49.0	69.0	315	98	120	139	155	15	38	
423. 446	○	-	-	-	-	-	-	-	BV	-	-	-	62.0	88.0	400	124	152	175	196	27	38	

Different metallurgies may be available upon request.

Continued on next page.

Example Type + Material no. + Conn. = Ordering no.
 for ordering: 422. 848 + 1Y + BE = 422. 848. 1Y. BE



Tangential-flow full cone nozzles Series 422 / 423 Metal version



Spray angle	Ordering no.										Orifice diam. (in.)	Free passage (in.)	Flow Rate (Gallons Per Minute)						Spray Diam. D (in.) @ 40 psi		
	Type	Mat. no.		Connection									10 psi	20 psi	liters per minute 2 bar	40 psi	60 psi	80 psi	100 psi	H=8"	H=20"
		ANSI 316L	Brass	Male NPT																	
		1Y	30	1/4"	3/8"	1/2"	3/4"	1"	1 1/4"	1 1/2"											
120°	422. 568	○	○	BC	-	-	-	-	-	-	.091	.087	.39	.55	2.5	.78	.95	1.1	1.2	27	48
	422. 728	○	○	-	BE	-	-	-	-	-	.146	.142	.98	1.4	6.3	2.0	2.4	2.8	3.1	27	63
	422. 808	○	-	-	BE	-	-	-	-	-	.183	.181	1.6	2.2	10.0	3.1	3.8	4.4	4.9	27	63
	422. 848	○	○	-	BE	-	-	-	-	-	.205	.201	1.9	2.7	12.5	3.9	4.8	5.5	6.1	27	63
	422. 888	○	○	-	BE	-	-	-	-	-	.229	.225	2.5	3.5	16.0	5.0	6.1	7.0	7.9	27	63
	422. 928	○	-	-	-	BG	-	-	-	-	.288	.288	3.1	4.4	20	6.2	7.6	8.8	9.8	27	63
	422. 968	○	○	-	-	BG	-	-	-	-	.315	.315	3.9	5.5	25	7.8	9.5	11.0	12.3	27	63
	423. 008	○	-	-	-	BG	-	-	-	-	.343	.343	4.8	6.8	31	9.6	11.8	13.6	15.2	27	63
	423. 128	○	-	-	-	-	BK	-	-	-	.500	.485	9.8	13.8	63	19.5	24	28	31	27	63
	423. 208	○	-	-	-	-	-	BM	-	-	.670	.630	15.5	21.9	100	31	38	44	49	27	63

Example Type + Material no. + Conn. = Ordering no.
for ordering: 422. 848 + 1Y + BE = 422. 848. 1Y. BE



Tangential-flow full cone nozzles

Plastic version

Series 422 / 423



Tangentially arranged liquid supply. Without swirl inserts. Non-clogging. Stable spray angle. Uniform spray.

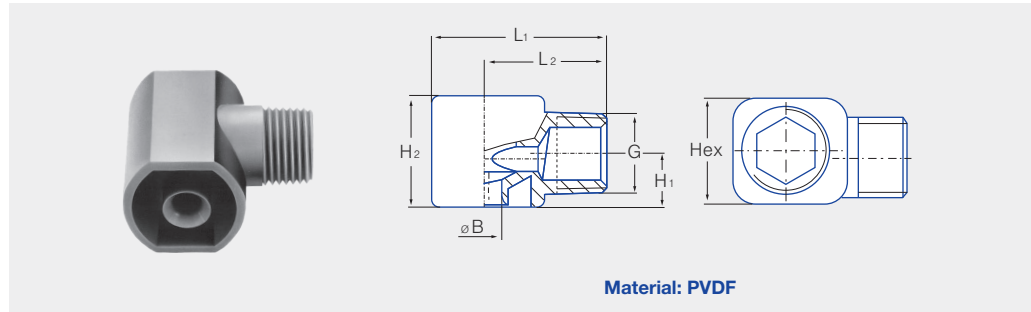

Applications:

Cleaning and washing processes, surface spraying, bottle cleaning, keg cleaning, sausage showers, foam control, degassing, pasteurization.



Material: PVDF

Dimensions [in]						Weight (lb.)
Inlet	L ₁	L ₂	H ₁	H ₂	Hex	
1/4 NPT	1.10	.79	.31	.63	5/8	.02
3/8 NPT	1.42	.98	.44	.91	7/8	.04
1/2 BSPT	1.95	1.32	.76	1.50	1-5/16	.09
3/4 BSPT	2.30	1.52	.96	1.97	1-5/8	.11

Spray angle 	Ordering no.						Orifice diam. (in.)	Free passage (in.)	Flow Rate (Gallons Per Minute)							Spray Diameter D (in.) @ 40 psi 			
	Type	Mat. no. 5E PVDF	Connection						10 psi	20 psi	liters per minute			40 psi	60 psi	80 psi	100 psi	H = 8"	H = 20"
			Male NPT 1/4"	Male NPT 3/8"	Male BSPT 1/2"	Male BSPT 3/4"					2 bar	40 psi	60 psi						
60°	422.724	○	-	BE	-	-	.142	.142	.98	1.4	6.3	2.0	2.4	2.8	3.1	9	20		
90°	422.406	○	BC	-	-	-	.059	.057	.16	.22	1.0	.31	.38	.44	.49	15	34		
	422.566	○	BC	-	-	-	.075	.071	.25	.35	1.6	.50	.61	.70	.78	15	34		
	422.606	○	-	BE	-	-	.091	.087	.39	.55	2.5	.78	.95	1.1	1.2	15	34		
	422.646	○	-	BE	-	-	.102	.099	.49	.69	3.2	.98	1.2	1.4	1.6	15	34		
	422.726	○	-	BE	-	-	.118	.114	.62	.88	4.0	1.2	1.5	1.8	2.0	15	38		
	422.806	○	-	BE	-	-	.146	.142	.98	1.4	6.3	2.0	2.4	2.8	3.1	15	38		
	422.846	○	-	BE	-	-	.183	.181	1.6	2.2	10.0	3.1	3.8	4.4	4.9	15	38		
	422.886	○	-	BE	-	-	.205	.201	1.9	2.7	12.5	3.9	4.8	5.5	6.1	15	38		
	422.926	○	-	-	CG	-	.229	.225	2.5	3.5	16.0	5.0	6.1	7.0	7.9	15	38		
	422.966	○	-	-	CG	-	.288	.288	3.1	4.4	20	6.2	7.6	8.8	9.8	15	38		
423.006	○	-	-	CG	-	.315	.315	3.9	5.5	25	7.8	9.5	11.0	12.3	15	38			
423.126	○	-	-	-	CK	.473	.473	9.8	13.8	63	19.5	24	28	31	15	38			
120°	422.408	○	BC	-	-	-	.059	.057	.16	.22	1.0	.31	.38	.44	.49	27	63		
	422.448	○	BC	-	-	-	.065	.063	.19	.26	1.2	.37	.46	.53	.59	27	63		
	422.488	○	BC	-	-	-	.075	.071	.25	.35	1.6	.50	.61	.70	.78	27	63		
	422.568	○	BC	-	-	-	.091	.087	.39	.55	2.5	.78	.95	1.1	1.2	27	63		
	422.728	○	-	BE	-	-	.146	.142	.98	1.4	6.3	2.0	2.4	2.8	3.1	27	63		
	422.888	○	-	BE	-	-	.229	.225	2.5	3.5	16.0	5.0	6.1	7.0	7.9	27	63		
	423.008	○	-	-	CG	-	.343	.343	4.8	6.8	31	9.6	11.8	13.6	15.2	27	63		
	423.128	○	-	-	-	CK	.500	.485	9.8	13.8	63	19.5	24	28	31	27	63		

B = bore diameter · E = narrowest free cross section

Example Type + Material-no. + Code = Ordering no.
of ordering: 422.724 + 5E + BE = 422.724.5E.BE



Cluster head nozzles Series 502 / 503

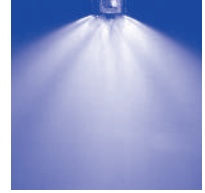

Fine full cone atomization with the aid of several hollow cones spraying into one another.

Applications:

Cooling of gaseous and solid material, desuperheating, chlorine precipitation, absorption as well as for improvement of chemical reaction by enlarging the contact area.



±70°

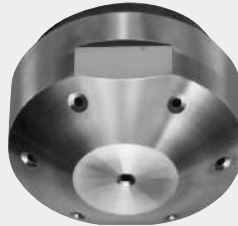

±130°

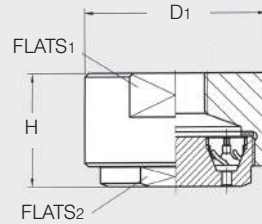

70° Version		
Dimensions (in.)		
	1/2"	3/4"
FLATS1	1.8	2.6
FLATS2	1.5	2.2
H	1.0	1.8
D	2.0	3.0
Weight (Brass)	.55 lb.	1.92 lb.

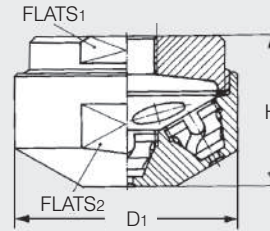

130° Version		
Dimensions (in.)		
	1/2"	3/4"
FLATS1	1.1	2.0
FLATS2	1.4	2.2
H	1.1	2.1
D	1.6	2.4
Weight (Brass)	.33 lb.	.90 lb.

Spray angle	Type	Ordering no.			Orifice diam. (in.)	Free passage (in.)	Flow Rate (Gallons Per Minute)								Spray Diam. D (in.) @ 30 psi	
		Material no.		Connection			10 psi	20 psi	liters per minute 2 bar	30 psi	40 psi	60 psi	80 psi	100 psi	H=40"	H=80"
		316 SS 17	Brass 30													
70°	502. 445	-	○	BH -	.039	.020	.19	.27	1.3	.35	.39	.48	.55	.61	16	16
	502. 985	○	-	- BL	.138	.079	4.3	6.1	28	7.5	8.7	10.6	12.3	13.7	47	59
	503. 065	○	-	- BL	.197	.079	7.0	9.9	45	12.1	14.0	17.1	19.8	22	47	70
	503. 115	○	○	- BL	.236	.079	9.2	13.1	60	16.1	18.7	23	26	29	51	78
130°	502. 448	○	○	BH BL	.039	.020	.19	.27	1.3	.35	.39	.48	.55	.61	20	20
	502. 548	○	○	BH BL	.071	.020	.35	.49	2.2	.59	.70	.86	.99	1.1	27	27
	502. 588	○	○	- BL	.039	.039	1.6	2.3	2.8	.87	.87	1.1	1.2	1.4	32	35
	502. 748	○	○	- BL	.079	.079	1.2	1.6	7.1	1.9	2.2	2.7	3.1	3.5	43	47
	502. 798	○	-	- BL	.099	.079	1.5	2.1	9.5	2.6	3.0	3.6	4.2	4.7	47	51
	502. 838	○	○	- BL	.118	.079	1.8	2.6	11.8	3.2	3.7	4.5	5.2	5.8	55	63
	502. 908	○	○	- BL	.158	.079	2.8	3.9	18.0	4.8	5.6	6.8	7.9	8.8	59	70
	503. 028	○	○	- BL	.158	.079	5.5	7.7	36	9.7	11.0	13.5	15.6	17.4	63	70
	503. 118	○	○	- BL	.236	.079	9.2	13.1	60	16.1	18.7	23	26	29	79	118

Example Type + Material no. + Conn. = Ordering no.
for ordering: 503. 028 + 17 + BL = 503. 028. 17. BL

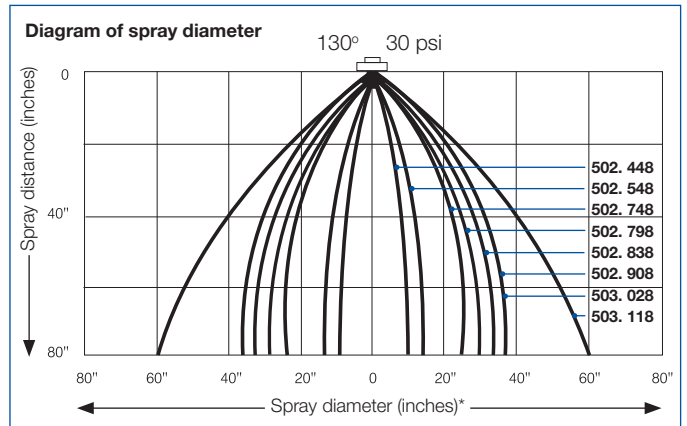
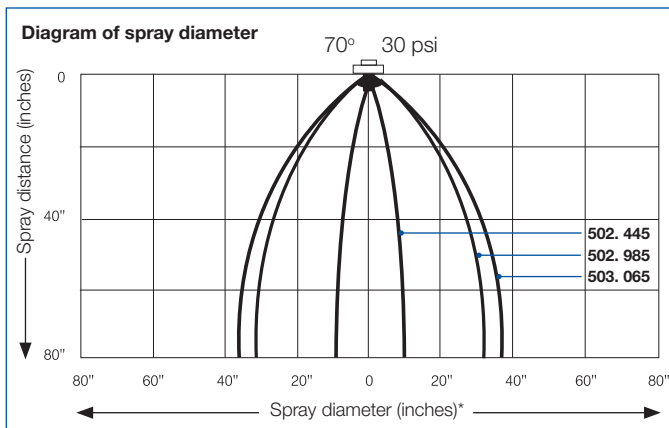

* Spray diameter coordinates represent distance from zero (0) coordinate. For each curve, add both coordinate values to obtain spray diameter.

Conversion formula for the above series: $\dot{V}_2 = \dot{V}_1 * \sqrt{\frac{P_2}{P_1}}$



Tongue-type deflector flat fan nozzles

Series 686



Deflector produces moderate impact with a very wide spray angle. Clog resistant. Even distribution.

Applications:

Foam control for storage tanks, wastewater treatment plants, dust suppression, light washing, spray cooling, degreasing and phosphating.

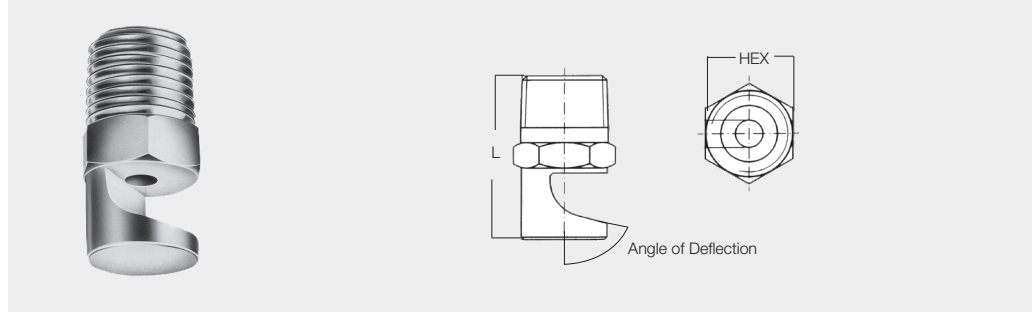

Dimensions (in.)			
Inlet (NPT)	L	HEX	Wt. (lb.)
1/8	.91	7/16	.03
1/4	1.10	9/16	.06
3/8	1.26	11/16	.09
1/2	1.58	7/8	.20

Spray angle	Deflector angle	Type	Ordering no.				Orifice diam. (in.)	Flow Rate (Gallons Per Minute)							Spray Width B (in.) @ 30 psi  H=10"				
			Material no.			Connection		10 psi	20 psi	liters per minute 2 bar	30 psi	40 psi	60 psi	80 psi		100 psi			
			316 SS 17	Brass 30	PVDF 5E	Male NPT													
					1/8"	1/4"	3/8"	1/2"											
90°	53°	686. 366	-	○	-	BA	-	-	-	.031	.10	.14	.63	.17	.20	.24	.28	.31	20
	75°	686. 406	-	○	-	BA	-	-	-	.039	.16	.22	1.0	.27	.31	.38	.44	.49	21
	40°	686. 686	-	○	-	-	BC	-	-	.094	.78	1.1	5.0	1.3	1.6	1.9	2.2	2.5	21
	40°	686. 726	-	○	-	BA	-	-	-	.106	.98	1.4	6.3	1.7	2.0	2.4	2.8	3.1	21
	40°	686. 806	-	○	-	-	BC	-	-	.133	1.6	2.2	10.0	2.7	3.1	3.8	4.4	4.9	21
	40°	686. 886	○	-	-	-	BC	-	-	.165	2.5	3.5	16.0	4.3	5.0	6.1	7.0	7.8	21
	40°	686. 926	○	-	-	-	-	BE	-	.185	3.1	4.4	20	5.4	6.2	7.6	8.8	9.8	21
140°	75°	686. 368	○	○	-	BA	-	-	-	.032	.10	.14	.63	.17	.20	.24	.28	.31	54
		686. 408	○	○	-	BA	-	-	-	.039	.16	.22	1.0	.27	.31	.38	.44	.49	54
		686. 448	○	○	-	BA	BC	-	-	.047	.19	.27	1.3	.35	.39	.48	.55	.61	54
		686. 488	○	○	-	BA	BC	-	-	.051	.25	.35	1.6	.43	.50	.61	.70	.78	54
		686. 528	○	○	-	BA	BC	-	-	.059	.31	.44	2.0	.54	.62	.76	.88	.98	54
		686. 568	○	○	○	BA	BC*	-	-	.067	.39	.55	2.5	.67	.78	.95	1.1	1.2	54
		686. 608	○	○	-	BA	BC	-	-	.075	.49	.69	3.2	.86	.98	1.2	1.4	1.5	54
		686. 648	○	○	-	-	BC	-	-	.087	.62	.88	4.0	1.1	1.2	1.5	1.8	2.0	54
		686. 688	○	○	-	BA	BC	-	-	.095	.78	1.1	5.0	1.4	1.6	1.9	2.2	2.5	54
		686. 728	-	○	-	BA	BC	-	-	.106	.98	1.4	6.3	1.7	2.0	2.4	2.8	3.1	54
		686. 768	○	○	-	BA*	BC	-	-	.118	1.2	1.8	8.0	2.2	2.5	3.0	3.5	3.9	54
		686. 808	○	○	-	BA	BC	-	-	.134	1.6	2.2	10.0	2.7	3.1	3.8	4.4	4.9	54
		686. 828	○	○	-	BA	BC	-	-	.142	1.7	2.5	11.2	3.0	3.5	4.3	4.9	5.5	54
		686. 848	○	○	-	BA*	BC	-	-	150	1.9	2.7	12.5	3.4	3.9	4.8	5.5	6.1	54
		686. 868	○	○	-	-	BC	-	-	.158	2.2	3.1	14.0	3.8	4.3	5.3	6.1	6.9	54
		686. 888	○	○	-	-	BC	-	-	165	2.5	3.5	16.0	4.3	5.0	6.1	7.0	7.8	54
		686. 908	○	○	-	-	BC	-	-	.177	2.8	3.9	18.0	4.8	5.6	6.8	7.9	8.8	54
686. 928	○	-	-	-	-	BE	-	.185	3.1	4.4	20	5.4	6.2	7.6	8.8	9.8	54		
686. 968	○	○	-	-	-	BE	BG	.209	3.9	5.5	25	6.7	7.8	9.5	11.0	12.3	54		
686. 988	○	○	-	-	-	BE	BG	.221	4.3	6.1	28	7.5	8.7	10.6	12.3	13.7	54		

* Only available in 316 SS (material no. 17)

Example Type + Material no. + Conn. = Ordering no.
for ordering: 686. 908 + 17 + BC = 686. 908. 17. BC



Deflector-plate nozzle Series 524 / 525

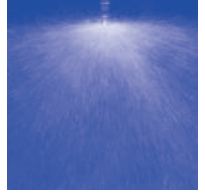

Full cone spray. Non clogging nozzle without swirl insert.

Applications:

Fire fighting and broadcast spraying, wide area spray.

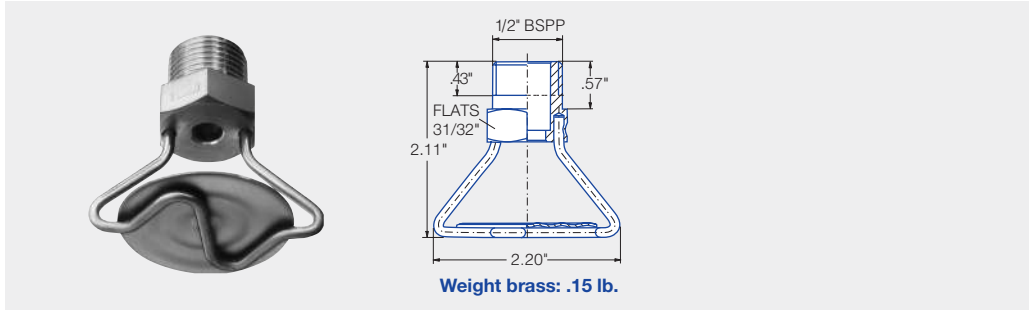

Spray angle	Ordering no.			Orifice diam. (in.)	Flow Rate (Gallons Per Minute)								Spray Diameter D (ft.) @ 45 psi	
	Type	Material no.			10 psi	20 psi	liters per minute	40 psi	60 psi	80 psi	100 psi	150 psi	Diagram	
		Connection: 1/2" Male BSPP	316 SS 17 ¹										Brass 30	H=40"
180°	524. 809	○	○	.158	1.6	2.2	10	3.1	3.8	4.4	4.9	6.0	18	21
	525. 049	○	○	.315	6.2	8.8	40	12.4	15.2	17.6	19.6	24	33	43
	525. 109	-	○	.366	8.8	12.5	57	17.7	22	25	28	34	33	44
	525. 169	-	○	.429	12.6	17.8	81	25	31	36	40	49	35	44
	525. 229	-	○	.481	17.4	25	112	35	43	49	55	67	22	34
	525. 269	○	○	.485	22	31	140	43	53	61	69	84	17	33

¹ We reserve the right to deliver 316 SS or 316TI SS under the material no. 17.

Version with dust protection cap on request.

Example	Type	+	Material-no.	=	Ordering no.
of ordering:	524.809	+	30	=	524.809.30

Conversion formula for the above series: $\dot{V}_2 = \dot{V}_1 * \sqrt{\frac{p_2}{p_1}}$



Rotating cleaning nozzle »MiniSpinner« Series 5MI

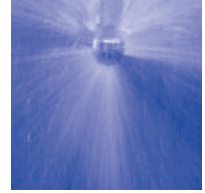

- Entirely made from stainless steel/Hastelloy
- Self-rotating
- Efficient slot design
- Modern double ball bearing

Max. tank diameter:
9 ft

Materials:
316L SS, 440C SS,
Hastelloy C22, Hastelloy C276

Max. temperature:
284 °F

Recommended operating pressure:
30 psi

Installation:
Operation in every direction is possible

Filtration:
Line strainer with a mesh size of 0.1 mm/170 mesh

Bearing:
Double ball bearing made of 440C SS
Double ball bearing made of C276

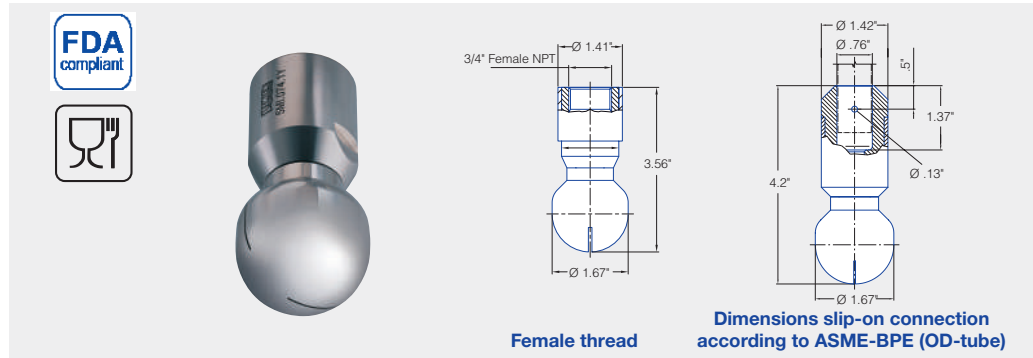

Spray angle	Ordering no.				Free Passage Ø (in.)	Flow Rate (Gallons Per Minute)					Max. tank diameter [ft]
	Type	Material no.	Connection			20 psi	30 psi	liters per minute 2 bar	40 psi	60 psi	
60°	5MC.022	316L SS 1Y	3/8" Female NPT	1/2" OD Slip-on	.04	5	6.2	23	7	8.6	-
	5MC.042	316L SS 1Y	3/8" Female NPT	1/2" OD Slip-on	.118	8.8	10.8	40	12.4	15.2	-
90°	5MC.004	316L SS 1Y	3/8" Female NPT	1/2" OD Slip-on	.031	7.0	8.6	32	9.9	12.2	6
120°	5MC.069	316L SS 1Y	3/8" Female NPT	1/2" OD Slip-on	.035	5.5	6.7	25	8	10	5.6
	5MC.049	316L SS 1Y	3/8" Female NPT	1/2" OD Slip-on	.035	8.6	10.5	39	12.1	14.8	6

Example for ordering: 5MI. 162. 1Y. + BH = 5MI. 162. 1Y. BH

Please note: The nozzles with a slip-on connection type fitting may have a higher flow rate than listed due to the self-flushing design around the customer's tube which is inserted into the nozzle socket. We do not recommend operation of these products with compressed air, steam, or gases. To protect the products' inner workings, we suggest use of a line strainer with a 170 mesh size.

Bearing:
Double ball bearing

Filtration:
Line strainer with 170 mesh size



ATEX version on request

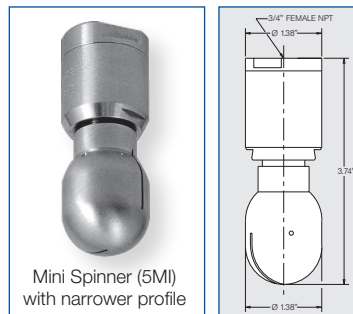

Mini Spinner (5MI) with narrower profile

Spray angle	Ordering no.		Free Passage (in.)	Flow Rate (Gallons Per Minute)					Max. tank diameter [ft]
	Type	Conn. 3/4" Female NPT		20 psi	30 psi	liters per minute 2 bar	40 psi	60 psi	
360°	5MI.089.17	BL	.038	11	13.2	49	15	19	6
	5MI.139.17	BL	.059	15	18.5	69	21	26	7



Rotating cleaning nozzle »Teflon® Whirly« Series 573 / 583

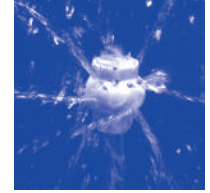

- Self rotating
- Rotating solid jets
- Recommended for tanks made of glass and enamel
- 3A® version available

Max tank diameter:
11 ft

Materials:
PTFE (Teflon®)

Max. temperature:
203 °F
(Versions for use with higher temperature (398 °F) on request)

Recommended operating pressure:
30 psi

Installation:
Operation in every direction is possible

Filtration:
Line strainer with a mesh size of 0.3 mm/50 mesh

Bearing:
Slide bearing made of PTFE

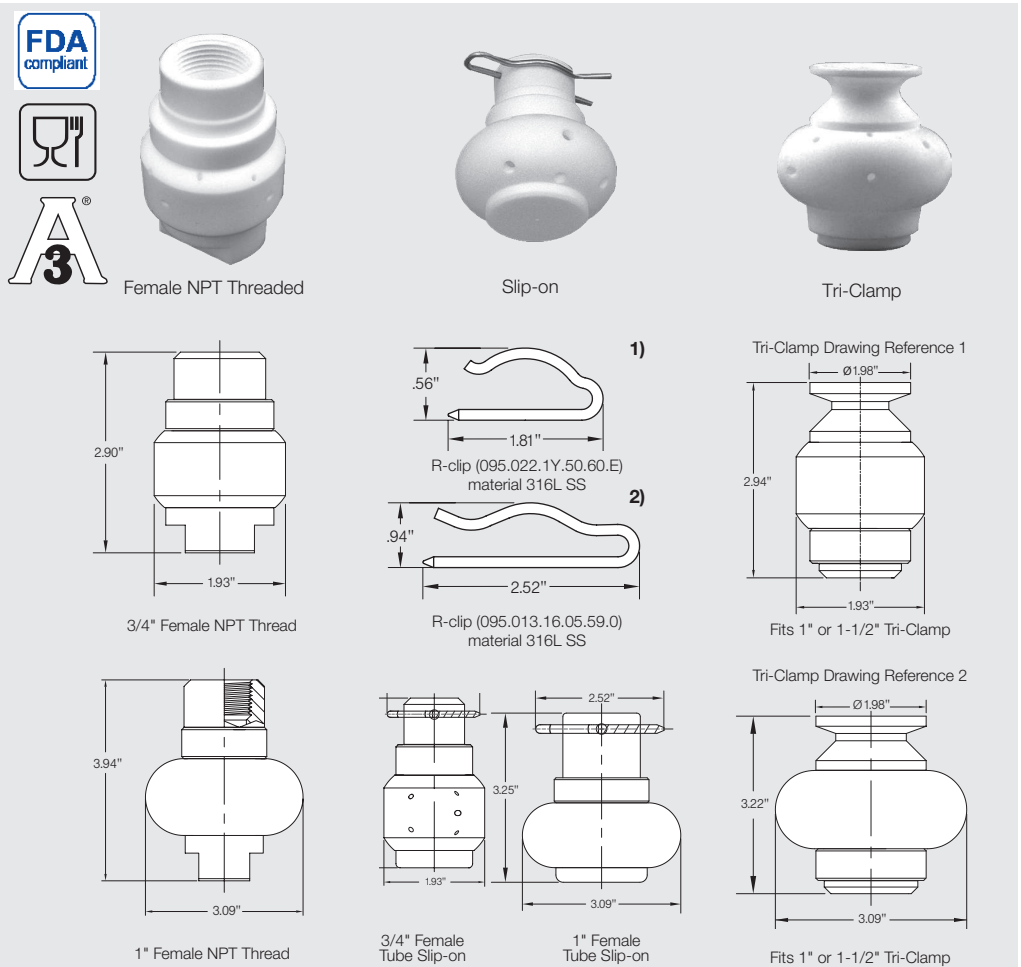

Please note: We do not recommend operation of these products with compressed air, steam, or gases. To protect the products' inner workings, we suggest use of a line strainer with a 50 mesh size. For further information, please contact your representative or Lechler.

The nozzles with a slip-on connection type fitting may have a higher flow rate than listed due to the self-flushing design around the customer's tube which is inserted into the nozzle socket.

Spray angle	R-clip	Ordering no.						Free Passage (in.)	Flow Rate (Gallons Per Minute)						Dimensions for female thread version		Max. tank diameter [ft]
		Type	Connection						20 psi	30 psi	liters per minute 40 psi 2 bar	60 psi	Height H [in]	Diameter D [in]			
			3/4" Female NPT	1" Female NPT	3/4" Slip-on	1" Slip-on	1 1/2" Tri-Clamp										
270°	1)	583. 116. 55	BL	-	TF07*	-	15	.094	15	18	67	21	26	2.91	1.93	8.2	
	1)	583. 266. 55	BL	-	TF07*	-	15	.133	32	39	145	45	55	2.91	1.93	9.2	
	1)	573. 266. 55	BL	-	TF07*	-	15	.133	32	39	145	45	55	2.91	1.93	9.2	
360°	1)	583. 119. 55	BL	-	TF07*	-	15	.071	13	16	58	18	22	2.91	1.93	7.9	
	1)	583. 209. 55	BL	-	TF07*	-	15	.138	22	27	100	31	38	2.91	1.93	8.2	
	1)	583. 269. 55	BL	-	TF07*	-	15	.189	32	39	145	45	55	2.91	1.93	9.2	
	2)	583. 279. 55	-	BN	-	TF10*	15	.146	33	40	150	47	57	3.94	3.09	9.8	
	2)	583. 349. 55	-	BN	-	TF10*	15	.220	50	61	226	70	86	3.94	3.09	10.5	

Example Type + Conn. = Ordering no.
for ordering: 583. 266. 55. + BL = 583. 266. 55. BL

* The slip-on version has been authorized to use the 3-A® Symbol by the 3-A® Sanitary Symbol Council Administrative Council for Spray Cleaning Devices (78-01).

** Contact Lechler for maximum ambient temperature.



Rotating cleaning nozzle »Teflon® Hi Temp Whirly« Series 599

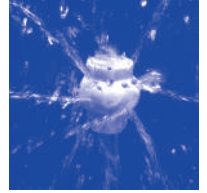

- Self rotating
- Rotating solid jets
- Recommended for tanks made of glass and enamel
- Withstands high temperatures

Max. tank diameter:
8.2 ft

Materials:
PTFE (Teflon®)

Max. temperature:
274 °F



Recommended operating pressure:
30 psi

Installation:
Operation in every direction is possible

Filtration:
Line strainer with a mesh size of 0.3 mm/50 mesh

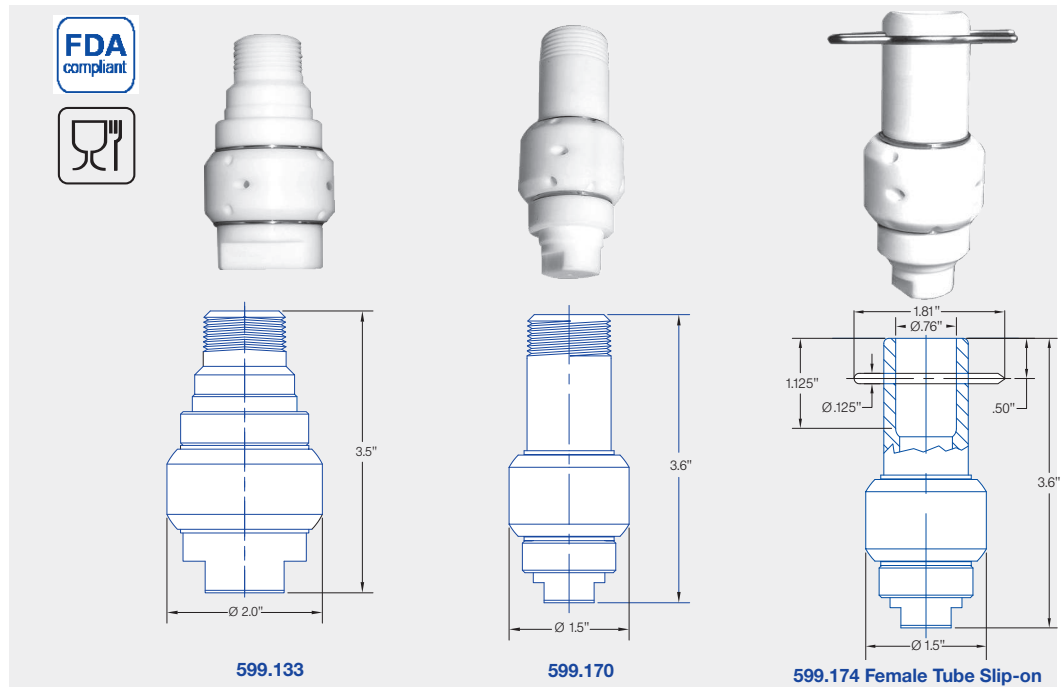
Bearing:
Slide bearing made of PTFE



Spray angle 	Ordering no.	Connection		Flow Rate (Gallons Per Minute)					Max. tank diameter [ft]
		3/4" Male NPT	3/4" OD Female Slip-on	20 psi	30 psi	liters per minute 2 bar	40 psi	60 psi	
360° 	599. 133. 55	BK	-	22	27	100	31	38	8.2
	599. 170. 55	BK	-	19	23	84	26	32	8
	599. 174. J7	-	TF07	19	23	84	26	32	8

Please note: We do not recommend operation of these products with compressed air or gases. However, these products have been shown to be suitable for spraying low pressure steam (refer to **Applications** above). To protect the products' inner workings when spraying liquid, we suggest use of a line strainer with a 50 mesh size. For further information, please contact your representative or Lechler.

The nozzles with a slip-on connection type fitting may have a higher flow rate than listed due to the self-flushing design around the customer's tube which is inserted into the nozzle socket.

Example **Type** + **Conn.** = **Ordering no.**
for ordering: 599. 170. 55. + BK = 599. 170. 55. BK

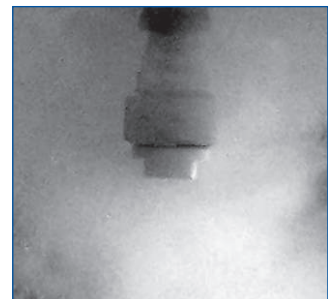
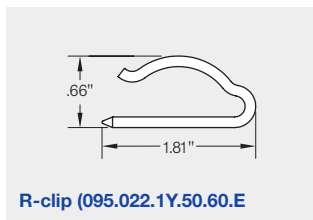

PTFE Whirly spraying steam

Hastelloy® is a registered trademark of Haynes International Inc.



Rotating cleaning nozzle "Whirly 2.0" Series 5W9

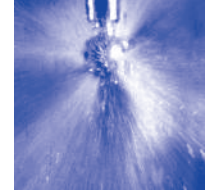

- Popular and proven design
- Powerful flat jets
- Wide range of flow rates

Recommended operating pressure:
30 psi

Max. fluid temperature:
284°F

Material:
Stainless steel 316L SS
PEEK

Bearing:
Double ball bearing

Installation:
Operates in every direction

Filtration:
Line strainer with a mesh size of 0.1 mm/170 mesh size

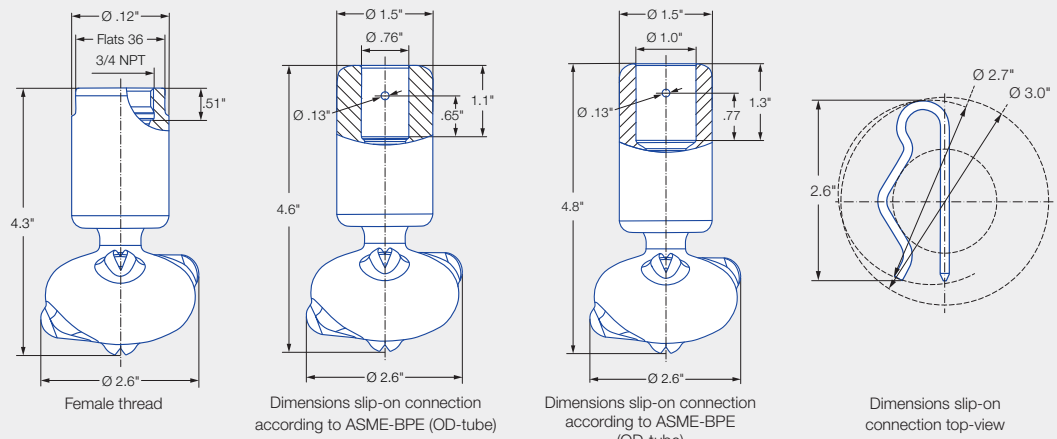

ATEX version on request

Spray angle	Type	Ordering no.			Free Passage Ø (in.)	V̇ water [gal/min]					Max. tank diameter [ft]
		Connection				p [psi] (p _{max} = 87 psi)					
		3/4 NPT	3/4"- Slip-on connection	1" Slip-on connection		20 psi	30 psi	2 bar	40 psi	60 psi	
270°	5W9.075.1Y	BL	TF07	TF10	.79	10.6	12.9	48	15	18.3	5.9
	5W9.145.1Y	BL	TF07	TF10	.11	15.6	19.1	71	22	27.0	6.9
	5W9.195.1Y	BL	TF07	TF10	.13	21.3	26.1	97	30	36.9	8.5
270°	5W9.076.1Y	BL	TF07	TF10	.79	10.6	12.9	48	15	18.3	5.9
	5W9.106.1Y	BL	TF07	TF10	1.0	12.8	15.6	58	18	22.0	6.9
	5W9.196.1Y	BL	TF07	TF10	1.3	21.3	26.1	97	30	36.9	8.5
360°	5W9.079.1Y	BL	TF07	TF10	.06	10.6	12.9	48	15	18.3	5.9
	5W9.149.1Y	BL	TF07	TF10	.09	15.6	19.1	71	22	27.0	6.9
	5W9.199.1Y	BL	TF07	TF10	.12	21.3	26.1	97	30	36.9	8.5
	5W9.279.1Y	BL	TF07	TF10	.20	31.9	39.1	145	45	55.2	9.8

The maximum tank diameter shown above applies for the recommended operating pressure and is indicative only. The cleaning result is also affected by the type of soiling.

Operation with compressed air only for short-term usage. Operation above the recommended operating pressure means higher wear and smaller droplets. This might have adverse effects on the cleaning result.

Slip-on information: - R-clip made of stainless steel 316L SS is included(Ordering no.: 095.022.1Y.50.60.E).
- Depending on diameter of the adapter the flow rate can increase due to leakage between connecting pipe and rotating cleaning nozzle.

Example	Type	+	Conn.	=	Ordering no.
for ordering:	569.055.1Y.	+	BL	=	569.055.1Y.BL



Rotating cleaning nozzle »Gyro« Series 577

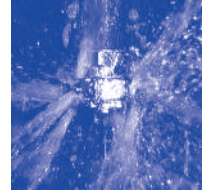

- Self rotating
- Effective flat jet nozzles
- Large free cross sections, less prone to clogging

Max. tank diameter:
40 ft

Materials:
316L SS, PTFE

Max. temperature:
194 °F

Recommended operating pressure:
40 psi

Installation:
Vertically facing downward

Filtration:
Line strainer with a mesh size of 0.3 mm/50 mesh

Bearing:
Slide bearing made of PTFE

Accessories:
Spare parts set consisting of: top seal, bottom seal, bolt, nut, sleeve, instructions for use

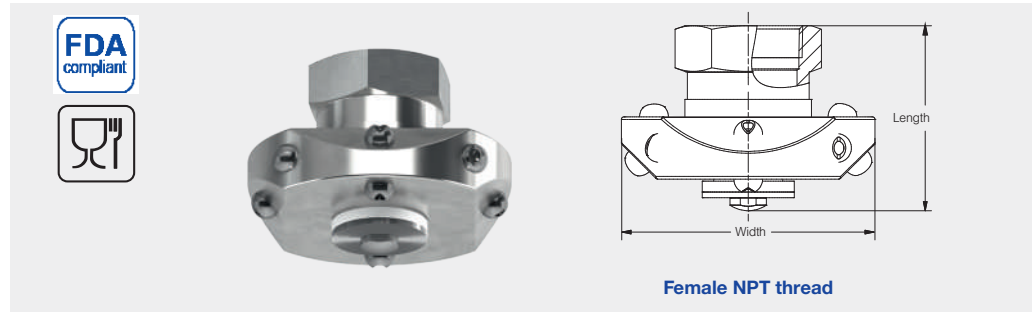

Spray angle	Ordering no.			Flow Rate (Gallons Per Minute)				Dimensions	
	Type	Connection		20 psi	liters per minute 2 bar	40 psi	60 psi	Length (in.)	Width (in.)
		1" NPT	2" NPT						
180° 	577. 283. 1Y	BN	-	36	163	51	62	2.8	4.6
	577. 363. 1Y	BN	-	57	258	80	98	2.8	4.6
	577. 403. 1Y	-	BW	71	322	100	122	4.1	6.1
	577. 433. 1Y	-	BW	85	386	120	147	4.1	6.1
	577. 523. 1Y	-	BW	140	639	199	243	4.1	6.1
180° 	577. 284. 1Y	BN	-	36	161	51	62	2.8	4.6
	577. 364. 1Y	BN	-	57	258	80	98	2.8	4.6
	577. 404. 1Y	-	BW	71	322	100	122	4.1	6.1
	577. 434. 1Y	-	BW	85	386	120	147	4.1	6.1
	577. 494. 1Y	-	BW	145	538	167	205	4.1	6.1
270° 	577. 285. 1Y	BN	-	36	161	51	62	2.8	4.6
	577. 365. 1Y	BN	-	57	258	80	98	2.8	4.6
	577. 405. 1Y	-	BW	71	322	100	122	4.1	6.1
	577. 435. 1Y	-	BW	85	386	120	147	4.1	6.1
	577. 495. 1Y	-	BW	145	538	167	205	4.1	6.1
360° 	577. 289. 1Y	BN	-	36	161	51	62	2.8	4.6
	577. 369. 1Y	BN	-	57	258	80	98	2.8	4.6
	577. 409. 1Y	-	BW	71	322	100	122	4.1	6.1
	577. 439. 1Y	-	BW	85	386	120	147	4.1	6.1
	577. 499. 1Y	-	BW	145	538	167	205	4.1	6.1

The PTFE bearings and other wear parts can be replaced easily to extend the life of the unit. A rebuild kit contains: Bearing sleeves, bolt, nut, spacer, and complete instructions.

Please note: We do not recommend operation of these products with compressed air, steam, or gases. For further information, please contact Lechler.

Example **Type** + **Conn.** = **Ordering no.**
for ordering: 577. 434. 1Y + BW = 577. 434. 1Y. BW

* Contact Lechler for maximum ambient temperature.

Size **Product code**
1" 057.701.55.000
2" 057.702.55.000

Contents of Gyro rebuild kit





Rotating cleaning nozzle »XactClean® HP« Series 5S2 / 5S3



- Controlled rotation
- Powerful flat jet nozzles
- Very efficient tank cleaning nozzle

Max. tank diameter:
26 ft

Materials:
316L SS, 316 SS, 632 SS,
PEEK, PTFE,
Zirconium oxide, EPDM

Max. temperature:
203°F

Recommended operating pressure:
75 psi

Installation:
Operation in every direction is possible

Filtration:
Line strainer with a mesh size of 0.3 mm/50 mesh

Bearing:
Double ball bearing

Rotation monitoring sensor:
Sensor compatible, please ask for more information.

Operation with compressed air only for short-term usage. Operation above the recommended operating pressure means higher wear and smaller drop-lets. This might have adverse effects on the cleaning result.

Slip-on information:
- R-clip made of stainless steel 316L SS is included (Ordering number: 095.022.1Y.50.60.E (TF07), 095.013.1E.05.59.0 (TF05)).
- Depending on diameter of the adapter the flow rate can increase due to leakage between connecting pipe and rotating cleaning nozzle.

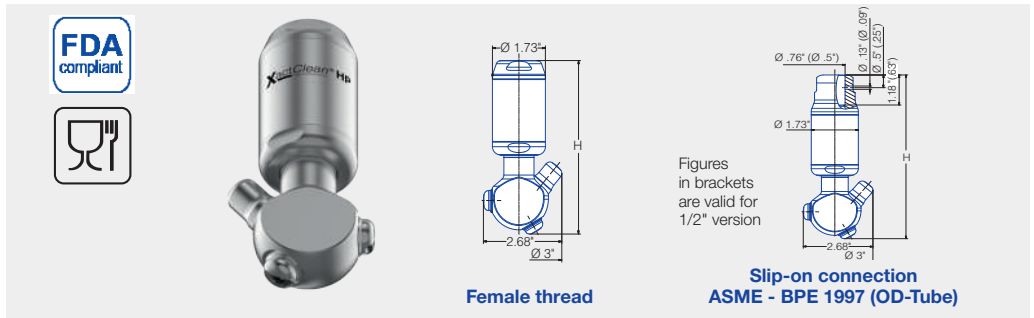

Nozzle dimensions [in]

Connection	Max. Height H [in]
BF	5.83
BH	5.87
BL	5.47
BN	5.47
TF05	5.91
TF07	6.46



ATEX version on request

Spray angle	Type	Ordering no.						Free Passage Ø (in.)	Flow Rate (Gallons Per Minute)					Max. tank diameter [ft]
		Connection							2 bar	30 psi	40 psi	75 psi	145 psi	
		3/8" Female NPT	1/2" Female NPT	3/4" Female NPT	1" Female NPT	1/2" OD Slip-on	3/4" OD Slip-on							
180°	5S2.953.1Y	BF	BH	-	-	TF05	-	.08	25	6.6	7.8	10.6	15.1	11.5
	5S3.053.1Y	-	BH	-	-	TF05	-	.08	41	10.8	12.8	17.2	24.3	13
	5S3.113.1Y	-	BH	BL	-	-	TF07	.08	60	15.9	18.4	24.8	35.1	20
	5S3.183.1Y	-	-	BL	-	-	TF07	.08	89	23.5	27.7	37.3	52.6	23
	5S3.233.1Y	-	-	BL	-	-	TF07	.08	111	29.3	34.3	46.2	65.5	25
	5S3.263.1Y	-	-	BL	BN	-	TF07	.08	135	35.7	41.8	56.3	79.5	26
180°	5S2.954.1Y	BF	BH	-	-	TF05	-	.08	25	6.6	7.8	10.6	15.1	11.5
	5S3.054.1Y	-	BH	-	-	TF05	-	.08	41	10.8	12.8	17.2	24.3	13
	5S3.114.1Y	-	BH	BL	-	-	TF07	.08	60	15.9	18.4	24.8	35.1	20
	5S3.184.1Y	-	-	BL	-	-	TF07	.08	89	23.5	27.7	37.3	52.6	23
	5S3.234.1Y	-	-	BL	-	-	TF07	.08	111	29.3	34.3	46.2	65.5	25
	5S3.264.1Y	-	-	BL	BN	-	TF07	.08	135	35.7	41.8	56.3	79.5	26
270°	5S2.955.1Y	BF	BH	-	-	TF05	-	.08	25	6.6	7.8	10.6	15.1	11.5
	5S3.055.1Y	-	BH	-	-	TF05	-	.08	41	10.8	12.8	17.2	24.3	13
	5S3.115.1Y	-	BH	BL	-	-	TF07	.08	60	15.9	18.4	24.8	35.1	20
	5S3.185.1Y	-	-	BL	-	-	TF07	.08	89	23.5	27.7	37.3	52.6	23
	5S3.235.1Y	-	-	BL	-	-	TF07	.08	111	29.3	34.3	46.2	65.5	25
	5S3.265.1Y	-	-	BL	BN	-	TF07	.08	135	35.7	41.8	56.3	79.5	26
270°	5S2.956.1Y	BF	BH	-	-	TF05	-	.08	25	6.6	7.8	10.6	15.1	11.5
	5S3.056.1Y	-	BH	-	-	TF05	-	.08	41	10.8	12.8	17.2	24.3	13
	5S3.116.1Y	-	BH	BL	-	-	TF07	.08	60	15.9	18.4	24.8	35.1	20
	5S3.186.1Y	-	-	BL	-	-	TF07	.08	89	23.5	27.7	37.3	52.6	23
	5S3.236.1Y	-	-	BL	-	-	TF07	.08	111	29.3	34.3	46.2	65.5	25
	5S3.266.1Y	-	-	BL	BN	-	TF07	.08	135	35.7	41.8	56.3	79.5	26
360°	5S2.959.1Y	BF	BH	-	-	TF05	-	.07	25	6.6	7.8	10.6	15.1	11.5
	5S3.059.1Y	-	BH	-	-	TF05	-	.08	41	10.8	12.8	17.2	24.3	13
	5S3.119.1Y	-	BH	BL	-	-	TF07	.08	60	15.9	18.4	24.8	35.1	20
	5S3.189.1Y	-	-	BL	-	-	TF07	.08	89	23.5	27.7	37.3	52.6	23
	5S3.239.1Y	-	-	BL	-	-	TF07	.08	111	29.3	34.3	46.2	65.5	25
	5S3.269.1Y	-	-	BL	BN	-	TF07	.08	135	35.7	41.8	56.3	79.5	26



Rotating cleaning nozzle »XactClean® HP 2« Series 5S6 / 5S7



Features:

- Flat fan nozzle with high impact
- Uniform cleaning
- High efficiency due to controlled rotation
- High operating reliability thanks to robust drive unit



Series 5S6/5S7

Technical data:

Maximum operating temperature 150 °C	Maximum ambient temperature 150 °C	Installation Operation in every installation position	Bearing Double ball bearing
Material Stainless steel 1.4404 (316L), PEEK, EPDM	Weight 650–900 g	Surface quality Ra ≤ 0.8 µm <small>OUTSIDE</small>	Surface quality Ra ≤ 1.6 µm <small>INSIDE</small>
Steam suitability Suitable	Insertion diameter 50–79 mm	Recommended filter Line strainer with a mesh size of 0.3 mm/50 mesh	Recommended operating pressure 3 bar
Rotation monitoring Sensor-compatible, information: see pages 96–97	Maintainable	Adapter 3/8 BSPP, 1/2 BSPP, 3/4 BSPP and 1 BSPP are compatible with HygienicFit	

Max. tank diameter
The specified maximum tank diameter applies to the recommended operating pressure and is indicative only. The type of soiling is also decisive for the cleaning result.

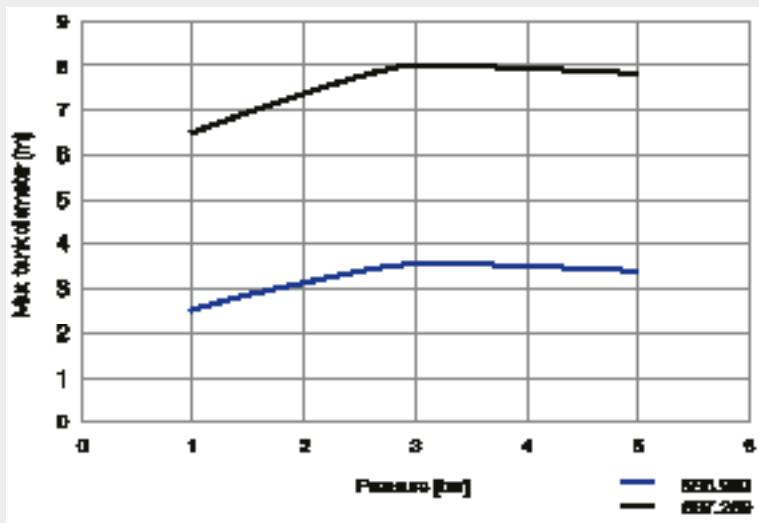

Overview of maximum tank diameter depending on pressure





Rotating cleaning nozzle »XactClean® HP 2« Series 5S6 / 5S7

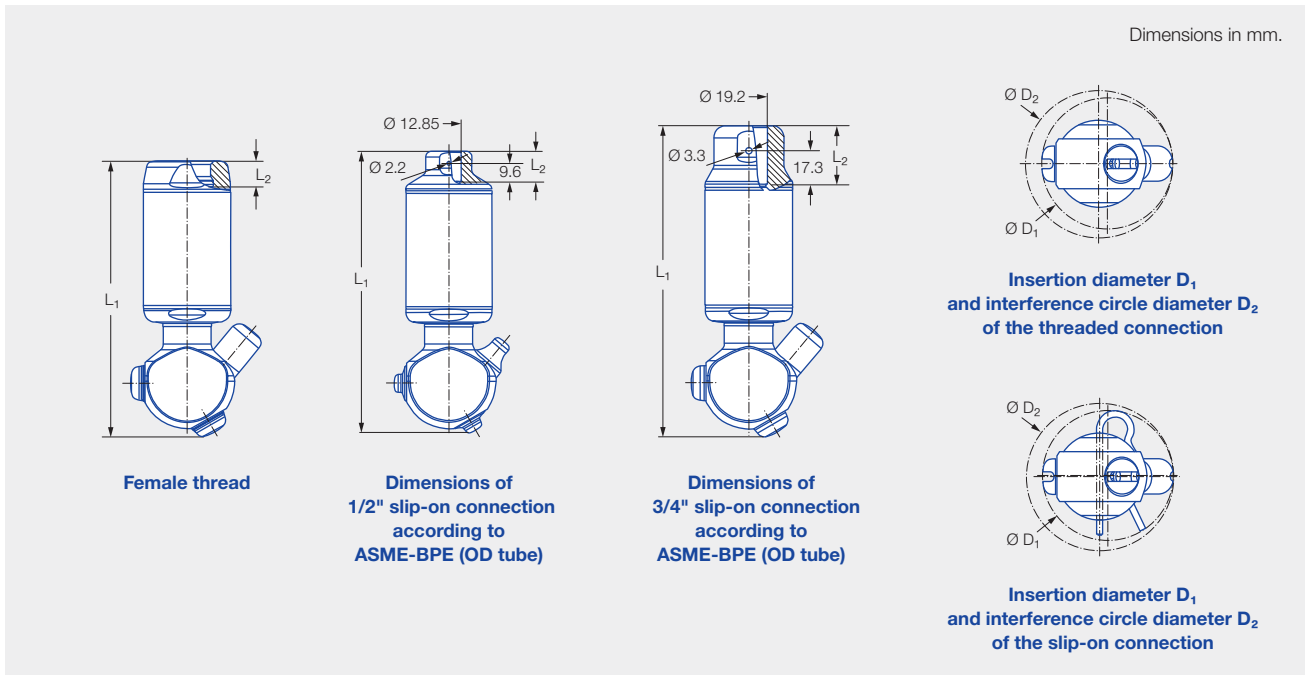

Connection		Dimensions [mm]			
		L_1	L_2	Insertion diameter D_1	Interference circle diameter D_2
AF	3/8 BSPP	141.0	9.0	50.0–66.0	50.0–67.0
AH	1/2 BSPP	143.0	13.0	50.0–74.0	50.0–76.0
AL	3/4 BSPP	143.0	13.2	50.0–79.0	50.0–81.0
AN	1 BSPP	140.0	16.5	51.0–79.0	53.0–80.0
TF05	1/2" slip-on connection	150.0	16.0	52.0–66.0	50.0–67.0
TF07	3/4" slip-on connection	160.0	30.0	66.0–79.0	50.0–81.0

Spray angle	Type	Order no. Connection						Narrowest cross-section \varnothing [mm]	\dot{V} water [l/min]				Max. tank diameter [m]
		3/8 BSPP	1/2 BSPP	3/4 BSPP	1 BSPP	1/2" slip-on connection	3/4" slip-on connection		p [bar] ($p_{max} = 15$ bar)				
									2.0	3.0	5.0	10.0	
180° 	5S6.963.1Y	AF	AH			TF05	1.7	25	31	40	57	1.9	3.5
	5S7.043.1Y		AH			TF07	2.0	41	50	65	92	3.0	4.0
	5S7.113.1Y		AH	AL		TF07	2.0	60	73	94	133	4.4	6.0
	5S7.183.1Y			AL		TF07	2.0	89	109	141	199	6.5	7.0
	5S7.223.1Y			AL		TF07	2.0	111	136	175	248	8.2	7.5
	5S7.253.1Y			AL	AN	TF07	2.0	135	165	213	301	9.9	8.0
180° 	5S6.964.1Y	AF	AH			TF05	1.7	25	31	40	57	1.9	3.5
	5S7.044.1Y		AH			TF07	2.0	41	50	65	92	3.0	4.0
	5S7.114.1Y		AH	AL		TF07	2.0	60	73	94	133	4.4	6.0
	5S7.184.1Y			AL		TF07	2.0	89	109	141	199	6.5	7.0
	5S7.224.1Y			AL		TF07	2.0	111	136	175	248	8.2	7.5
	5S7.254.1Y			AL	AN	TF07	2.0	135	165	213	301	9.9	8.0





Rotating cleaning nozzle »XactClean® HP 2« Series 5S6 / 5S7



Spray angle	Order no.							Narrowest cross-section Ø [mm]	V̇ water [l/min]				Max. tank diameter [m]	
	Type	Connection							p [bar] (p _{max} = 15 bar)					
		3/8 BSPP	1/2 BSPP	3/4 BSPP	1 BSPP	1/2" slip-on connection	3/4" slip-on connection		2.0	3.0	5.0	10.0		at 5 bar [m³/h]
270° 	5S6.965.1Y	AF	AH			TF05		1.7	25	31	40	57	1.9	3.5
	5S7.045.1Y		AH				TF07	2.0	41	50	65	92	3.0	4.0
	5S7.115.1Y		AH	AL			TF07	2.0	60	73	94	133	4.4	6.0
	5S7.185.1Y			AL			TF07	2.0	89	109	141	199	6.5	7.0
	5S7.225.1Y			AL			TF07	2.0	111	136	175	248	8.2	7.5
	5S7.255.1Y			AL	AN		TF07	2.0	135	165	213	301	9.9	8.0
270° 	5S6.966.1Y	AF	AH			TF05		1.7	25	31	40	57	1.9	3.5
	5S7.046.1Y		AH				TF07	2.0	41	50	65	92	3.0	4.0
	5S7.116.1Y		AH	AL			TF07	2.0	60	73	94	133	4.4	6.0
	5S7.186.1Y			AL			TF07	2.0	89	109	141	199	6.5	7.0
	5S7.226.1Y			AL			TF07	2.0	111	136	175	248	8.2	7.5
	5S7.256.1Y			AL	AN		TF07	2.0	135	165	213	301	9.9	8.0
360° 	5S6.969.1Y	AF	AH			TF05		1.5	25	31	40	57	1.9	3.5
	5S7.049.1Y		AH				TF07	2.0	41	50	65	92	3.0	4.0
	5S7.119.1Y		AH	AL			TF07	2.0	60	73	94	133	4.4	6.0
	5S7.189.1Y			AL			TF07	2.0	89	109	141	199	6.5	7.0
	5S7.229.1Y			AL			TF07	2.0	111	136	175	248	8.2	7.5
	5S7.259.1Y			AL	AN		TF07	2.0	135	165	213	301	9.9	8.0

NPT threads on request.

Information on operation

Compressed air can be used only for a short time for blowing dry. Use above the recommended pressure will have a negative effect on the cleaning result and wear.

Information on slip-on connection

- Cotter pin made of stainless steel 316L included (Order no. 095.022.1Y.50.60.E [TF07], 095.013.1E.05.59 [TF05]).
- Depending on the adapter diameter, the flow rate may increase due to the leakage between the adapter and rotating cleaning nozzle.

Ordering example with FDA and (EC) 1935/2004 conformity.

All materials are suitable for contact with food.



Type + Connection = Order no.
5S6.965.1Y + AF = 5S6.965.1Y.AF

Ordering example with ATEX approval, FDA and (EC) 1935/2004 conformity.

Unit group/Category/Zones:

- Ex II 1G Ex h IIB T6...T3 Ga
- Ex II 1D Ex h IIIC T85 °C...T190 °C Da

Important

The code for the connection changes for the ATEX version with slip-on connection.
Ordering example for 1/2" slip-on connection:
5S6.963.1Y.T1.EX
Ordering example for 3/4" slip-on connection:
5S7.043.1Y.T2.EX



Type + Connection + ATEX = Order no.
5S6.965.1Y + AF + EX = 5S6.965.1Y.AF.EX



High impact tank cleaning machine

Series 5T2/ 5T3/ 5TB

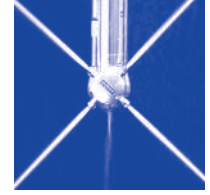

- Gear-controlled
- Particularly powerful solid jets
- Operating pressures up to 217 and 362 psi possible

Max. tank diameter:

5T2/5T3 - 43 ft
5TB - 49 ft

Materials:

AISI 316 L, AISI 632, PTFE, PEEK, Zirconium oxide, EPDM, 32 RA surface finish is included with every material

Max. temperature:

5T2/5T3 302°F
5TB: 203°F

Recommended operating pressure:

75 psi, max.

Installation:

Operation in every direction possible

Filtration:

Line strainer with a mesh size of 0.2 mm/80 mesh

Bearing:

Ball bearing

Weight:

5T2/5T3 approx. 2.2 lb.
5TB approx. 8.8 lb.

Rotation monitoring sensor:

Sensor compatible, please ask for more information.



ATEX version on request

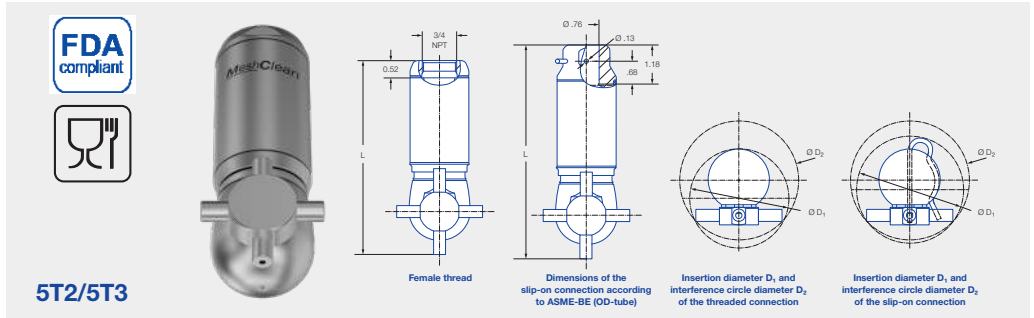

Spray angle	Ordering no.			Flow Rate (Gallons Per Minute)				Dimensions [in]						Max. tank diameter [ft]
	Type	Code		p [psi] (p _{max} = 218 psi)				Female thread			Slip-on connection			
		3/4" NPT	3/4"-Slip-on connection	30	75	5.0	at 75 psi [SCFM]	L	Ø D ₁	Ø D ₂	L	Ø D ₁	Ø D ₂	
360°	5T2.849.1Y	BL	TF07	3.43	0.79	20	0.7	5.59	2.68	3.23	6.18	3.03	3.23	37.7
	5T2.969.1Y	BL	TF07	6.60	1.57	40	1.4	5.59	2.68	3.23	6.18	3.03	3.23	39.4
	5T3.029.1Y	BL	TF07	9.25	2.17	55	1.9	5.59	2.68	3.23	6.18	3.03	3.23	41.0
	5T3.089.1Y	BL	TF07	13.21	3.11	79	2.8	5.83	2.91	3.58	6.42	3.23	3.58	42.7

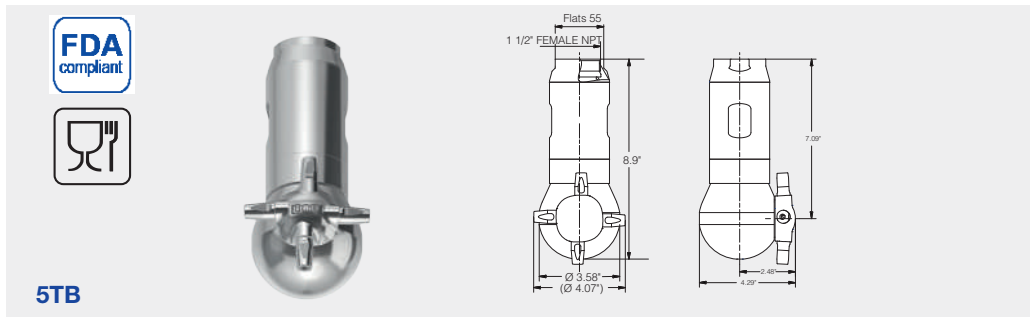

Spray Angle	Ordering no.	Free Passage (in.)	Number, Ø of nozzles (mm)	Flow Rate (Gallons Per Minute)					Max. tank Ø (ft.)	Max. pressure (psi)
				liters per minute	2 bar	30 psi	40 psi	75 psi		
360°	5TB. 406. 1Y. BS	.236	4 x 6.0 mm	107	29	33	45	63	46	362
	5TB. 407. 1Y. BS	.236	4 x 7.0 mm	132	35	41	56	78	46	362
	5TB. 408. 1Y. BS	.236	4 x 8.0 mm	150	40	47	64	89	49	362



High impact tank cleaning machine Series 5TM



- Gear driven
- Very powerful solid jets
- Popular and proven design

Max. tank diameter:
79 ft

Materials:
316L, 304 SS, 302 SS,
PTFE, PEEK

Max. temperature:
5TM: 203°F/95°C

**Recommended
operating pressure:**
75 psi

Installation:
Operation in every direction
possible

Filtration:
Line strainer with a mesh size
of 0.2 mm/80 Mesh

Bearing:
Ball bearing and slide bearings

Weight: Approx. 16.5 lb.

**Rotation monitoring
sensor:**
Sensor compatible, please
ask for more information.



Our special mounting bracket provides
the ability for the 5TM to reach the
far ends of long horizontal tanks/
tankers. Mounting bracket part number:
099.164.17.00.0

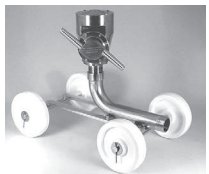

Portable cart for easier transporting of
your 5TM from tank to tank. The cart part
number is **M20.000.17.BR**. For use
with "BR" connection only.

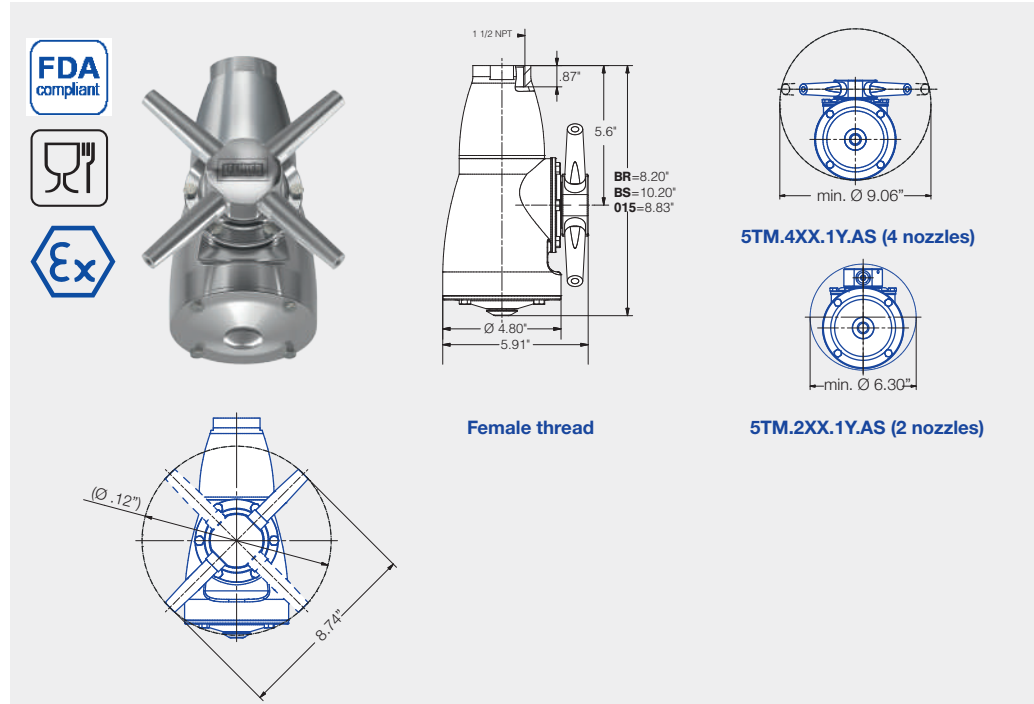

Ordering no.				Free Passage (in.)	No. of Nozzles x Diameter		Operating Pressure				Max. tank diameter [ft]
Type	Connection						40 psi	60 psi	80 psi	100 psi	
	1 1/2" Male NPT	1 1/2" Female NPT	1 1/2" CL150 Flange								
5TM. 208. 1Y	BR	BS	O15	.314	2 x 8mm	Flow Rate	39 gpm	48 gpm	55 gpm	61 gpm	79
5TM. 209. 1Y	BR	BS	O15	.354	2 x 9mm	Flow Rate	45 gpm	54 gpm	60 gpm	65 gpm	79
5TM. 210. 1Y	BR	BS	O15	.394	2 x 10mm	Flow Rate	50 gpm	61 gpm	70 gpm	79 gpm	79
5TM. 211. 1Y	BR	BS	O15	.433	2 x 11mm	Flow Rate	57 gpm	68 gpm	78 gpm	80 gpm	75
5TM. 406. 1Y	BR	BS	O15	.236	4 x 6mm	Flow Rate	43 gpm	53 gpm	61 gpm	69 gpm	59
5TM. 407. 1Y	BR	BS	O15	.276	4 x 7mm	Flow Rate	53 gpm	65 gpm	75 gpm	83 gpm	66
5TM. 408. 1Y	BR	BS	O15	.315	4 x 8mm	Flow Rate	62 gpm	76 gpm	88 gpm	98 gpm	72
5TM. 409. 1Y	BR	BS	O15	.354	4 x 9mm	Flow Rate	74 gpm	88 gpm	98 gpm	106 gpm	75
5TM. 410. 1Y	BR	BS	O15	.394	4 x 10mm	Flow Rate	81 gpm	99 gpm	114 gpm	128 gpm	75

ATEX available upon request

Example Type + Conn. = Ordering no.
for ordering: 5TM. 208. 17 + BR = 5TM. 208. 17. BR

QUALITY WITH A SYSTEM

Lechler products are used in a wide variety of sectors and applications. Which is why the products' requirements are often very specific to certain applications. We define the term "quality" as the extent to which our products fulfill our customer's individual requirements.

In order to do this we have been certified to internationally renowned certificates.

Certifications and Quality

- ISO 9001-2008 Certification
- DIN EN 10204 Inspection Certificate
- Classification according to Pressure Equipment Directive 2014/68/EU
- Declaration of Incorporation of partly completed machinery according to 2006/42/EC
- Declaration of Conformity of machinery according to 2006/42/EC
- ASME qualified welding procedure specifications
- Welding procedure specification DIN EN ISO 15609

Code Compliance

- ASME B31.1 Power Piping Code
- Metallic industrial piping: DIN EN 13480
- Unfired pressure vessels: DIN EN 13445
- ASME B31.3 Process Piping Code
- Welder Performance Qualification Records per ASME BPVC Section IX
- Qualification test of welders: DIN EN 287

Testing

- ANSI and ASTM testing
- Non-destructive testing – Penetrant testing: DIN EN ISO 3452
- Hardness
- Hydrostatic pressure test: Pressure Equipment Directive 2014/68/EU, DIN EN 13480-5 and DIN EN 13445-5
- Spray and flow testing
- Phase Doppler Anemometry (PDA) measurement system
- Magnetic particle inspection : DIN EN ISO 17638
- Positive Material Identification



Talk to us

Your requirements are the first step towards a solution. We are more than happy to help you solve your individual tasks. Tell us your objectives and we will take care of the solution. If the solution is not yet available, we will tailor-make one for you. That is our promise.

FOR YOUR NOTES

FOR YOUR NOTES

**ENGINEERING
YOUR SPRAY SOLUTION**



LECHLER WORLD-WIDE

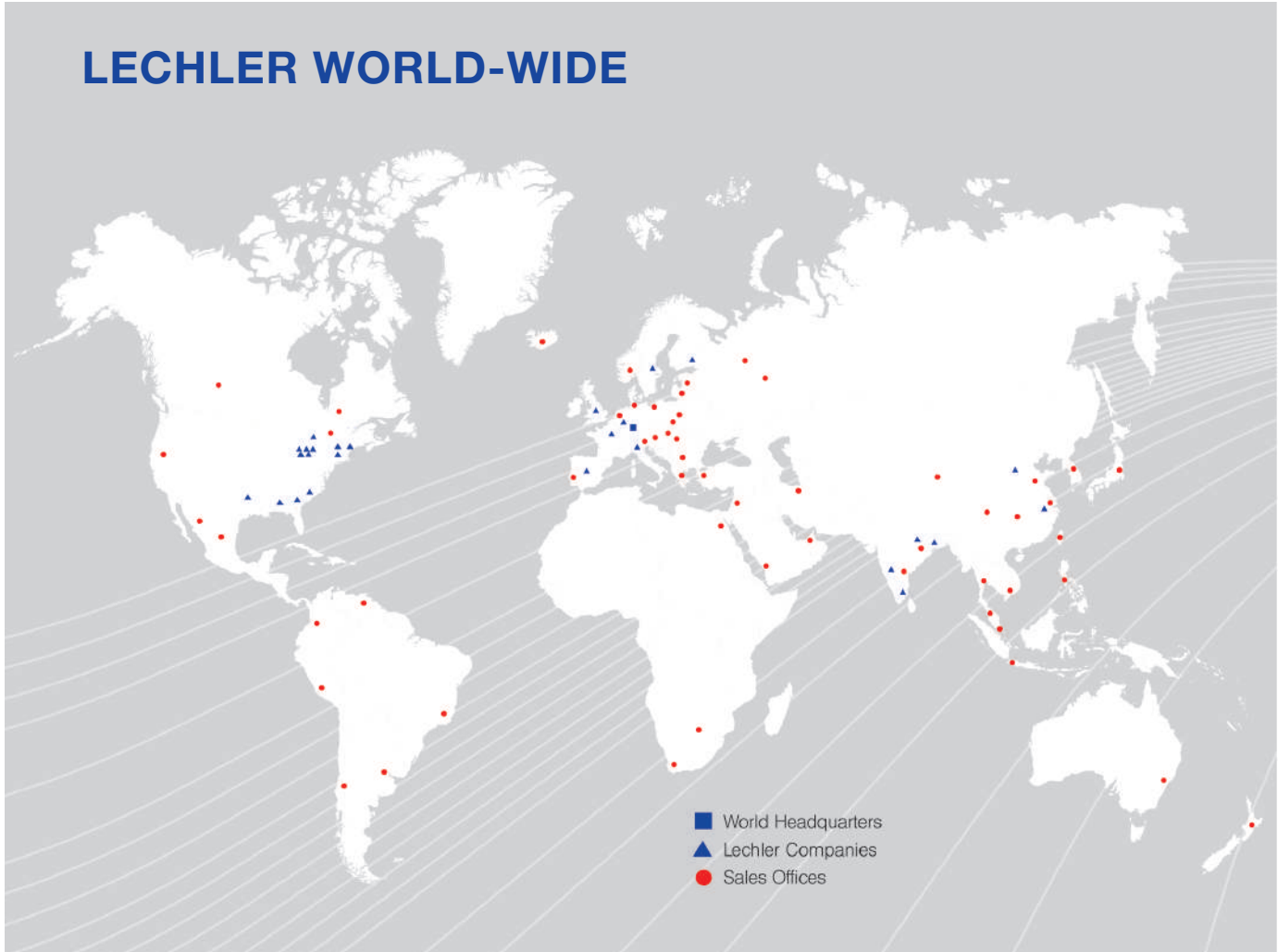

Edition 2/20 · Subject to technical modification.

Lechler, Inc · Precision Nozzles · Nozzle Systems

445 Kautz Road, St. Charles, IL 60174 · Phone (800) 777-2926 · Fax (630) 377-6657 · info@LechlerUSA.com · www.LechlerUSA.com

ASEAN: Lechler Spray Technology Sdn. Bhd. · No. 23, Jalan Teknologi 3/3A · Taman Sains Selangor 1 · Kota Damansara, PJU 5 · 47810 Petaling Jaya · Malaysia · info@lechler.com.my

Belgium: Lechler S.A./N.V. · Avenue Mercator, 6 · 1300 Wavre · Phone: +32 10 225022 · Fax: +32 10 243901 · info@lechler.be

China: Lechler Intl. Trad. Co. Ltd. · Beijing · Rm. 418 Landmark Tower · No. 8 Dong San Huan Bei Lu · Phone: +86 10 84537968, Fax: +86 10 84537458 · info@lechler.com.cn

Finland: Lechler Oy · Jäspilänkatu 18 · 04250 Kerava · Phone: +358 207 856880 · Fax: +358 207 856881 · info@lechler.fi

France: Lechler France, S.A. · Bât. CAP2 · 66-72, Rue Marceau · 93558 Montreuil · Phone: +33 1 49882600 · Fax: +33 1 49882609 · info@lechler.fr

Germany: Lechler GmbH · PO Box 13 23 · 72544 Metzingen · Phone: +49 7123 962-0 · Fax: (49) 7123 962-444 · info@lechler.de

Great Britain: Lechler Ltd. · 1 Fell Street, Newhall · Sheffield, S9 2TP · Phone: +44 114 2492020 · Fax: +44 114 2493600 · info@lechler.com

India: Lechler (India) Pvt. Ltd. · Plot B-2 · Main Road · Wagle Industrial Estate · Thane (W) · 400604 · Phone: +91 22 40634444 · Fax: +91 22 40634498 · lechler@lechlerindia.com

Italy: Lechler Spray Technology S.r.l. · Via Don Dossetti, 2 · 20080 Carpiano (MI) · Phone: +39 02 98859027 · Fax: +39 02 9815647 · info@lechleritalia.com

Spain: Lechler S.A. · Avda. Pirineos 7 · Oficina B7, Edificio Inbisa I · 28700 San Sebastián de los Reyes, Madrid · Phone: +34 91 6586346 · Fax: +34 91 6586347 · info@lechler.es

Sweden: Lechler AB · Kungsängsvägen 31 B · 753 23 Uppsala · Phone: +46 18 167030 · Fax: +46 18 167031 · info@lechler.se