

ENGINEERING  
YOUR SPRAY SOLUTION

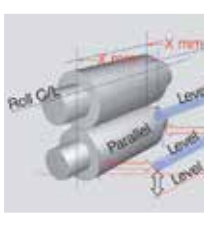

## Precision Nozzles and Systems for Roll Cooling Solutions in Rolling Mills

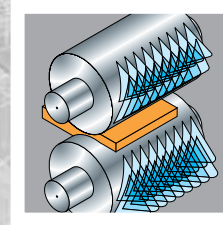
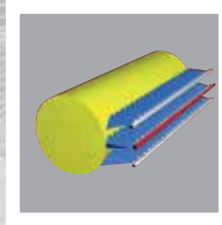
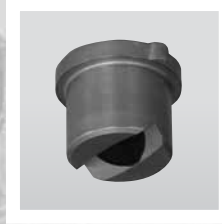
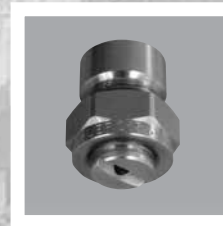
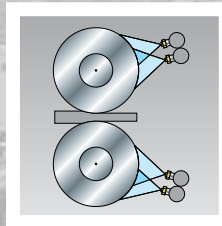

**Roll Cooling**

# LECHLER WORLDWIDE

## COMPETENCE IN THE METALLURGICAL INDUSTRY

Lechler nozzles have been setting standards in quality, performance and design for over 140 years.

A wide range of specially developed and proven nozzles of many different designs and in a range of materials is available for applications throughout the processes of metal smelting, refining, casting, rolling and processing. You can also select from over 20.000 other Lechler nozzles for a very wide range of other applications – with new ones being added to the range daily!



### A dynamic market with high expectations

Global steel production will increase dramatically in the years ahead. The globalization of the steel industry is not yet complete.

Every year, new steel-making companies are being newly formed, with production plants on every continent. The trend is similar in the case of the aluminium industry and the producers of non-ferrous metals.

### The metallurgical industry places stringent demands on its suppliers

Most metallurgical plant and machine builders are already organised and active globally. Process optimisations, along with new technologies, enable production capacities to be

permanently increased and the product quality of the metals produced to be further improved. Nozzles and nozzle systems play an important role here in all production stages.

The following basic requirements must be met for a successful partnership:

**Great innovative strength** in order to realize new technologies.

**High problem-solving competence** for ensuring plant availability.

**Global organization** as a guarantee of customer proximity and worldwide service.

Lechler meets these requirements in full.

### Wherever you are in the world, Lechler is close by and employs over 680 people

With production facilities in Germany, the USA, England, Hungary, India and China, sales offices in France, Spain, the BENELUX countries, Sweden and Finland, and representatives in over 25 countries, Lechler has a global network of service stations. This guarantees technical support for plant operators, a supply of spare parts and ongoing training of maintenance staff throughout the world.



# NOZZLE AND HEADER ARRANGEMENT FUNDAMENTALS IN ROLL COOLING

In the process of rolling the most significant aspect is the generation of heat through friction and deformation in the roll bite. The most important aspects are:

- Maintaining uniform, stable roll temperatures, circumferentially around the roll and transversely across the roll with
- Creating optimum thermal crowns and minimum differential in temperature in the upper and lower work rolls with optimum heat extraction

Because of the current demands on mills to process much lighter exit gages from increased incoming hot strip thickness, much larger reductions are necessary on individual mill stands, such high reductions at a nominal width

result in a larger area of contact with corresponding higher rolling force, friction and heat generation.

These high reduction schedules combined with the requirement to produce widening range of material cross-sections with a more diverse range of softer and harder materials also result in increasingly greater challenges in the control of roll temperature and the effective transfer / extraction of heat. Establishing a uniform homogenous cooling across the rolling width with a uniform and acceptable thermal distribution (no gradients) is the ultimate goal as regards cooling and assures that the universal problem of post cooled shape after recoil is minimized. A well designed, cooling system in good operating condition will achieve

several important objectives

- Maximum heat extraction at minimal coolant consumption
- Symmetrical thermal profiles on the work rolls (minimum gradient in temperature)
- Controlled thermal crowns
- “Normal” steady state roll temperatures
- No differentials in the thermal conditions between the top and bottom work roll
- Ensure that the roll bending system is kept within range by maintaining the appropriate thermal crown height and symmetry

CONTENTS	Page
<b>Fundamentals in roll cooling</b>	<b>3</b>
<b>Thermal roll cooling studies</b>	<b>4</b>
<b>Optimize your process</b>	<b>5</b>
<b>Products</b>	<b>6</b>
<b>Roll Cooling flat fan nozzle</b>	
Series 6E	6-7
Series 6F	8-9
<b>Flat fan dovetail nozzles</b>	
Series 660	10-11
Series 664/665	12-13
Series 669	14
Series 672/673	15
<b>Selectospray® roll cooling system for strip shape control</b>	<b>16-17</b>
<b>Accessories</b>	<b>18</b>

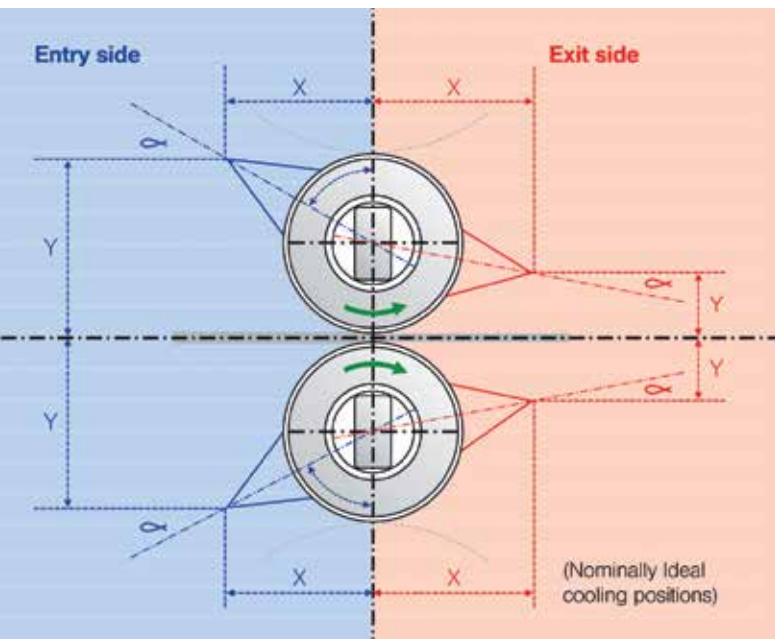

Symmetrical top and bottom roll cooling arrangements

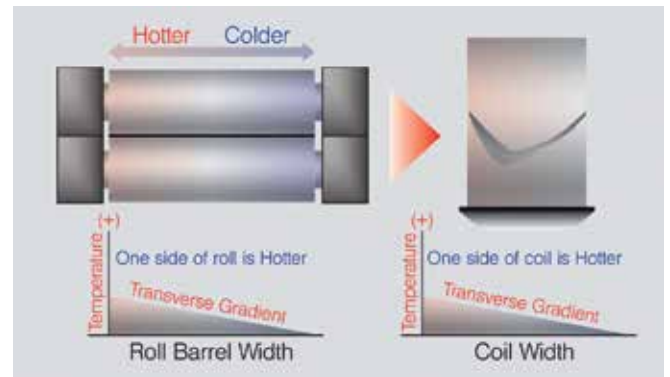

Roll and coil transverse temperature gradients

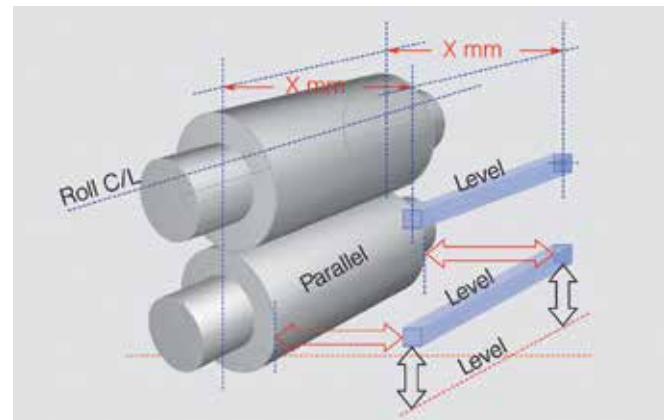

Top and bottom spray header in line (parallel) to center lines of work rolls



# FOR HIGHER PRODUCT QUALITY AND PRODUCTIVITY

## THERMAL ROLL COOLING STUDIES

Over the life span of a rolling mill the requirements in terms of product quality and the range of steel grades may change significantly. In particular the capability of the installed roll cooling systems needs to be investigated as one of the key technology area when it comes to process modifications aiming for higher productivity.

Lechler has the competence and experience to help you optimize your roll cooling system performance. We have engineered and installed over 350 selective roll cooling systems in steel, aluminum and nonferrous rolling mills. In addition to this, a large number of conventional roll cooling systems in hot and cold rolling mills have been revamped.

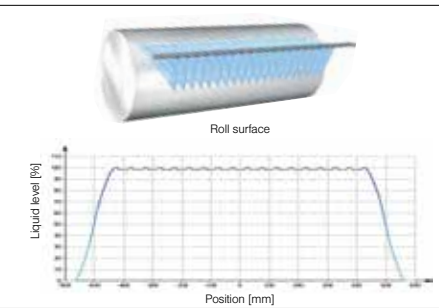

Optimum strip flatness thanks to simulation of the nozzle arrangement

Where the capability of Lechler was limited to the investigation of the coolant volume distribution characteristic Lechler can now also simulate the **thermal cooling effect** of the existing work roll sprays with a computer model.

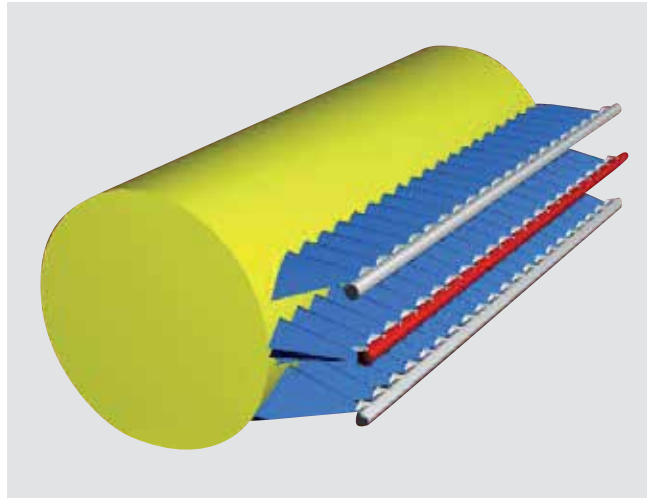

Roll cooling nozzle arrangement

### Thermal roll cooling studies help to:

- Improve product quality
- Increase mill speed and productivity
- Experience of 350 Roll cooling systems installed
- Optimized roll cooling headers and nozzles from one source

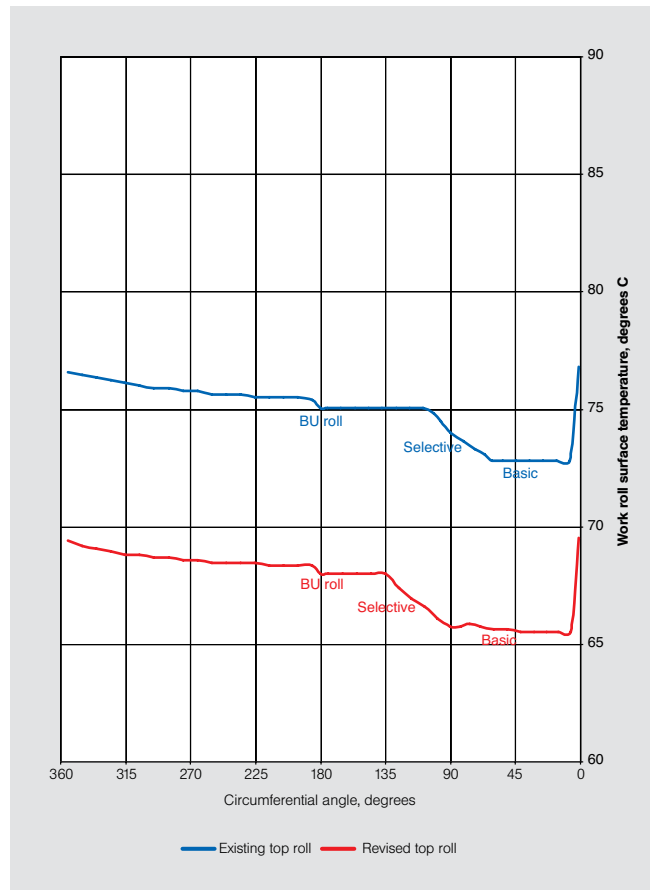

Circumferential work roll temperature profile before (blue) and after (red) optimization

# SAFE COSTS AND ENERGY OPTIMIZE YOUR PROCESS

A roll cooling study is a systematic and structured approach and delivers a wide range of benefits by determining the improvements that can be obtained by an upgraded cooling system with improved operation and maintenance practices. The thoroughly documented final report, containing collected and analysed data and a proposal for future improvements through a system upgrade, forms a comprehensive and indispensable tool for decision making.

A study also identifies problems and causes which were previously not recognized. The time, efforts and cost of such work is insignificant in comparison with the potential benefits of a properly executed study which results in an optimized roll cooling system and the subsequent improvements in product quality, productivity and reduced operation costs.

## Roll Cooling Study Phase 1

A typical roll cooling study would be carried out in two phases:

In Phase 1, a site visit is the start during which mill data would be collected.

### Benchmarking

Also included in Phase 1 would be the benchmarking of the cooling effect of the existing header and nozzle arrangement. Based on the cooling effect and the heat input data the top and bottom work roll temperature can be calculated. Spray cooling asymmetries and any other problematic areas would be highlighted in the final report for phase 1. Speed and work roll diameter differences are considered.

## Roll Cooling Study Phase 2

There can be a number of reasons for conducting a study. The most common are:

- Identify strip shape defects and to eliminate them
- Extend work roll life time
- Increase rolling speed and productivity
- Improve maintenance friendliness and reduce costs
- Optimize coolant flow and hence save energy and coolant treatment costs
- Change of product formats and steel grades (product mix)

## Objectives

In most cases it is a combination of all six reasons that determines the objectives for a revamp of the roll cooling system. It is important that these objectives are clearly defined so as to provide the study with a clear focus when preparing the final study report.

Based on the result of the benchmarking and the objectives, the required cooling effect and the new heat input into the work rolls would be calculated. With these as an input, a recommendation for an optimized nozzle and header arrangement would be worked out for every stand.

## Mill Types

Roll cooling studies can be performed for the following flat rolling mills:

- Steel hot strip mills
- Tandem steel cold rolling mills
- Reversing steel cold rolling mills
- Steel plate rolling mills
- Every type of aluminum hot, cold and foil rolling mill
- Every type of NF-rolling mill (copper, brass etc.)

## Lechler scope of supply

### Phase 1 - Existing

- Performance of the entire site survey including the roll temperature measurements
- Presentation of the final report of Phase 1 (benchmarking)

### Phase 2 - Optimization

- Calculation of the newly set cooling parameters which includes total coolant flow rates and pressures
- Complete basic and detailed engineering for new nozzle and header arrangement
- Manufacturing and supply of the new set of nozzles and accessories
- Fabrication and supply of the new set of roll cooling headers



Optimized spray header designed and fabricated by Lechler

**Please contact Lechler for a first discussion regarding the optimization of your roll cooling system.**



# Roll cooling flat fan nozzle

## Series 6E

**Patented**

The correct alignment of the roll cooling nozzles on the spray header is essential for optimal roll cooling. Flat jets are the preferred spray pattern for roll cooling, therefore only a self aligning nozzle design provides the operation safety required in a modern rolling mill.

All flat jet nozzles of the Lechler series 6E4 and 6E5 come with an automatic self aligning feature which ensures that

every nozzle will always be installed under the correct spray offset angle towards the roll center line.

No welding nipple is required for the 6E nozzle series because the tip geometry can be machined directly into a front plate of a box type spray header. A hollow nozzle nut holds the nozzle tip in place. This simple but innovative design does make all the

welding nipples and the intermediate nozzle plate obsolete resulting in significant cost savings. Another positive aspect is the reduction of the overall weight and outer dimensions of box type headers.

The correct offset angle is machined directly into the header front plate and does not depend on the nozzle tip. The two keys on the nozzle tip are

always in line with the flat jet spray axis.

This prevents wrong fabrication caused by design mistakes.

The nozzle tip seals metalically against the bottom of the header plate machined surface.

The Spray has a parabolic liquid distribution which is ideal for a multi nozzle header arrangement.

- Parabolic liquid distribution
- Automatic nozzle alignment
- High operation safety
- No welding nipples required
- Simplifies the design of boxtype headers because:
  - No welding nipples required
  - Reduces header weight
  - Reduces outer header dimension
  - Reduces header costs significantly

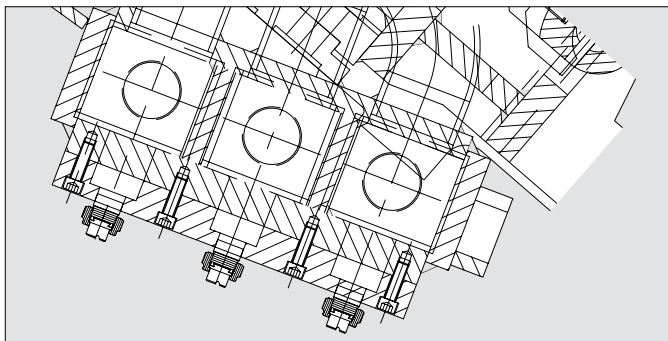

Example of conventional box type header

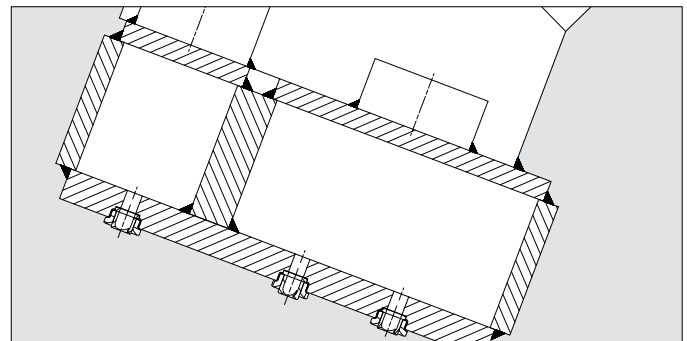

Example of new box type header with 6E series nozzle

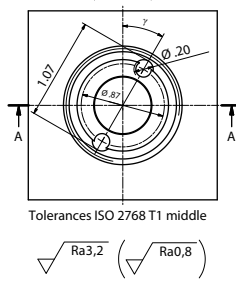
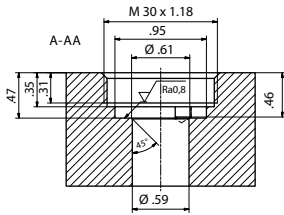

Spray width [B] at p=45 psi

	H 10 in	H 20 in
6E4.721 - 6E4.921	3.94	7.87
6E4.941 - 6E5.201	4.53	8.27
6E4.722 - 6E4.962	5.91	11.81
6E4.982 - 6E5.202	6.3	11.81
6E4.723 - 6E4.963	8.66	17.32
6E4.983 - 6E5.203	9.84	19.29
6E4.724 - 6E4.964	12.99	24.8
6E5.984 - 6E5.204	13.39	25.2

### Accessories

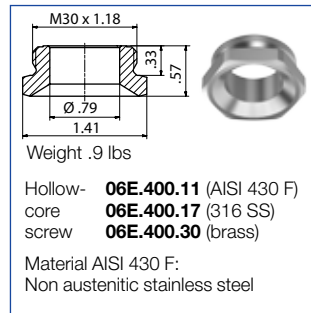
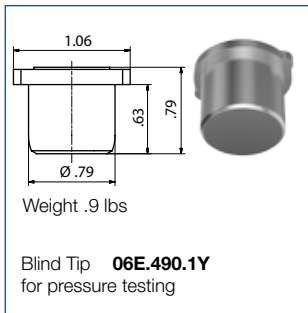

Ordering no.				Mat. no.	Equivalent Orifice diam. (in.)	Flow Rate (Gallons Per Minute)													
Type						316 SS 17	Brass 30	10 psi		20 psi		40 psi		60 psi		80 psi		100 psi	
Spray Angle								10	20	40	60	80	100	10	20	40	60	80	100
20°	30°	45°	60°			psi	psi	psi	psi	psi	psi	psi	psi	psi	psi	psi	psi		
6E4. 721	6E4. 722	6E4. 723	6E4. 724	○	○	.08-.10	0.98	1.38	6,30	1.95	2.39	2.76	3.09						
6E4. 761	6E4. 762	6E4. 763	6E4. 764	○	○	.09-.11	1.24	1.76	8,00	2.48	3.04	3.51	3.92						
6E4. 801	6E4. 802	6E4. 803	6E4. 804	○	○	.10-.13	1.55	2.19	10,00	3.10	3.80	4.39	4.91						
6E4. 841	6E4. 842	6E4. 843	6E4. 844	○	○	.12-.14	1.94	2.74	12,50	3.88	4.75	5.49	6.13						
6E4. 881	6E4. 882	6E4. 883	6E4. 884	○	○	.13-.16	2.48	3.51	16,00	4.96	6.08	7.02	7.85						
6E4. 921	6E4. 922	6E4. 923	6E4. 924	○	○	.16-.17	3.10	4.39	20,00	6.21	7.60	8.78	9.81						
6E4. 941	6E4. 942	6E4. 943	6E4. 944	○	○	.18-.20	3.48	4.91	22,40	6.95	8.51	9.83	10.99						
6E4. 961	6E4. 962	6E4. 963	6E4. 964	○	○	.17-.21	3.88	5.49	25,00	7.76	9.50	10.97	12.27						
6E4. 981	6E4. 982	6E4. 983	6E4. 984	○	○	.17-.20	4.34	6.14	28,00	8.69	10.64	12.29	13.74						
6E5. 001	6E5. 002	6E5. 003	6E5. 004	○	○	.19-.23	4.89	6.91	31,50	9.77	11.97	13.82	15.45						
6E5. 011	6E5. 012	6E5. 013	6E5. 014	○	○	.19-.23	5.20	7.35	33,50	10.39	12.73	14.70	16.44						
6E5. 041	6E5. 042	6E5. 043	6E5. 044	○	○	.22-.26	6.21	8.78	40,00	12.41	15.20	17.55	19.62						
6E5. 061	6E5. 062	6E5. 063	6E5. 064	○	○	.23-.26	6.98	9.87	45,00	13.96	17.10	19.75	22.08						
6E5. 081	6E5. 082	6E5. 083	6E5. 084	○	○	.26-.29	7.76	10.97	50,00	15.51	19.00	21.94	24.53						
6E5. 121	6E5. 122	6E5. 123	6E5. 124	○	○	.29-.33	9.77	13.82	63,00	19.55	23.94	27.65	30.91						
6E5. 161	6E5. 162	6E5. 163	6E5. 164	○	○	.33	12.41	17.55	80,00	24.82	30.40	35.11	39.25						
6E5. 181	6E5. 182	6E5. 183	6E5. 184	○	○	.35-.41	13.96	19.75	90,00	27.93	34.20	39.49	44.15						
6E5. 201	6E5. 202	6E5. 203	6E5. 204	○	○	.38-.41	15.51	21.94	100,00	31.03	38.00	43.88	49.06						

Example Type + Material no. = Ordering no.  
for ordering: 6E4. 721 + 17 = 6E4. 721. 17

Subject to technical modifications

Conversion formula for the above series:  $V_2 = V_1 \sqrt{\frac{P_2}{P_1}}$

# 6F SERIES

## ROLL COOLING FLAT JET NOZZLE

**Patented**

The correct alignment of the roll cooling nozzles on the spray header is essential for optimal roll cooling. Flat jets are the preferred spray pattern for roll cooling, therefore only a self-aligning nozzle design provides the operation safety required in a modern rolling mill.

All flat jet nozzles of the Lechler series 6F4 and 6F5 come with an automatic self-aligning feature which ensures that every nozzle will always be

installed under the correct spray offset angle towards the roll center line. The nozzle tip has two locating lugs for self-alignment and seals metalically with a circular surface against the welding nipple when the nut is tightened. No torque is applied on the lugs themselves preventing mechanical damage due to over tightening of the nut.

The 6F nozzle series are ideal for mounting when space

is limited. Unlike the dove tail assemblies the tip is put in in axial direction of the welding nipple. Safe and one-handed nozzle tip mounting is guaranteed because thread engagement does not take place before the two location lugs have been correctly positioned on the opposite nipple side.

The 6F nozzle series is available with a wide variety of standard offset angles

which simplifies spray header fabrication significantly. It also helps to prevent wrong fabrication of headers.

The spray has a parabolic liquid distribution which is ideal for a multi nozzle header arrangement

- Parabolic liquid distribution
- Automatic nozzle alignment
- High operation safety
- Secure one-handed axial mounting
- Mechanical damage prevented
- Variety of standard offset angles
- Design and fabrication errors prevented

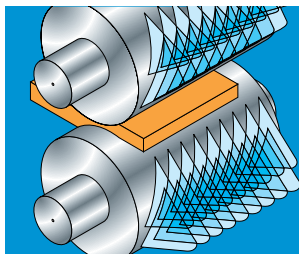
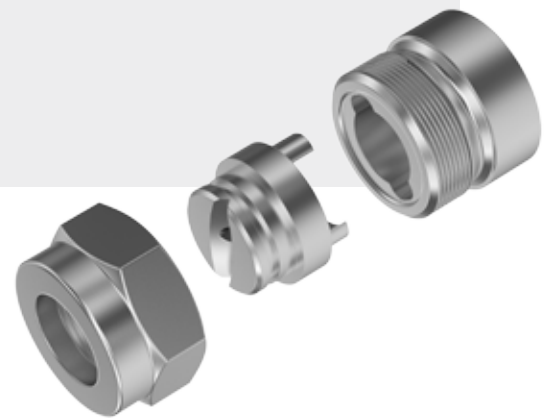
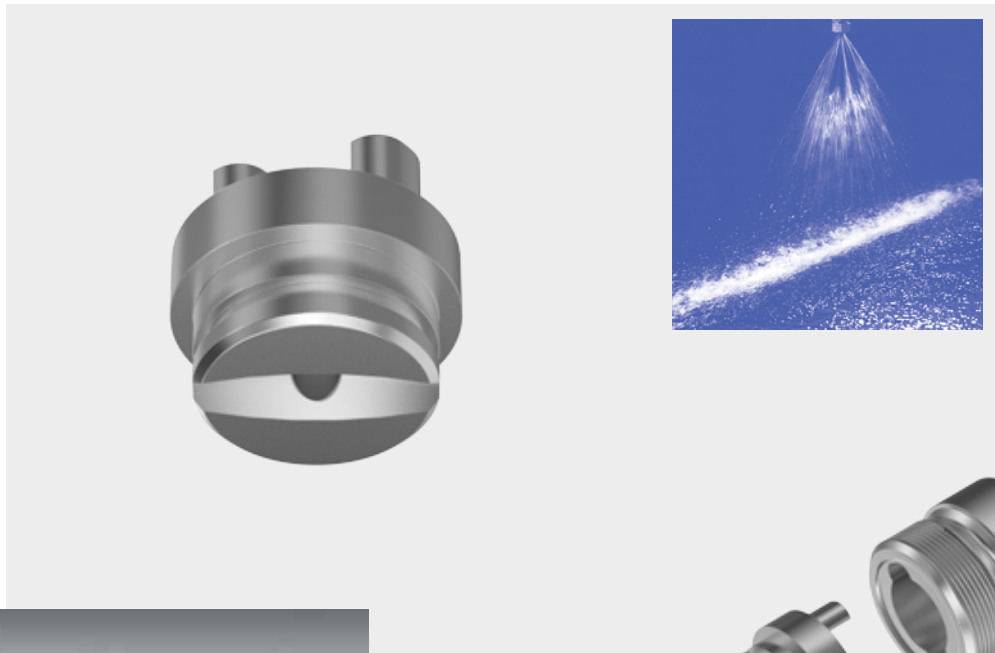



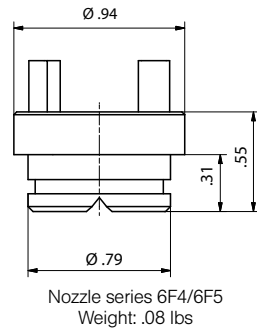

Spray width [B] at p=40 psi

	H 10 in	H 20 in
6F4.721 - 6F4.921	3.94	7.87
6F4.941 - 6F5.201	4.53	8.27
6F4.722 - 6F4.962	5.91	11.81
6F4.982 - 6F5.202	6.3	12.20
6F4.723 - 6F4.963	8.66	17.32
6F4.983 - 6F5.203	9.84	19.29
6F4.724 - 6F4.964	12.99	24.8
6F5.984 - 6F5.204	13.39	25.2

Ordering code for offset angle	
Offset angle $\gamma$	Ordering code
15°	15
20°	20
25°	25
30°	30
35°	35
40°	40
45°	45
50°	50
60°	60
70°	70

## Accessories

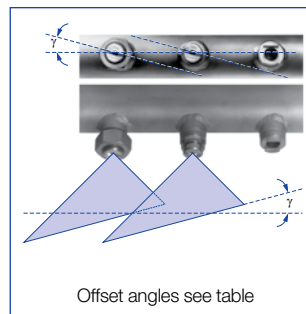
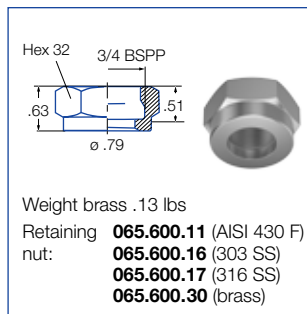
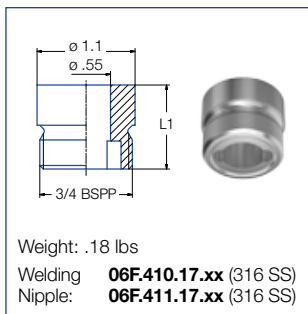

Technical data and ordering data for accessories see page 18.

Ordering no.				Mat. no. 303 SS 16	316 SS 17	Offset angle	Equivalent Orifice diam. (in.)	Flow Rate (Gallons Per Minute)							
Type								liters per minute 2 bar							
Spray Angle								10 psi	20 psi	40 psi	60 psi	80 psi	100 psi		
20°	30°	45°	60°												
6F4. 721	6F4. 722	6F4. 723	6F4. 724	○	○	Code for offset angle – see separate table below	.08-.10	0.98	1.38	6.30	1.95	2.39	2.76	3.09	
6F4. 761	6F4. 762	6F4. 763	6F4. 764	○	○		.09-.11	1.24	1.76	8.00	2.48	3.04	3.51	3.92	
6F4. 801	6F4. 802	6F4. 803	6F4. 804	○	○		.10-.13	1.55	2.19	10.00	3.10	3.80	4.39	4.91	
6F4. 841	6F4. 842	6F4. 843	6F4. 844	○	○		.12-.14	1.94	2.74	12.50	3.88	4.75	5.49	6.13	
6F4. 881	6F4. 882	6F4. 883	6F4. 884	○	○		.13-.16	2.48	3.51	16.00	4.96	6.08	7.02	7.85	
6F4. 921	6F4. 922	6F4. 923	6F4. 924	○	○		.16-.17	3.10	4.39	20.00	6.21	7.60	8.78	9.81	
6F4. 941	6F4. 942	6F4. 943	6F4. 944	○	○		.18-.20	3.48	4.91	22.40	6.95	8.51	9.83	10.99	
6F4. 961	6F4. 962	6F4. 963	6F4. 964	○	○		.17-.21	3.88	5.49	25.00	7.76	9.50	10.97	12.27	
6F4. 981	6F4. 982	6F4. 983	6F4. 984	○	○		.17-.20	4.34	6.14	28.00	8.69	10.64	12.29	13.74	
6F5. 001	6F5. 002	6F5. 003	6F5. 004	○	○		.19-.22	4.89	6.91	31.50	9.77	11.97	13.82	15.45	
6F5. 011	6F5. 012	6F5. 013	6F5. 014	○	○		.19-.23	5.20	7.35	33.50	10.39	12.73	14.70	16.44	
6F5. 041	6F5. 042	6F5. 043	6F5. 044	○	○		.22-.26	6.21	8.78	40.00	12.41	15.20	17.55	19.62	
6F5. 061	6F5. 062	6F5. 063	6F5. 064	○	○		.23-.26	6.98	9.87	45.00	13.96	17.10	19.75	22.08	
6F5. 081	6F5. 082	6F5. 083	6F5. 084	○	○		.26-.29	7.76	10.97	50.00	15.51	19.00	21.94	24.53	
6F5. 121	6F5. 122	6F5. 123	6F5. 124	○	○		.29-.33	9.77	13.82	63.00	19.55	23.94	27.65	30.91	
6F5. 161	6F5. 162	6F5. 163	6F5. 164	○	○		.33	12.41	17.55	80.00	24.82	30.40	35.11	39.25	
6F5. 181	6F5. 182	6F5. 183	6F5. 184	○	○		.35-.41	13.96	19.75	90.00	27.93	34.20	39.49	44.15	
6F5. 201	6F5. 202	6F5. 203	6F5. 204	○	○		.38-.41	15.51	21.94	100.00	31.03	38.00	43.88	49.06	

Example Type + Material no. + Offset angle = Ordering no.  
for ordering: 6F4. 721 + 17 = 6F4. 721. 17. 15

Subject to technical modifications

Conversion formula for the above series:  $V_2 = V_1 \sqrt{\frac{P_2}{P_1}}$

# Flat fan dovetail nozzles

## Series 660

The 660 series nozzles come with the conventional, automatic self aligning dovetail connection which ensures that every nozzle will always be installed under the correct spray offset angle towards the roll center line.

The small tip dimensions make this nozzle series ideal for roll cooling and strip cooling headers when space is limited especially in small rolling mills for non ferrous metals.

All tips have an automatically built in 5° offset angle if the welding nipple is welded in line with the centre line of the spray header. Any other offset angle has to be compensated for by welding the nipple under a different angle (minus the 5° inbuilt offset angle).

The spray has a parabolic liquid distribution which is ideal for a multi nozzle header arrangement.

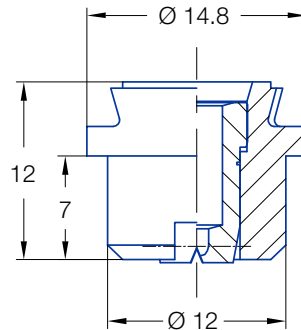
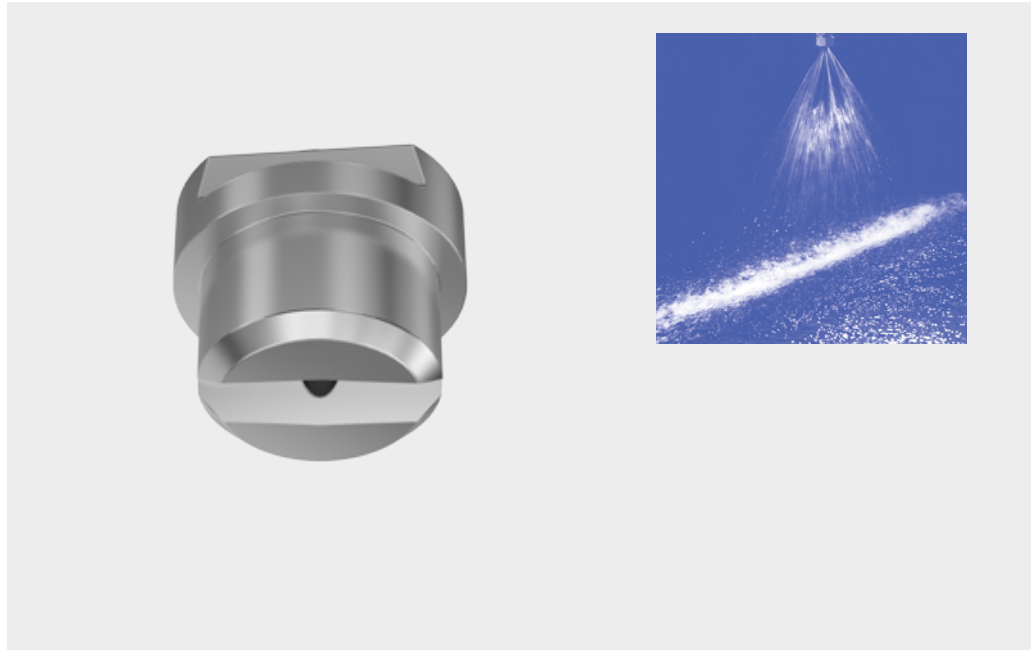

Weight brass: .05 lbs

### Accessories

Weight: .14 lbs  
 Welding **066.011.17** (316 SS)  
 Nipple:

Weight brass .13 lbs  
 Retaining nut: **065.200.16** (303 SS)  
**065.200.17** (316 SS)  
**065.200.30** (brass)

Other offset angles are available on request

Technical data and ordering data for accessories see page 18.



# Flat fan dovetail nozzles

## Series 664/665

The 664 and 665 series nozzles come with the conventional, automatic self aligning dovetail connection which ensures that every nozzle will always be installed under the correct spray offset angle towards the roll center line.

This nozzle family has become an industrial standard solution for roll cooling applications.

All tips have an automatically built in 15° offset angle if the welding nipple is welded in line with the centre line of the spray header. Any other offset angle has to be compensated for by welding the nipple under a different angle (minus the 15° inbuilt offset angle).

The spray has a parabolic liquid distribution which is ideal for a multi nozzle header arrangement.

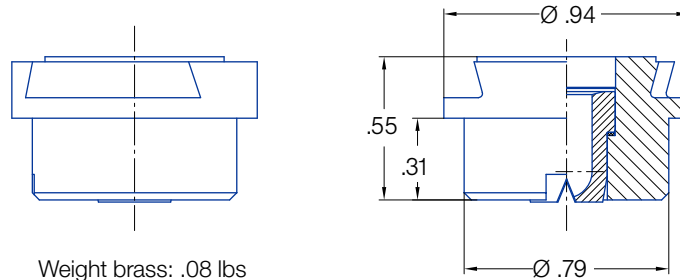
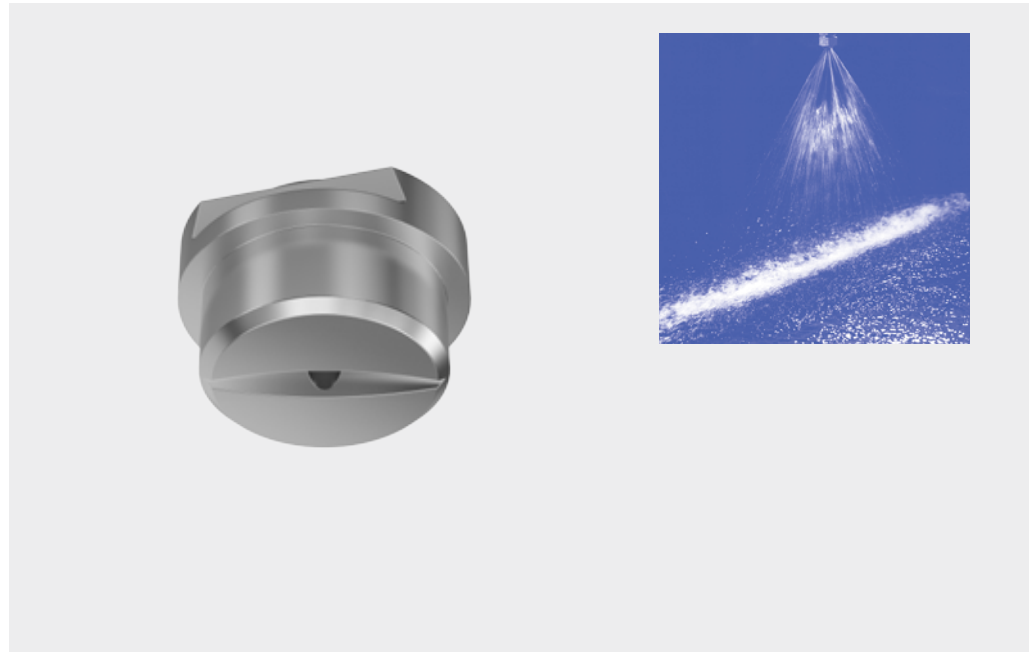

### Accessories

Weight: .14 lbs  
 Welding: **066.410.17** (316 SS)  
 Nipple: **066.410.03** (1.0570)

Weight brass .13 lbs  
 Retaining nut: **065.600.11** (AISI 430 F)  
**065.600.16** (303 SS)  
**065.600.17** (316 SS)  
**065.600.30** (brass)

Other offset angles are available on request

Technical data and ordering data for accessories see page 18.



Ordering no.				Material no.			Equivalent Orifice diam. (in.)	Flow Rate (Gallons Per Minute)						
Type				303 SS 16	316 SS 17	Brass 30		10 psi	20 psi	liters per minute 2 bar	40 psi	60 psi	80 psi	100 psi
Spray Angle														
20°	30°	45°	60°											
664.721	664.722	664.723	664.724	○	○	○	.08-.10	0.98	1.38	6.3	1.95	2.39	2.76	3.09
664.761	664.762	664.763	664.764	○	○	○	.09-.11	1.24	1.76	8.0	2.48	3.04	3.51	3.92
664.801	664.802	664.803	664.804	○	○	○	.10-.13	1.55	2.19	10.0	3.10	3.80	4.39	4.91
664.841	664.842	664.843	664.844	○	○	○	.12-.14	1.94	2.74	12.5	3.88	4.75	5.49	6.13
664.881	664.882	664.883	664.884	○	○	○	.13-.16	2.48	3.51	16.0	4.96	6.08	7.02	7.85
664.921	664.922	664.923	664.924	○	○	○	.16-.17	3.10	4.39	20.0	6.21	7.60	8.78	9.81
664.941	664.942	664.943	664.944	○	○	○	.18-.20	3.48	4.91	22.4	6.95	8.51	9.83	10.99
664.961	664.962	664.963	664.964	○	○	○	.17-.21	3.88	5.49	25.0	7.76	9.50	10.97	12.27
664.981	664.982	664.983	664.984	○	○	○	.17-.20	4.34	6.14	28.0	8.69	10.64	12.29	13.74
665.001	665.002	665.003	665.004	○	○	○	.19-.22	4.89	6.91	31.5	9.77	11.97	13.82	15.45
665.011	665.012	665.013	665.014	○	○	○	.19-.23	5.20	7.35	33.5	10.39	12.73	14.70	16.44
665.041	665.042	665.043	665.044	○	○	○	.22-.26	6.21	8.78	40.0	12.41	15.20	17.55	19.62
665.061	665.062	665.063	665.064	○	○	○	.23-.26	6.98	9.87	45.0	13.96	17.10	19.75	22.08
665.081	665.082	665.083	665.084	○	○	○	.26-.29	7.76	10.97	50.0	15.51	19.00	21.94	24.53
665.121	665.122	665.123	665.124	○	○	○	.29-.33	9.77	13.82	63.0	19.55	23.94	27.65	30.91
665.161	665.162	665.163	665.164	○	○	○	.33	12.41	17.55	80.0	24.82	30.40	35.11	39.25
665.181	665.182	665.183	665.184	○	○	○	.35-.41	13.96	19.75	90.0	27.93	34.20	39.49	44.15
665.201	665.202	665.203	665.204	○	○	○	.38-.41	15.51	21.94	100.0	31.03	38.00	43.88	49.06

**Example**    Type    +    Material no.    =    Ordering no.  
for ordering: 664.721    +    17                    =    664.721.17

Subject to technical modifications

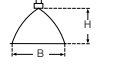
Spray width [B] at p=45 psi		
	H	H
	10 in	20 in
664.721 - 664.921	3.94	7.87
664.941 - 665.201	4.53	8.27
664.722 - 664.962	5.91	11.81
664.982 - 665.202	6.3	12.20
664.723 - 664.963	8.66	17.32
664.983 - 665.203	9.84	19.29
664.724 - 664.964	12.99	24.8
665.984 - 665.204	13.39	25.2

Conversion formula for the above series:  $V_2 = V_1 \sqrt{\frac{P_2}{P_1}}$

# Flat fan dovetail nozzles

## Series 669

The 669 series nozzles come with the conventional, automatic self aligning dovetail connection which ensures that every nozzle will always be installed under the correct spray offset angle towards the roll center line.

This nozzle family allow very large flow rates for roughing mill, plate mill and strip coling applications.

All tips have an automatically built in 15° offset angle if the welding nipple is welded in line with the center line of the spray header. Any other offset angle has to be compensated for by welding the nipple under a different angle (minus the 15° inbuilt offset angle).

The spray has a parabolic liquid distribution which is ideal for a multi nozzle header arrangement.

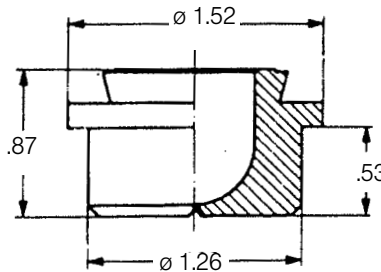
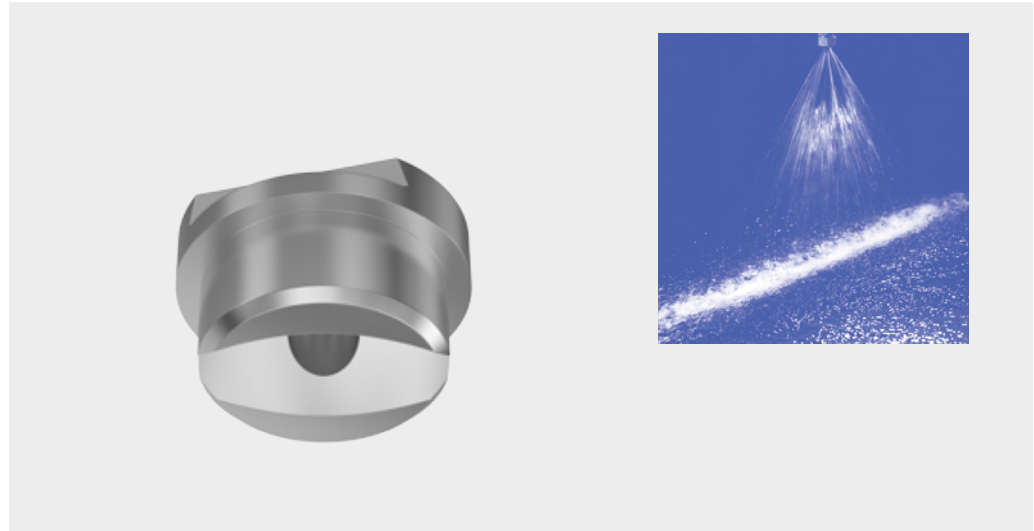

Weight brass: .30 lbs

### Accessories

Weight: .14 lbs  
 Welding **066.910.17** (316 SS)  
 Nipple: **066.910.02** (1.0159)

Weight brass .13 lbs  
 Retaining nut: **066.900.16** (303 SS)  
**066.900.17** (316 SS)  
**066.900.30** (brass)

Ordering no.				Material no.		Equivalent Orifice diam. (in.)	Flow Rate (Gallons Per Minute)						
Type				16	30		Spray Angle						
20°	30°	45°	60°				10 psi	20 psi	liters per minute 2 bar	40 psi	60 psi	80 psi	100 psi
<b>669.041</b>	<b>669.042</b>	<b>669.043</b>	<b>669.044</b>	○	○	.22-.26	6.21	8.78	40	12.41	15.20	17.55	19.62
<b>669.121</b>	<b>669.122</b>	<b>669.123</b>	<b>669.124</b>	○	○	.29-.33	9.77	13.82	63	19.55	23.94	27.65	30.91
<b>669.201</b>	<b>669.202</b>	<b>669.203</b>	<b>669.204</b>	○	○	.37-.42	15.51	21.94	100	31.03	38.00	43.88	49.06
<b>669.281</b>	<b>669.282</b>	<b>669.683</b>	<b>669.284</b>	○	○	.37-.51	24.82	35.11	160	49.65	60.80	70.21	78.50

Subject to technical modifications

**Example** Type + Material no. = Ordering no.  
 for ordering: 669.041 + 16 = 669.041.16

Technical data and ordering data for accessories see page 18.

Spray width [B] at p=40 psi	H	
	10 in	20 in
669.041 - 664.281	5	8
669.042 - 669.282	6	12
669.043 - 669.283	10	19
665.042 - 665.202	13	25

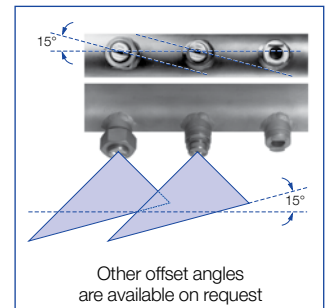

# Series 672/673

## Flat Fan Nozzle Tips

The 672/673 series nozzle tips with socket alignment flats offer the positive spray orientation of dovetail designs with key improvements.

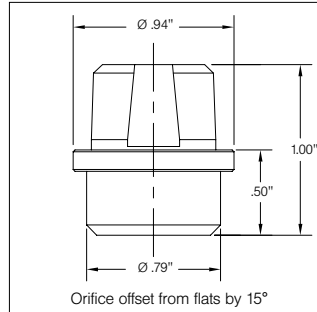

Theoretical Spray Width		Actual width may vary.	
Nozzle Angle		Width—in. (B)	
		10"	20"
20°	672.561-672.921	3	7
	672.961-673.121	4	8
30°	672.562-672.962	5	11
	673.012-673.122	6	12
45°	672.563-672.963	8	17
	672.013-673.123	9	19
60°	672.564-673.124	13	25
90°	672.566-672.766	18	34
	672.806-672.886	19	36
	672.926-672.966	21	40
	673.016		
120°	672.567-672.677	27	51
	672.727	29	54
	672.767	30	55
	672.807-672.927	31	57
	673.047-673.127	49	85

Ordering no.						Material no.			Equivalent Orifice diam. (in.)	Flow Rate (Gallons Per Minute)						
Type						303 SS 16	316 SS 17	Brass 30		10 psi	20 psi	liters per minute 2 bar	40 psi	60 psi	80 psi	100 psi
Spray Angle																
20°	30°	45°	60°	90°	120°											
672.561	672.562	672.563	672.564	672.566	672.567	-	○	○	.079	.39	.55	2.5	.78	.95	1.1	1.2
672.601	672.602	672.603	672.604	672.606	672.607	-	○	○	.087	.49	.69	3.2	.98	1.2	1.4	1.5
672.641	672.642	672.643	672.644	672.646	672.647	-	○	○	.099	.62	.88	4.00	1.24	1.52	1.75	1.96
672.671	672.672	672.673	672.674	672.676	672.677	-	○	○	.106	.74	1.04	4.75	1.47	1.80	2.08	2.33
672.721	672.722	672.723	672.724	672.726	672.727	-	○	○	.118	.98	1.38	6.30	1.95	2.39	2.76	3.09
672.761	672.762	672.763	672.764	672.766	672.767	-	○	○	.137	1.24	1.75	8.00	2.48	3.04	3.51	3.92
672.801	672.802	672.803	672.804	672.806	672.807	-	○	○	.157	1.55	2.19	10.0	3.10	3.80	4.39	4.90
672.841	672.842	672.843	672.844	672.846	672.847	-	○	○	.177	1.94	2.74	12.5	3.88	4.75	5.48	6.13
672.881	672.882	672.883	672.884	672.886	672.887	-	○	○	.197	2.48	3.51	16.0	4.96	6.08	7.02	7.85
672.921	672.922	672.923	672.924	672.926	672.927	-	○	○	.220	3.10	4.39	20.0	6.20	7.60	8.77	9.81
672.961	672.962	672.963	672.964	673.016		-	○	○	.236	3.88	5.48	25.0	7.75	9.50	10.9	12.2
673.041	673.042	673.043	673.044	673.046	673.047	○	-	○	.315	6.20	8.77	40.0	12.4	15.2	17.5	19.6
673.081	673.082	673.083	673.084	673.086		○	-	○	.354	7.75	10.9	50.0	15.5	18.9	21.9	24.5
673.121	673.122	673.123	673.124	673.126	673.127	○	-	○	.394	9.77	13.8	63.0	19.5	23.9	27.6	30.9

**Example** Type + Material no. = Ordering no.  
for ordering: 672.721 + 17 = 672.721.17

### Series 672/673 bases, caps and accessories

Ordering no. Type	Description	Material no.		
		303 SS 16	316 SS 17	Brass 30
<b>Bases</b>				
067.210.xx.01	Weld Base, 1.06" long		○	
067.210.xx.02	Weld Base, 1.37" long		○	
067.210.xx.03	Weld Base, 1.67" long		○	
067.211.xx.04	Weld Base, 2.37" long		○	
067.211.xx.06	Weld Base, 4.92" long		○	
067.211.xx.11	Weld Base, 7.08" long		○	
067.211.xx.13	Weld Base, 3.94" long		○	
067.216.xx.BK	Threaded, 3/4" NPT Male, 1.75" long		○	
<b>Caps</b>				
065.600.xx.00	Nozzle Tip Retainer Cap	○	○	○
<b>Accessories</b>				
006.721.xx.00	Alignment Tip — Right Hand			○
006.722.xx.00	Alignment Tip — Left Hand			○
006.723.xx.00	Alignment Tip — Center			○

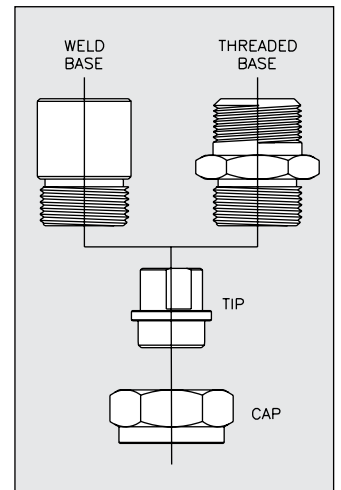

**Example** Type + Material no. (xx) = Ordering no.  
for ordering: 067.210.xx.01 + 17 = 067.210.17.01

Other base options are available.  
Please contact Lechler for more information.

# COLD ROLLING OF STEEL, HOT AND COLD ROLLING OF ALUMINIUM AND SELECTOSPRAY® ROLL COOLING SYSTEM FOR STRIP SHAPE CONTROL



**SELECTOSPRAY® – an indispensable actuator for shape control. It corrects reliably asymmetrical strip shape defects and supports work roll bending**

To date, more than 300 Lechler SELECTOSPRAY® roll cooling systems have been installed globally in cold rolling mills for steel, aluminium and non-ferrous metals, as well as in aluminium hot rolling mills and foil mills. Profit from our comprehensive know-how in this specialist area.

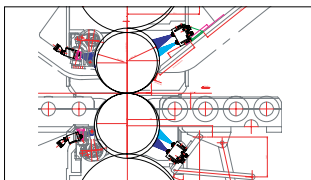

Selective roll cooling system, individually designed

## The principle

To achieve precise cooling control, the roll barrel is 'divided' into zones, each of which has coolant precisely applied to it by MODULAX valve controlled spray nozzles. Each of the zonal sprays can be operated independently of the others either manually, by push button control, semi automatically by a PLC, or automatically in connection with a shape control system.

The SELECTOSPRAY® system can be used in conjunction with any of the shape control systems currently available, the roll zoning being dimensioned to exactly match that of the shape metering roll involved. Zone widths for both automated and manually controlled systems are available, widths in general use being between 25 mm and 100 mm.

The SELECTOSPRAY® system includes complete headers, air hoses and control cabinet.

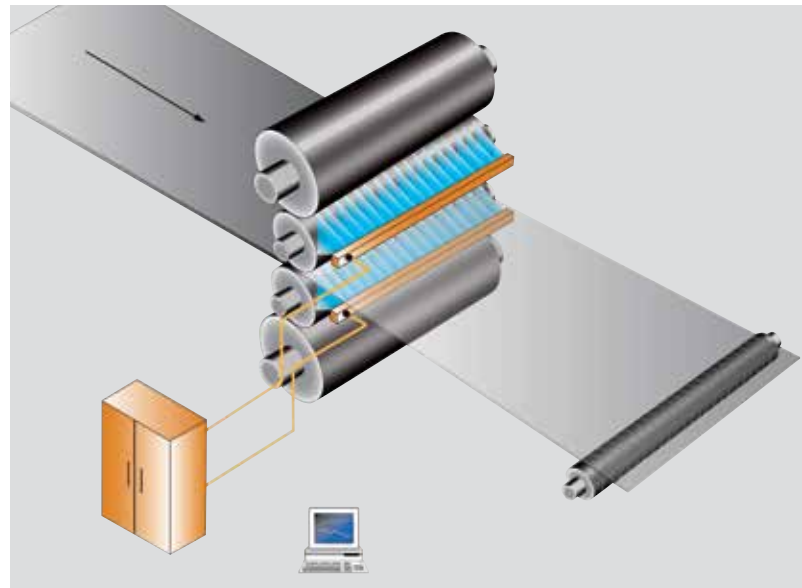

Electrically controlled SELECTOSPRAY® system with EVA valve technology (25 mm/1", 50 mm/2")



Control cabinet



Air and cable hoses

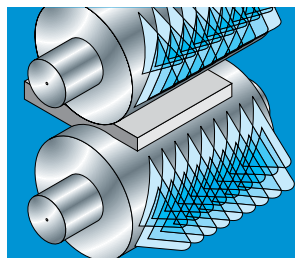



# AND NON-FERROUS METALS CONTROL

## Lechler competence and expertise

Of paramount importance for any roll cooling application is how the sprays impinge on the roll surface. An effective and precise footprint geometry is the fundamental requirement to establish a uniform cooling from top to bottom work rolls and transversely across the cooling area resulting in an optimal heat extraction across the spray cooling area on the roll.

When designing a spray header Lechler arranges the sprays without interference or creating hot and cool bands in adjacent cooling zones. The nozzle flow rates and spray angles are taken into account besides the positions of the spray headers in the mill for the design of the optimal nozzle offset and impingement angles in order to obtain the best heat transfer.

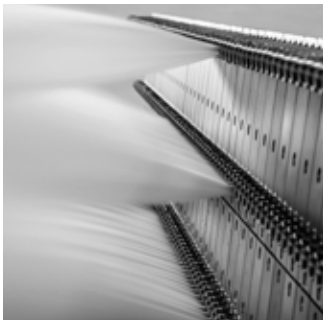

## Lechler SELECTOSPRAY® valves

The proven Modulax valve design is available in three different versions:

- Pneumatically controlled with the solenoid in the control cabinet outside of the mill
- Electro-pneumatically with the solenoid directly attached (DSA)
- Purely electrically controlled (EVA)

All valve versions have very large coolant entry ports, are easily removable from the header front and are protected by the header itself. All valves carry self-aligning flat jet nozzles.

## Lechler SELECTOSPRAY® valves (MODULAX)



- Liquid to air pressure ratio 2:1
- Very large internal free passages
- Uses standard shop air
- Simple design, only one moving part which is the piston



## Electro-pneumatic valve actuation (DSA)



- Each valve has its own dedicated solenoid directly attached
- Shorter response time
- Air for the pilot operation is fed by a single tube directly into the header and instantly available when the electrical solenoid is activated
- Solenoids can be supplied in either normally open or normally closed

## Electric valve actuation (EVA)



- Especially in rolling mills where inflammable rolling oil or kerosene is used as a coolant and without the need for compressed air
- Large orifices for a laminar flow and a stable spray

# Accessories

## Series 6F

Weight brass .13lbs

Retaining nut: **065. 600. 11** (AISI 430 F)  
**065. 600. 16** (303 SS)  
**065. 600. 17** (316 SS)  
**065. 600. 30** (brass)

Weight .18 lbs

Welding nipple: **06F. 410. 17. xx** (316 SS)  
**06F. 411. 17. xx** (316 SS)

$L_2 = L_1 + .55$  in

## Series 6F

**Nipple length .79-3.90 in**  
in steps of 1 mm

Basic type number	Length $L_1$
<b>06F. 410. 17</b>	<b>xx</b>
<b>xx = nipple length [mm]</b>	
Example for nipple length 1.38 in <b>06F. 410. 17.</b>	<b>1.38</b>

**Nipple length 3.94-7.83 in**  
in steps of 1 mm

Basic type number	Length $L_1$
<b>06F. 411. 17</b>	<b>xx</b>
<b>xx = nipple length [mm]</b>	
Example for nipple length 1.38 mm <b>06F. 411. 17.</b>	<b>1.38</b>

## Series 660

Weight .06 lbs

Retaining nut: **065. 200. 16** (303 SS)  
**065. 200. 17** (316 SS)  
**065. 200. 30** (brass)

Weight .05 lbs

Welding nipple: **066. 011. 17** (316 SS)

1.08

**Other nipple lengths for all nozzle series on request.**

## Alignment tips

- Series 6E: **06E.490.1Y**
  - Series 6F: **06F.490.1Y**
  - Series 660: **066.090.16**  
offset angle 5°
  - Series 664/665: **066.490.16**  
offset angle 15°
  - Series 669: **066.990.16**  
offset angle 15°
- (other offset angles on request)

## Series 664/665

Weight brass .13lbs

Retaining nut: **065. 600. 11** (AISI 430 F)  
**065. 600. 16** (303 SS)  
**065. 600. 17** (316 SS)  
**065. 600. 30** (brass)

Weight .14 lbs

Welding nipple: **066. 410. 17** (316 SS)  
**066. 410. 03** (1.0570)

1.50

## Series 669

Weight brass .45 lbs

Retaining nut: **066. 900. 16** (303 SS)  
**066. 900. 17** (316 SS)  
**066. 900. 30** (Brass)

Weight .62 lbs

Welding nipple: **066. 910. 17** (316 SS)  
**066. 910. 02** (1.0159)

2.24

# YOU CAN FIND MORE NOZZLES IN OUR STANDARD CATALOG ...

The catalog "Precision Spray Nozzles and Accessories" is a sought-after manual of nozzle technology.

It contains valuable working aids and extensive technical information on Lechler products and ordering instructions.



## ... AND IN OUR SPECIAL BROCHURES

We have a collection of information, included in individual subject brochures, covering special nozzles that are also of particular interest to roll cooling. All documents can be downloaded from our website at [www.lechlerusa.com](http://www.lechlerusa.com).

We would also be happy to send you the brochures.



## Yes, I want to get detailed information on Lechler products

Please send me the special information:

- Catalogue »Precision Spray Nozzles and Accessories«
- Brochure »Continuous Casting«
- Brochure »SELECTOSPRAY® Roll Cooling Systems«
- Brochure »Selectospray Pneumatic Roll Cooling System«
- Brochure »Selectospray Electropneumatic Roll Cooling System«
- Brochure »SCALEMASTER HPS®«
- Brochure »SCALEMASTER® HP«
- Brochure »Pickling lines«
- Brochure »MicroSCALEMASTER®«

Special interests:

---



---

Our Address:

Name

Company/Department

P.O. Box/Street

Postcode/City

Country

Phone

E-mail

ENGINEERING  
YOUR SPRAY SOLUTION



## LECHLER WORLD-WIDE

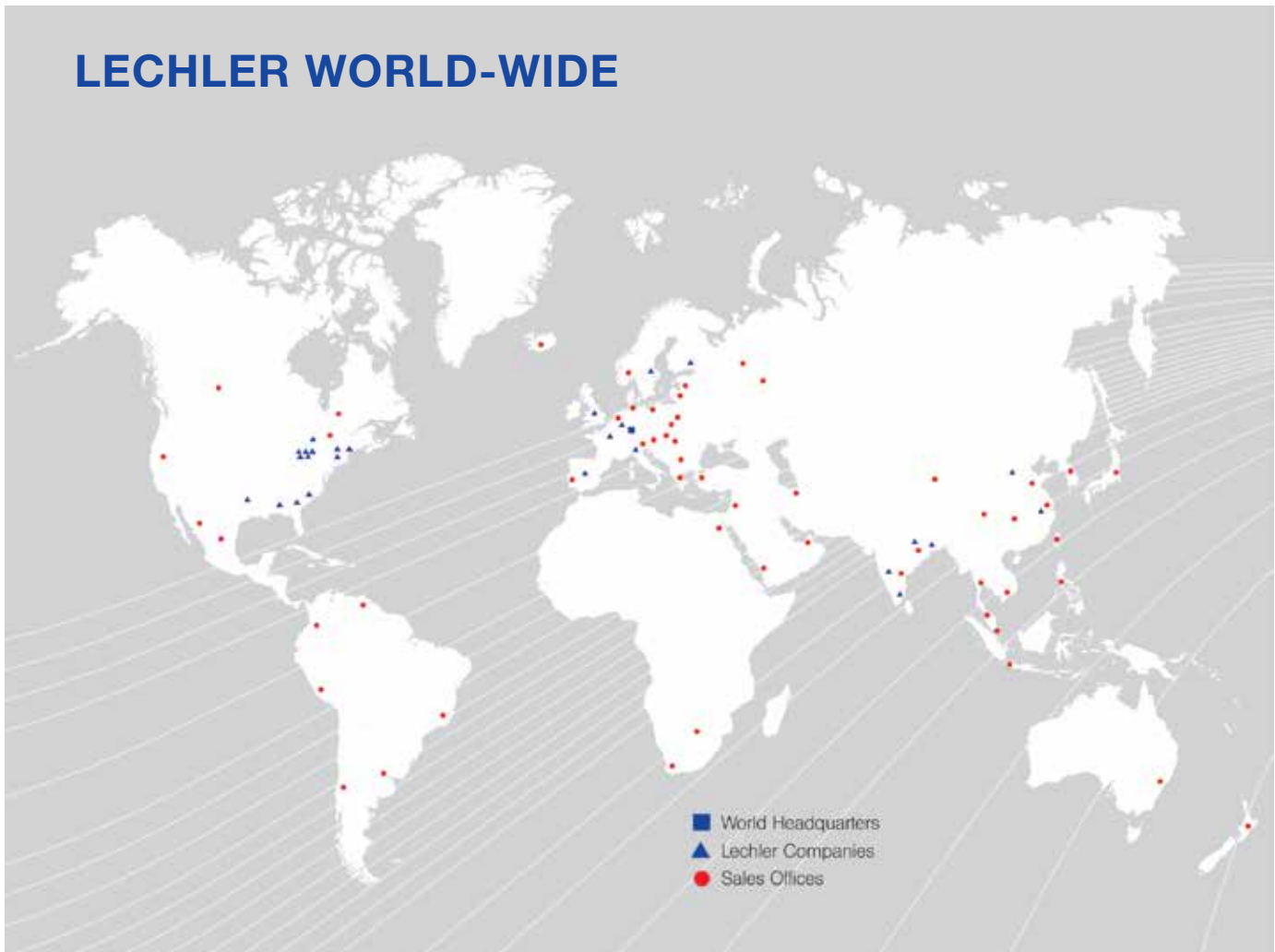

Edition 10/19 - USA - Subject to technical modification

### Lechler, Inc. · Precision Nozzles · Nozzle Systems

445 Kautz Road, St. Charles, IL 60174 · Phone (800) 777-2926 · Fax (630) 377-6657 · [info@LechlerUSA.com](mailto:info@LechlerUSA.com) · [www.LechlerUSA.com](http://www.LechlerUSA.com)

**ASEAN:** Lechler Spray Technology Sdn. Bhd. · No. 23, Jalan Teknologi 3/3A · Taman Sains Selangor 1 · Kota Damansara, PJU 5 · 47810 Petaling Jaya · Malaysia · [info@lechler.com.my](mailto:info@lechler.com.my)

**Belgium:** Lechler S.A./N.V. · Avenue Mercator, 6 · 1300 Wavre · Phone: +32 10 225022 · Fax: +32 10 243901 · [info@lechler.be](mailto:info@lechler.be)

**China:** Lechler Intl. Trad. Co. Ltd. · Beijing · Rm. 418 Landmark Tower · No. 8 Dong San Huan Bei Lu · Phone: +86 10 84537968, Fax: +86 10 84537458 · [info@lechler.com.cn](mailto:info@lechler.com.cn)

**Finland:** Lechler Oy · Jäspiänkatu 18 · 04250 Kerava · Phone: +358 207 856880 · Fax: +358 207 856881 · [info@lechler.fi](mailto:info@lechler.fi)

**France:** Lechler France, S.A. · Bât. CAP2 · 66-72, Rue Marceau · 93558 Montreuil · Phone: +33 1 49882600 · Fax: +33 1 49882609 · [info@lechler.fr](mailto:info@lechler.fr)

**Germany:** Lechler GmbH · PO Box 13 23 · 72544 Metzingen · Phone: +49 7123 962-0 · Fax: (49) 7123 962-444 · [info@lechler.de](mailto:info@lechler.de)

**Great Britain:** Lechler Ltd. · 1 Fell Street, Newhall · Sheffield, S9 2TP · Phone: +44 114 2492020 · Fax: +44 114 2493600 · [info@lechler.com](mailto:info@lechler.com)

**India:** Lechler (India) Pvt. Ltd. · Plot B-2 · Main Road · Wagle Industrial Estate · Thane (W) · 400604 · Phone: +91 22 40634444 · Fax: +91 22 40634498 · [lechler@lechlerindia.com](mailto:lechler@lechlerindia.com)

**Italy:** Lechler Spray Technology S.r.l. · Via Don Dossetti, 2 · 20080 Carpiano (MI) · Phone: +39 02 98859027 · Fax: +39 02 9815647 · [info@lechleritalia.com](mailto:info@lechleritalia.com)

**Spain:** Lechler S.A. · Avda. Pirineos 7 · Oficina B7, Edificio Inbisa I · 28700 San Sebastián de los Reyes, Madrid · Phone: +34 91 6586346 · Fax: +34 91 6586347 · [info@lechler.es](mailto:info@lechler.es)

**Sweden:** Lechler AB · Kungsängsvägen 31 B · 753 23 Uppsala · Phone: +46 18 167030 · Fax: +46 18 167031 · [info@lechler.se](mailto:info@lechler.se)