

ENGINEERING
YOUR SPRAY SOLUTION



PRECISION SPRAY NOZZLES AND ACCESSORIES

for industrial spray solutions | Edition 600



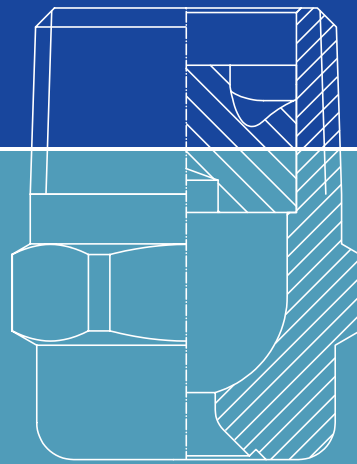









INDUSTRY





INDUSTRIAL NOZZLE TECHNOLOGY FROM THE LEADING SUPPLIER

CONTENTS

	Introduction	4
	Planning aids	27
	Engineering and Fabrication	46
	Tank cleaning nozzles	53
	Pneumatic atomizing nozzles	107
	Hollow cone nozzles	145
	Full cone nozzles	163
	Flat fan nozzles	189
	Solid stream nozzles	250
	Compressed air nozzles	264
	Nozzle-valve combinations	285
	Accessories	295
	STAMM Showers	321

Index of parts by nozzle series

Nozzle Series	Description	Page
Accessories		301
	Part numbers starting with 061, 062, 065, 066, 069, 090, 091, 092, 095	
013	AirMist Accessories	129
017	ViscoMist Replacement Kits	144
05C	Hygienic Fit Adapter	103
050	Rotation Monitoring Sensor	102
099	Screens for Trimming Nozzles	261
10.xxx	STAMM® Linear Oscillators	325
136.1	AirMist Internal Mix Full Cone	115
136.2	AirMist Internal Mix Wide Angle Full Cone	117
136.3	AirMist External Mix Full Cone	118
136.4	AirMist Internal Mix Wide Angle Flat Fan	121
136.5	AirMist Internal Mix Wide Flat Fan	123
136.6	AirMist External Mix Flat Fan	125
140	Pneumatic Atomizing Full Cone	138
166.1	Pneumatic Atomizing Full Cone	131
166.2	Pneumatic Atomizing Wide Full Cone	133
166.4	Pneumatic Atomizing Flat Fan	134
166.6	Pneumatic Atomizing Flat Fan	136
176	ViscoMist	139
214/216/218	Axial-Low Flow Hollow Cone	153
220	Axial-Low Flow Hollow Cone	151
226	Axial-Low Flow Hollow Cone Tip	152
2TR	Axial Hollow Cone, Tip	154
302	Tangential-Flow Hollow Cone SS/Brass	155
302	Tangential-Flow Hollow Cone Plastic	156
302	Tangential-Flow Hollow Cone Plastic TWISTLOC	158
304/306/307	Tangential-Flow Hollow Cone	160
308	Tangential-Flow Hollow Cone	159
350	Tangential-Flow Hollow Cone	161
373	Ramp Bottom Hollow Cone	162
403	Axial Full Cone	178
405	Axial Full Cone	176
419	Axial Full Cone	179
422	Vaneless Full Cone, Plastic TWISTLOC	186
422/423	Vaneless Full Cone, Metal	181
422/423	Vaneless Full Cone, Plastic	184
452	Injector Narrow Full Cone	175
459	CenterJet Full Cone	177
460/461	Axial Full Cone Plastic	169
468	Axial Full Cone Tip	174
485	Axial Full Cone	180
490/491	Axial Full Cone Metal	171
500.186	MiniWhirly	72
500.191	PVDF Micro Whirly	73
500.234	PicoWhirly	69
500.262/428	Eductor	259
502/503	Cluster Head Full Cone	187
524/525	Deflector Plate Nozzle	188
527	Static Sanitary Spray Ball	65
540/541	Static Spray Ball	66
540/541	Air or Steam Cluster Solid Stream	284
544	Solid Stream Threaded	255
544	Air or Solid Stream	283
546	High Pressure Solid Stream	256
548	High Pressure Solid Stream Tip	257
550	High Pressure Solid Stream	256
564	Easy Flush	238
566	Stainless Steel Micro Whirly	70
5W9	Whirly 2	88
573/583	PTFE Whirly	82
577	Gyro Tank Cleaner	90
594/595	Hygienic Whirly	86
597	Lauter Tun	100
599.009/599.028	Needle Jet	260
599.040	High Pressure Solid Stream	262
599.128	Trimming	261
5B2/5B3	Rinse Clean	68
5M1	NanoSpinner 2	74
5M2	MicroSpinner 2	76
5M3	MiniSpinner 2	78
5M4	MaxiSpinner 2	80
5P2/5P3	PopUp Whirly	84
5P5	PopUp Clean	101
5TB	IntenseClean Tank Cleaning Machine	97
5TM	High Impact Tank Cleaning Machine	98
5S6/5S7	XactClean HP2	91
5S5	XactClean HP+	93
5T2/5T3	MeshClean	95
600.130.56/S2	WHISPERBLAST Flat Plastic	269
600.484	WHISPERBLAST Flat Plastic	270
600.130.1Y	WHISPERBLAST Flat Stainless Steel	271
600.130.283/606	WHISPERBLAST Flat Aluminum	272
600.493	WHISPERBLAST Flat Stainless Steel	273
600.562	WHISPERBLAST Compact Stainless Steel	274
600.326/725	Mult Channel Round Jet Air Plastic	279
600.326.3W	Mult Channel Round Jet Air Zinc	280
600.388	Mult Channel Round Jet Air Brass	281
600.625	Mult Channel Round Jet Air Stainless Steel	282
610	Low Pressure Flat Fan	202
612	Low Pressure Flat Fan	204
616/617	Low Pressure Flat Fan	207
612.XXX.53.03	Low Pressure Flat Fan Press Fit	209
602	High Pressure Flat Fan	232
608	High Pressure Flat Fan	233
652	High Pressure Flat Fan Tip	234
6FH	High Pressure Flat Fan with Stabilizer	235
626/5SW	STAMM® Shower Nozzles	324
632/633	Flat Fan Threaded Low Pressure Flat Fan	199
646	Low Pressure Flat Fan Bayonet Tip	239
652	Low Pressure Flat Fan Tip	212
652.xxx.8H.03	Flat Fan for Conveyer Lubrication	237
656/657	Roto Fan Flat Fan Tip	215
660	Dovetail Flat Fan Tip	226
664/665	Dovetail Flat Fan Tip	229
672/673	Flat Fan Press Fit	210
676	Flat Fan with Ball Joint	224
676	Easy Clip Assembly	245
676/677	MEMOSPRAY	241
679	Blow Off Tip	275
680	Flat Fan Disc Threaded	221
690	Flat Fan Disc	222
684	Deflector Wide Angle Flat Fan Tip	217
686	Deflector Wide Angle Flat Fan Tip	218
686	Air or Steam Deflector	277
688/689	Impactor Flat Fan	220



WHERE TRADITION MEETS THE FUTURE



1879

Company founded by Paul Lechler

1893

Patent for liquid atomization

1967

Relocation of production to Metzingen

1978

Expansion to the USA and then to other countries

1995

Production, sales and administration are concentrated in Metzingen



140

1879 - 2019

2010

Expansion of production with a new 13.000 m² Manufacturing Plant

2016

New Development and Technology Center is opened in Metzingen

2019

Celebrating 140 years

2021

New factory in China

2022

New logistics center in Metzingen



THERE ARE MANY REASONS TO CHOOSE NOZZLES FROM LECHLER

The first choice for your nozzle solution

You only become a market leader and Europe's number one in nozzle technology when you can offer your customers a variety of engineered spray solutions. Lechler embodies our relationships with customers on every level.

Unrivalled product diversity

Boasting over 45,000 different nozzles and nozzle systems, Lechler is able to solve the challenges of virtually every process in every industry. If there is not a product for you in our portfolio, Lechler will develop solutions working with our customers and their requirements.

Over 140 years of experience

Lechler has been atomizing liquids since 1879. Today, we understand spray technology better than anyone else. With this experience, we not only develop the perfect nozzle for each application, but also offer expert advice on optimising spraying processes.

State of the Art Manufacturing

Whether you are looking for state-of-the-art metal processing, precision injection moulding, metal injection molding (MIM), ceramic sintering or 3D printing: We have the experience and knowledge to offer all manufacturing techniques.

Measurement Technology Center

In our globally incomparable development and technology center, we analyze the spray behavior of our nozzles. Equipped with cutting-edge test rigs, highly developed nozzle measurement technology and state of the art infrastructure, Lechler's research and development center offers various opportunities that serve all of our customers needs; from practical testing, droplet analysis, measurement technology, and more.

Highly qualified employees

Employee management at Lechler is characterized by the promotion of continuous development and team spirit in the workplace. This is the secret recipe behind our companies success and true passion and commitment of our people throughout the organization.

Creating Solutions

The needs and requirements of our customers are at the forefront of everything we do. Our goal is to always offer the ideal solution for every task, and if it is not yet available, we develop it.

Long Lasting Customer Relationships

Longevity and quality is the foundation to which our business is built upon. We thrive on mutual trust and attach great importance to excelling through performance, know-how and long-term partnerships.





GERMAN ENGINEERING GLOBAL MARKET LEADER



Headquarters

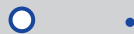

Subsidiary



Sales office/
Sales agent

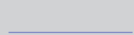

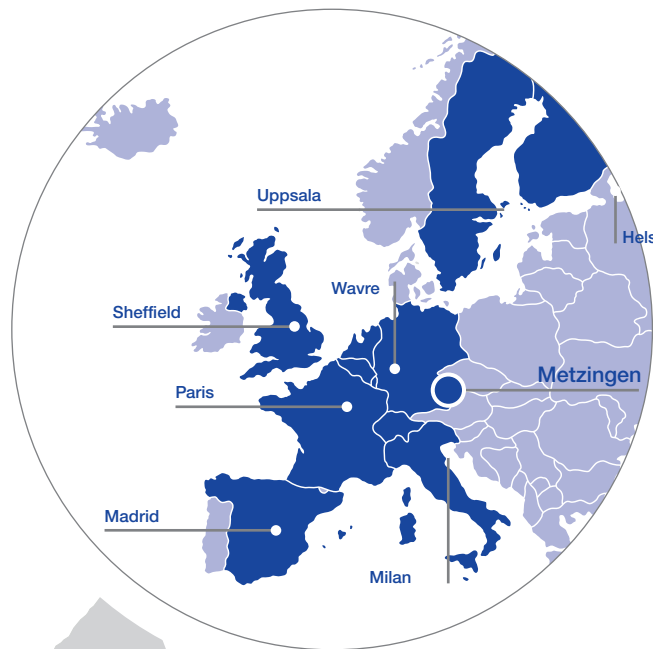

- Subsidiary
- Sales office/ Sales agent



 **Headquarters**

 **Production**

 **Sales**



Germany
 Lechler GmbH
 Ulmer Strasse 128
 72555 Metzgingen
 Phone +49 7123 962-0
 info@lechler.de



USA
 Lechler Inc.
 445 Kautz Road
 St. Charles, IL 60174
 Phone +1 630 3776611
 info@lechlerusa.com



India
 Lechler (India) Pvt. Ltd.
 Plot B-2
 Main Road
 Wagle Industrial Estate Thane
 400604 Maharashtra
 Phone +91 22 40634444
 lechler@lechlerindia.com



China
 Lechler Nozzle Systems
 (Changzhou) Co., Ltd.
 No.99 Decheng Rd, Jintan
 Changzhou, JS 213200, P.R.C
 Phone +86 519-6822 8088
 info@lechler.com.cn



ASEAN
 Lechler Spray Technology
 Sdn. Bhd.
 No. 22, Jalan Astaka 4B/KU2
 Bandar Bukit Raja
 41050 Klang, Selangor
 Malaysia
 Phone +603 3343 0888
 info@lechler.com.my



Belgium
 Lechler S.A./N.V.
 Avenue Newton 4
 1300 Wavre
 Phone +32 10 225022
 info@lechler.be



Finland
 Lechler Oy
 Ansatie 6 a C 3 krs
 01740 Vantaa
 Phone +358 207 856880
 info@lechler.fi



France
 Lechler France SAS
 Bât. CAP2
 66-72 Rue Marceau
 93100 Montreuil
 Phone +33 1 49882600
 info@lechler.fr



Great Britain
 Lechler Ltd.
 1 Fell Street, Newhall
 Sheffield, S9 2TP
 Phone +44 114 2492020
 info@lechler.com



Italy
 Lechler Spray Technology S.r.l.
 Via Don Dossetti, 2
 20080 Carpiano (MI)
 Phone +39 2 98859027
 info@lechleritalia.com



Spain
 Lechler, S.A.
 C / Isla de Hierro, 7 –
 Oficina 1.3
 28703 San Sebastián de los
 Reyes (Madrid)
 Phone +34 91 6586346
 info@lechler.es



Sweden
 Lechler AB
 Kungsängsvägen 31B
 753 23 Uppsala
 Phone +46 18 167030
 info@lechler.se

DIVERSITY IN TOP FORM

Lechler's services go far beyond the development and production of nozzles. Thanks to an extensive portfolio of products and services, we are able to ensure optimum spraying results in a wide range of industries and applications.

MEASURING TECHNOLOGY

At Lechler, high-precision spray measurements and analysis are not only used for nozzle developments, they are also offered as a service.



For detailed information about
our range of services, please visit:
www.lechlerusa.com

NOZZLES

In addition to the nozzles presented in this catalogue, our portfolio also includes numerous special nozzles – for applications in many other industries, from agriculture to steel production.

CFD

Computational Fluid Dynamics (CFD) not only enables us to develop nozzles quickly and precisely, it also ensures customer-specific process optimization.

ENGINEERING

Our experienced engineering team strives to provide you with a system solution tailored to your application and installation-specific conditions.



DROPLET SEPARATORS

Our droplet separators play a key role in process optimizations. They are primarily designed to separate liquids from gas flows and are currently used in over 100 different applications worldwide.

LANCES AND CUSTOM SOLUTIONS

With custom nozzle lances, spray headers and spray systems, we ensure the implementation of customized solutions for your specific application.

➤➤ FOUR BUSINESS DIVISIONS DIVERSITY AT ITS FINEST

There's more to spraying than meets the eye. Various industries have their own focus and requirements. To meet all of them, we develop and sell industry-oriented solutions in four individual business sectors.

Our diversity and experience spanning over 140 years gives us a wealth of knowledge that is shared to guarantee the best engineered spray solution across all industries.



GENERAL INDUSTRY

Food and Beverage Industry, Pharmaceutical Industry, Chemical Industry, Automotive Industry, just to name a few. Lechler Nozzles can be found in almost every production environment. With a deep understanding of customer processes, we ensure an optimized engineered spray solution for every application.



AGRICULTURE

From plant protection and liquid fertilization to irrigation – Lechler offers the ideal nozzles for precise application, thereby achieving the best results with minimal effort in the shortest possible time. This helps to increase yields and protect the environment.



METALLURGY

Steel and aluminium producers face immense competitive pressure worldwide. The required product qualities can only be produced with maximum energy efficiency through optimization of your process.

Lechler nozzles make a decisive contribution to producing innovative material grades and reducing CO₂ emissions.



AIR QUALITY CONTROL SYSTEMS

Increasingly stringent emission requirements but also a growing number of voluntary commitments mean air quality control systems are in the spotlight more than ever. With its wide range of nozzles and efficient gas treatment systems, Lechler offers the perfect answer for every application.

»» AT HOME IN MANY INDUSTRY SECTORS

We understand your processes and engineer every solution to match each nozzle to the respective environmental conditions. Our specialists will help you choose the right nozzle and aid in engineering services to meet your application needs.

APPLICATIONS



CLEANING
REMOVING
COOLING
SURFACE TREATMENT
SURFACE SPRAYING
ATOMIZING
MIXING

AUTOMOTIVE INDUSTRY



CHEMICAL INDUSTRY



ELECTRONICS INDUSTRY

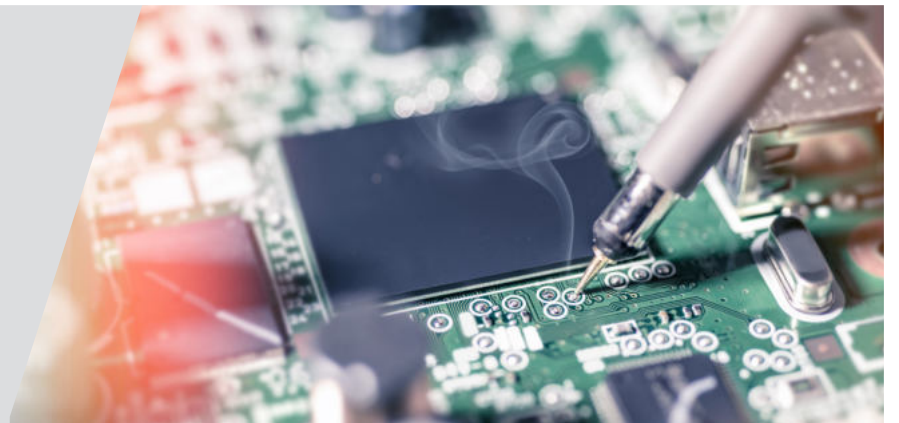



**INDUSTRIAL
CLEANING TECHNOLOGY**



**FOOD AND
BEVERAGE INDUSTRY**



SURFACE TREATMENT



**PHARMACEUTICAL AND
COSMETICS INDUSTRY**



**SHIPBUILDING INDUSTRY
AND MANY MORE ...**

➤➤ A BRIEF INTRODUCTION
TO MORE THAN
45,000 PRODUCTS

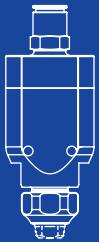
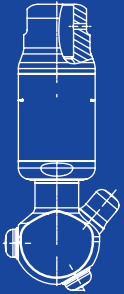
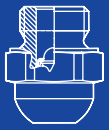





QUESTION OF SHAPE: THE IDEAL SPRAY PATTERN FOR YOUR APPLICATION

Form follows function – and vice-versa. The search for the right nozzle begins with the choice of atomization type (single fluid nozzle or pneumatic atomizing nozzle) and the appropriate spray pattern. This determines the essential properties of the nozzle.

Single fluid nozzle

By narrowing the cross section in the nozzle, the flow velocity of the fluid being atomized increases. Potential energy is converted into kinetic energy (speed). The fluid exiting the nozzle orifice disburse the liquid into droplets of various sizes and distribution.

Solid stream nozzles



Flat fan nozzles

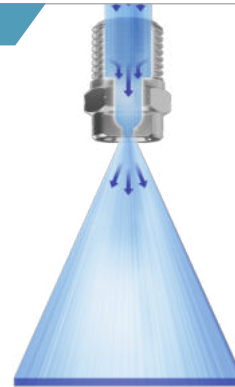

Defined spray, linear impact. A wide range of nozzles with various flow rates, spray angles and materials.

Main applications:

- Cleaning
- Coating
- Humidification

Hollow cone nozzles

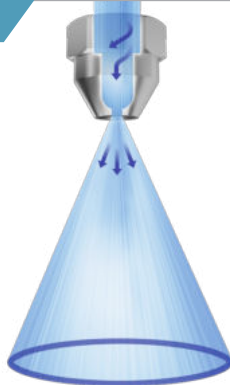

Ring-shaped impact, various flow rates and fine atomization. Available in two designs (axial and tangential).

Main applications:

- Cooling
- Humidification
- Chemical engineering

Full cone nozzles

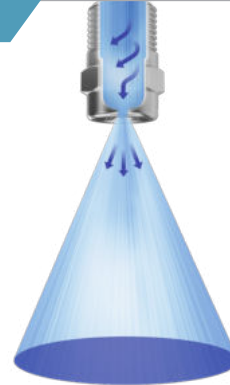

A wide range of nozzles with full surface impact. Available in two designs (axial and tangential).

Main applications:

- Cleaning
- Surface spraying
- Chemical engineering

Pneumatic atomizing nozzles

With pneumatic atomization, the various flow velocities of gases and liquids in a nozzle result in the desired shearing of the liquid into extremely fine droplets.



Finest atomization even of viscous fluids. Full cone or flat fan versions are available.

Main applications:

- Cooling
- Humidification
- Chemical engineering

Compressed air nozzles

Compressed air nozzles are used for dispersing air or saturated steam in a concentrated fan. Generally, they are flat fan, solid stream or round jet nozzles. Our multi-channel compressed air nozzles are extremely quiet and also economical in terms of air consumption.



High blowing force with maximum efficiency and reduced noise level.

Main applications:

- Blowing off and out
- Cooling
- Drying

Tank cleaning nozzles

For years now, our tank cleaning nozzles have been making a name for themselves as both an economical and highly effective solution for tank and equipment cleaning. The portfolio is divided into static spray balls and rotating cleaning nozzles.

Static nozzles

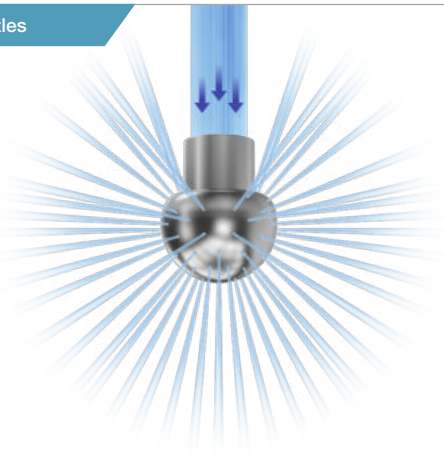

Extremely robust version for easy rinsing even at high temperatures.

Rotating nozzles

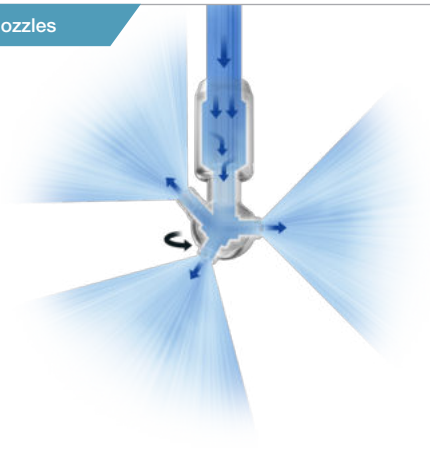

High cleaning performance in the low pressure range for any amount of soiling. Enables cleaning in place and saves on expensive cleaning chemicals.



OVERVIEW OF KEY NOZZLE PARAMETERS



FLOW RATE

TEMPERATURE

LIQUID

PRESSURE



In addition to the spray pattern, each nozzle has specific properties, which in turn depend on various – mutually influencing – operating parameters. An overview of the key factors can be found in the planning aids section starting on Page 27.

IMPACT

SPRAY ANGLE

DROPLET SIZE

LIQUID DISTRIBUTION

OUR PRODUCT NUMBERS: EVERYTHING YOU NEED TO KNOW IN TEN CHARACTERS

Each Lechler product number not only serves as an order number, it also describes all the essential properties of the associated nozzle.

Product number

632.301.16.BA

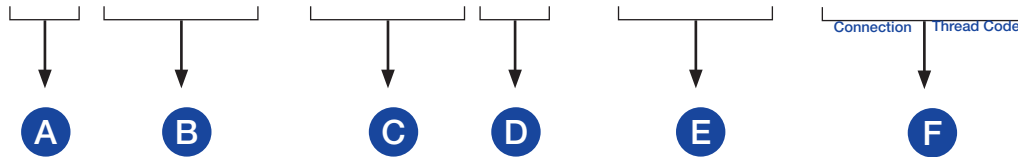

A SPRAY PATTERN

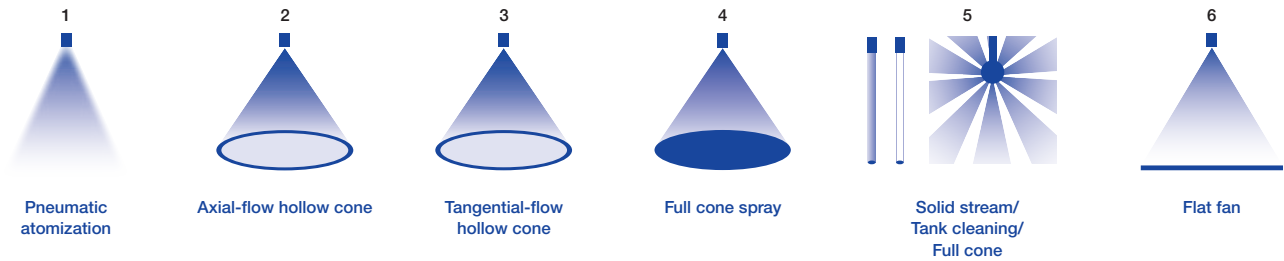

B NOZZLE TYPE/SERIES

C FLOW RATE



The flow rate depends on the respective nozzle type. The exact specifications are shown in the tables on the product pages. The values refer to the measurement with water.

D SPRAY ANGLE



Flat fan: 1 = 20°, 2 = 30°, 3 = 45°, 4 = 60°, 5 = 75°, 6 = 90°, 7 = 120°
Hollow and full cone: 3 = 45°, 4 = 60°, 5 = 70/80°, 6 = 90°, 8 = 120°/130°, 9 = 180°
Solid stream: 0 = 0°

E MATERIAL



11 = Stainless Steel 430F, 1Y = Stainless Steel 316L, 16 = Stainless Steel 303, 17 = Stainless Steel 316/316Ti, 30 = Brass, 5E = PVDF, 51 = PA, 53 = PP, 55 = PTFE, 56 = POM, 42 = aluminum.

For individual series, the material may deviate from this numbering system. Refer to the respective product page for details. Special material available on request.

F CONNECTION



A=BSPP Connection
B=NPT Connection
C=BSPT Connection

THREAD CODE

male		female	
A	= 1/8"	B	= 1/8" D
C	= 1/4"	F	= 1/4"
E	= 3/8"	H	= 3/8"
G	= 1/2"	L	= 1/2"
K	= 3/4"	N	= 3/4"
M	= 1"	Q	= 1"
P	= 1 1/4"	S	= 1 1/4"
R	= 1 1/2"	W	= 1 1/2"
V	= 2"	Z	= 2"
Y	= 2 1/2"	MB	= 2 1/2"
MA	= 3"	MF	= 3"
ME	= 4"	MH	= 4"
MG	= 5"	ML	= 5"
MK	= 6"		= 6"

Spray angle	Ordering number								Equivalent bore diameter A [in]	Narrowest free cross section of the nozzle Ø [in]	V̇ water [gal/min]								Spray width B [in] (at p = 75 psi)		
	Type	Material number				Connection					p [psi]										
		16 ¹	17 ²	30	5E	1/8 NPT	1/4 NPT	3/8 NPT			1/2 NPT					liters per minute	5 bar	100			145
		Stainless steel 303/ Stainless steel 304	Stainless steel 316Ti/ Stainless steel 316L	Brass	PVDF							7	15	30	45				75		
20°	632.301	●	●	●	●	BA	BC			0.03	0.02	0.04*	0.06*	0.09	0.11	0.14	0.51	0.16	0.19	3	6
	632.361	●	●	●	●	BA	BC			0.04	0.03	0.08*	0.12*	0.17	0.21	0.27	1.00	0.31	0.37	3	6
	632.441	●	●	●	●	BA	BC			0.05	0.04	0.16*	0.24	0.34	0.41	0.53	1.98	0.61	0.74	3	6
	632.481	●	●	●	●	BA	BC			0.06	0.05	0.21*	0.30	0.43	0.53	0.68	2.53	0.78	0.95	3	6
30°	632.302	●	●	●	●	BA	BC			0.02	0.02	0.04*	0.06*	0.09	0.11	0.14	0.51	0.16	0.19	5	9
	632.362	●	●	●	●	BA	BC			0.04	0.03	0.08*	0.12*	0.17	0.21	0.27	1.00	0.31	0.37	5	9

* All the nozzles are designed for a specific reference pressure. This pressure is highlighted in bold in the tables on the product pages. The flow rate specifications at the reference pressure are measured values. The flow rate specifications for a deviating pressure level are calculated values.

Ordering examples

- You are looking for a flat fan nozzle with a 20° spray angle and an approx. 0.9 gal/min flow rate at 30 psi. It should be made of stainless steel 303 and come with a 1/8" male thread.

Type	+	Material no.	+	Code	=	Ordering no.
632.301	+	16	+	BA	=	632.301.16.BA

- You are looking for a flat fan nozzle with a 30° spray angle and an approx. 0.21 gal/min flow rate at 45 psi. It should be made of brass and come with a 1/4" male threaded connection.

Type	+	Material no.	+	Code	=	Ordering no.
632.362	+	30	+	BC	=	632.362.30.BC

Information on dimensions

- All dimensions in technical drawings and tables are in inches (unless stated otherwise).
- Thread sizes BSPP and NPT are given in inches.

Product images

The images on the product pages are provided as examples and may deviate in individual cases depending on the actual nozzle size.

▶▶ PLANNING AIDS

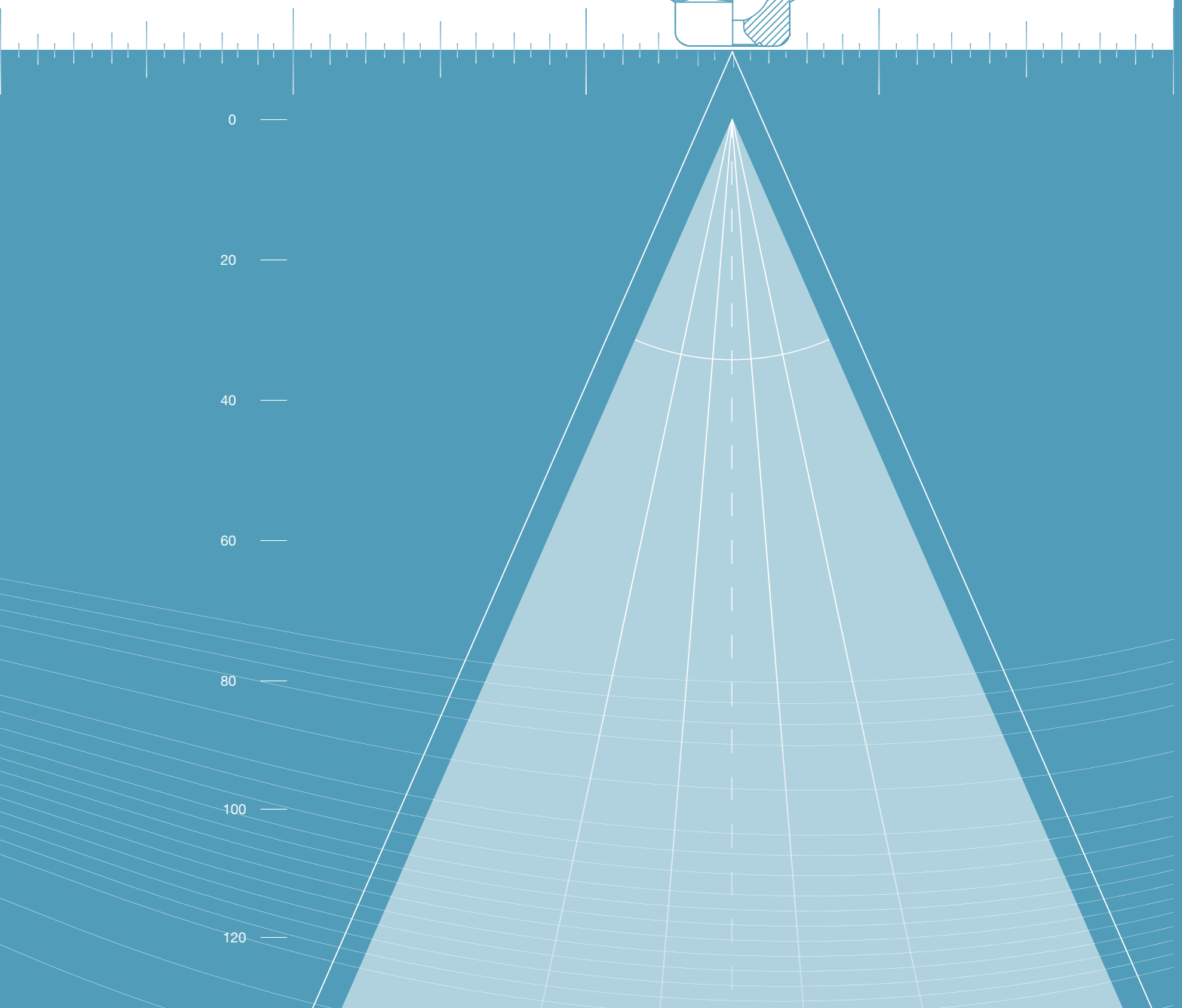
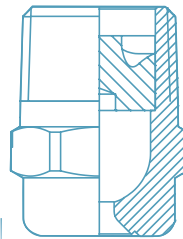

»» PLANNING AIDS YOU CAN COUNT ON OUR SUPPORT



To achieve the optimum spray pattern for your application, numerous influencing factors must be taken into account. The following provides an overview of the key parameters. Needless to say, we will be more than happy to help you find the ideal nozzle.

- Flow rate
- Droplet size
- Spray angle
- Viscosity
- Impact
- Nozzle arrangement
- Determination of the pipe diameter
- Conversion tables
- Lechler online services
- Certificates and declarations





Flow rate via pressure

With single element nozzles, the flow rate is controlled exclusively via the connection pressure.
The following correlation applies:

	Axial-flow full cone nozzles	All other single element nozzles
Calculation of the flow rate \dot{V} [l/min] at a given pressure p [bar]	$\dot{V}_2 = \left(\frac{p_2}{p_1}\right)^{0,4} \cdot \dot{V}_1$	$\dot{V}_2 = \sqrt{\frac{p_2}{p_1}} \cdot \dot{V}_1$
Calculation of the pressure p [bar] at a given flow rate \dot{V} [l/min]	$p_2 = \left(\frac{\dot{V}_2}{\dot{V}_1}\right)^{2,5} \cdot p_1$	$p_2 = \left(\frac{\dot{V}_2}{\dot{V}_1}\right)^2 \cdot p_1$

Flow rate via pressure

Pressure-flow rate chart for two single element nozzles

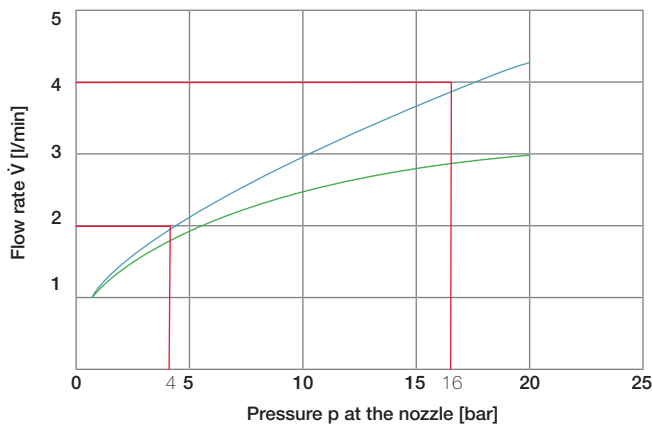

- Flow rate axial-flow full cone nozzle
- Flow rate of all other single element nozzles

All pressure values refer to the difference Delta p between the connection pressure and the ambient pressure.

$$\Delta p = p_1 - p_2$$



To double the flow rate, four times the connection pressure is, thus, required for all single element nozzles, except for axial-flow full cone nozzles.

Flow rate as a function of the medium density

For media with a lower density than water, the volume rate increases.

$\dot{V}_w = \frac{\dot{V}_{F1}}{X}$	\dot{V}_w = flow rate of water [l/min, l/h]
$\dot{V}_{F1} = \dot{V}_w \sqrt{\frac{\rho_w}{\rho_{F1}}} = \dot{V}_w \cdot X$	\dot{V}_{F1} = flow rate of the liquid whose density deviates from 1,000 [kg/m ³]
$X = \sqrt{\frac{\rho_w}{\rho_{F1}}}$	X = multiplier ρ = density [kg/m ³]
P_{F1}	500 600 700 800 900 1,000 1,100 1,200 1,300 1,400 1,500 1,600 1,700 1,800 1,900 2,000
X	1.41 1.29 1.20 1.12 1.06 1.00 0.95 0.91 0.88 0.85 0.82 0.79 0.77 0.75 0.73 0.71

PLANNING AIDS

DROPLET SIZE



Each nozzle produces a spray of differently sized droplets (poly-disperse spray). For many applications (e.g. evaporative cooling, absorption processes), the size of the total surface area of all the droplets is crucial. The Sauter mean diameter (D_{32}) was defined for this reason.

If you transform the total volume of the droplets of a spray into droplets of equal size, which in sum would have the identical volume/surface ratio as the actual spray, these droplets would have the Sauter mean diameter.

Monodisperse spray (Quite rare in reality)

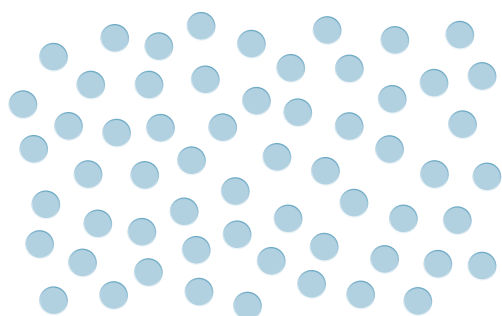

Typical droplet distribution of the spray of a single element nozzle

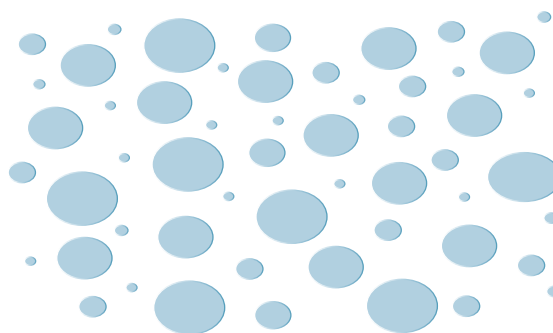

The sprays have varying droplet sizes. However, the ratio of surface area to volume is the same for both and thus also their Sauter mean diameter.

Rough classification of droplet sizes

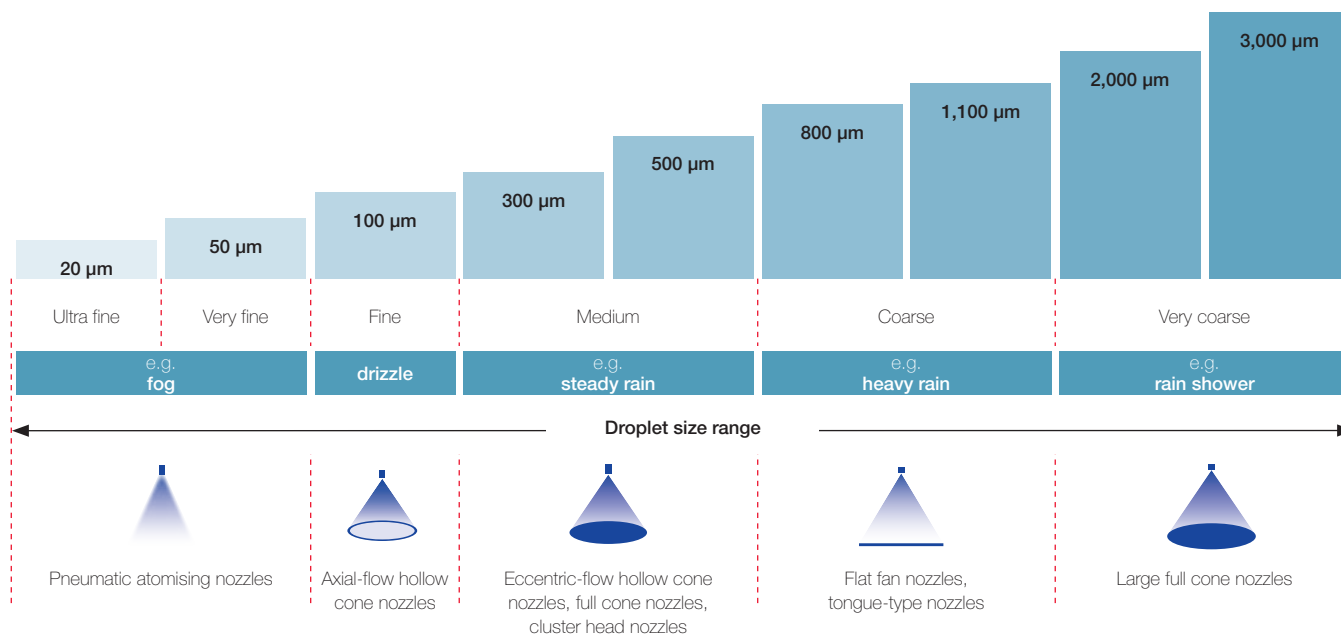



Droplet diameter as a function of the operating pressure

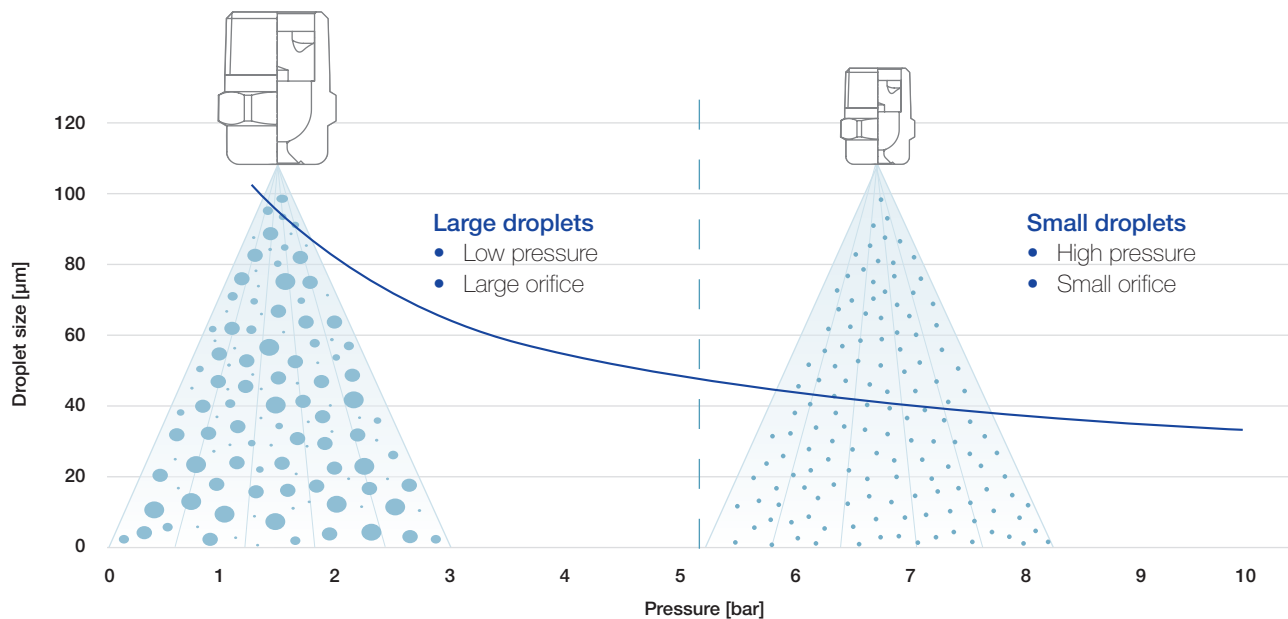

Influences on the droplet size

The following applies in general to all single element nozzles:

- The higher the **operating pressure**, the finer the droplets.
- The smaller the **nozzle outlet bore**, the finer the droplets.
- The higher the **viscosity** of the medium being atomised, the larger the droplets.



Cone and flat fan nozzles are available with varying spray angles. The spray angle can significantly influence the result of the process and should, therefore, be chosen carefully. The angles specified in the tables apply to operation with water at the respective design pressure. In case of deviating operating conditions, the angle may deviate from this value.

Influences on the spray angle

The following factors influence the size of the spray angle:

- **Pressure**

The operating pressure has a significant influence on the spray angle. At very low or very high pressure levels, the spray angle is smaller than at the optimum operating pressure.

- **Distance**

At small distances, the spray width initially increases with the distance and can be determined easily using the trigonometric function. Straight-line pattern can be assumed. With greater spraying heights, the trajectory points increasingly downwards, thus reducing the effective spray angle.

- **Viscosity**

The higher the viscosity of the liquid being sprayed, the smaller the spray angle. The viscosity of liquids can usually be reduced by heating them up.

Change in the spray pressure

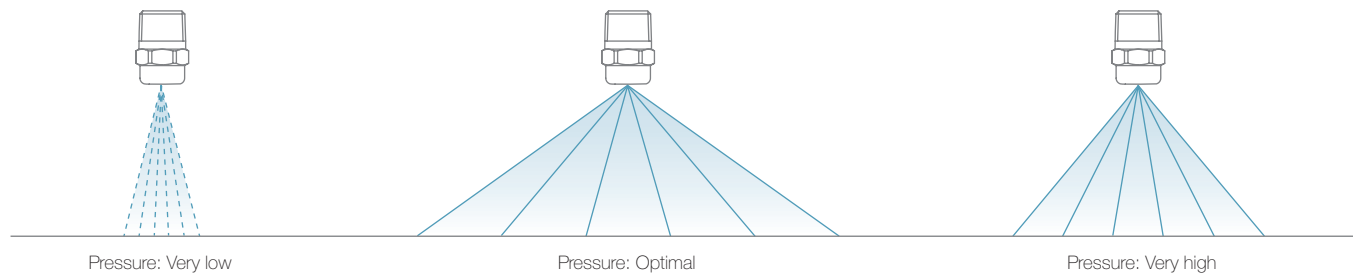

Height of the nozzle position

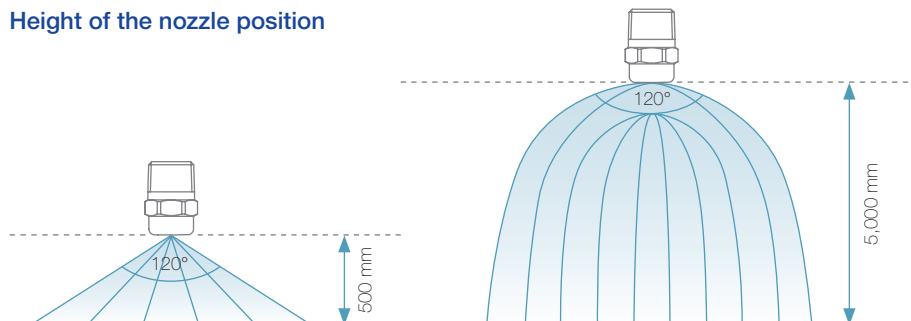



The viscosity of a liquid has a significant influence on the spray behavior of the nozzle. When selecting the right nozzle, the viscosity must, therefore, be taken into account.

Single element nozzle

Example: Hollow cone, full cone, flat fan nozzles

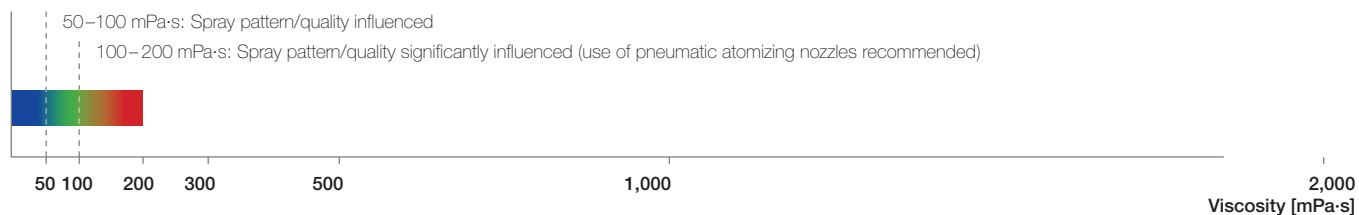

Pneumatic atomizing nozzles (internal mixing)

Example: Series 136.1, 136.2, 136.4, 136.5, 166.1, 166.2, 166.4, 140

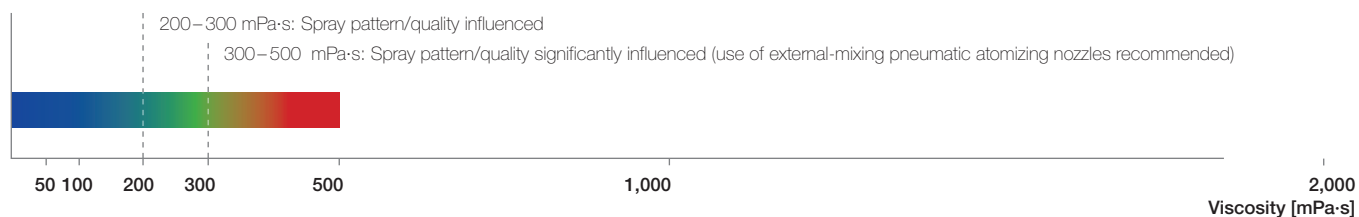

Pneumatic atomizing nozzles (external mixing)

Example: Series 136.13, 136.6, 166.6, 176

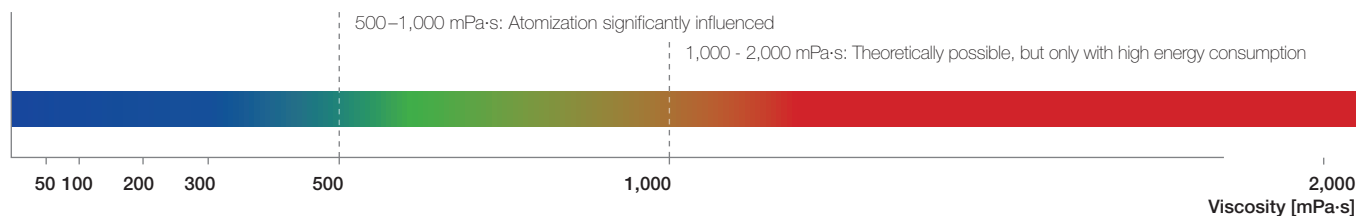

- No influence on the spray pattern
- Influence on the spray pattern
- Significant influence on the spray pattern

Medium	Temperature [°C]	Viscosity [mPa-s]
Water	20	1
Milk	20	2
Olive oil	20	108
Olive oil	60	20
Sugar solution 65° Bx	20	120
Sugar solution 70° Bx	20	400
Gelatine	45	1,200

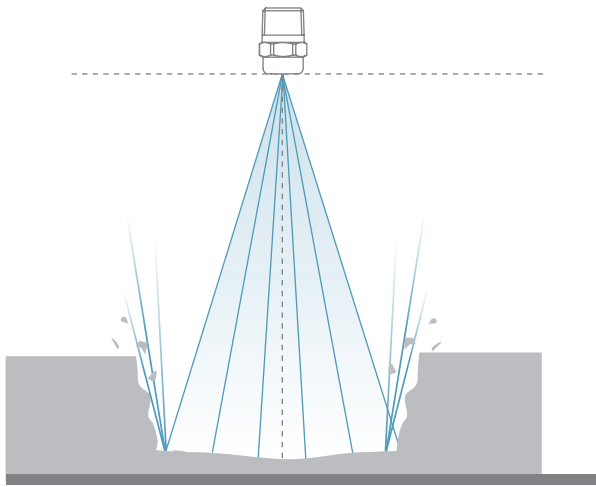

Impact is the pressure in N/mm² that the spray jet generates as it strikes the surface. This is crucial for the majority of cleaning tasks. The greater the impact, the better the cleaning result. Lechler high pressure nozzles are characterized by a uniformly high impact across the entire spray width.

$$I = \frac{\text{Impact force}}{\text{Impact surface}} = \frac{F}{A} \text{ [N/mm}^2\text{]}$$

Influences on the impact

The following factors influence the size of the impact:

- **Impact surface and jet shape**

The impact surface is the area where the spray jet strikes. The smaller the impact surface, the greater the impact. The highest impact values can be achieved with solid stream nozzles and flat fan nozzles with a small spray angle.

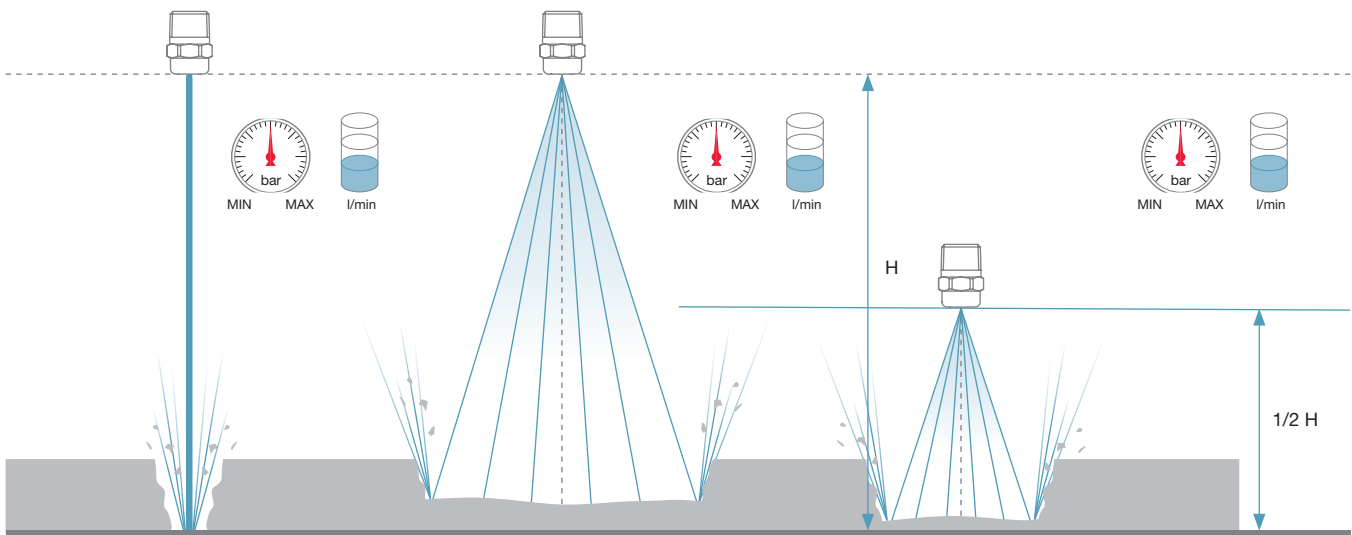

Comparison of the cleaning result of three nozzles at an identical pressure level and flow rate.



- **Pressure**

An increase in the connection pressure leads to an increase in the impact.

- **Flow rate**

An increase in the flow rate by using a larger nozzle leads to a higher impact with otherwise unchanged parameters (spray angle, pressure and medium).

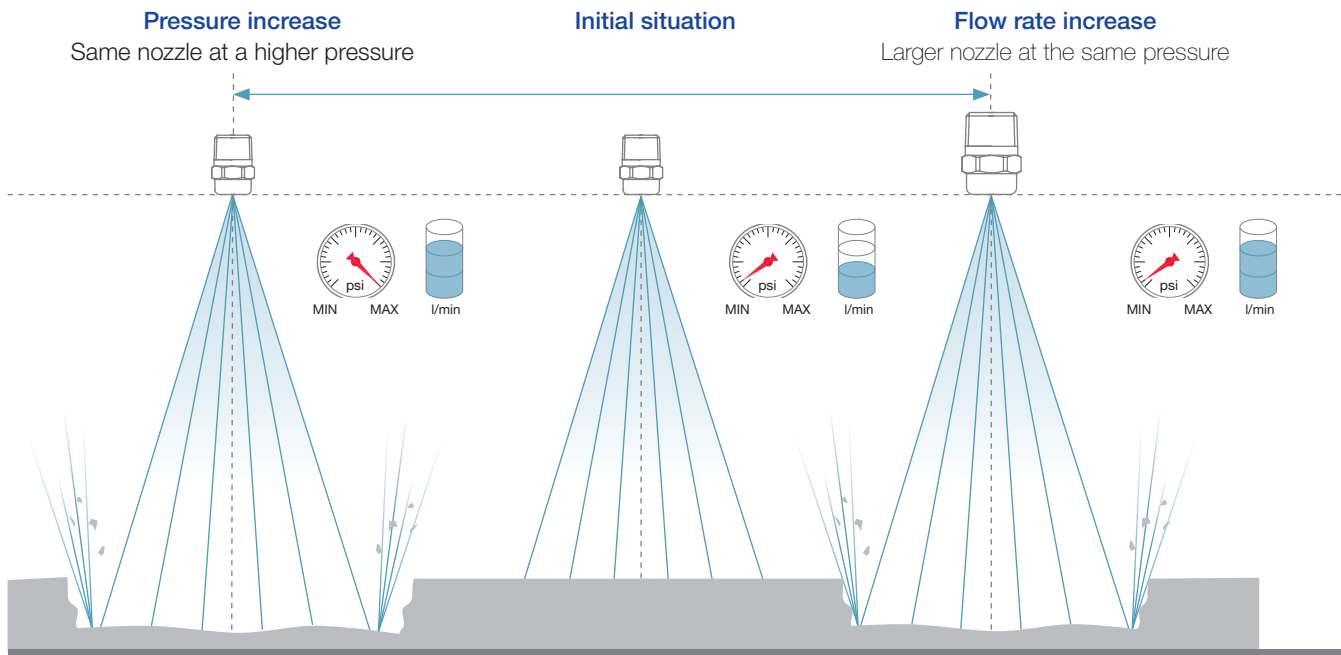

Comparison of the cleaning result of three nozzles with an increase in the pressure level and flow rate.

PLANNING AIDS

NOZZLE ARRANGEMENT



Arrangement of flat fan nozzles with parabolic liquid distribution

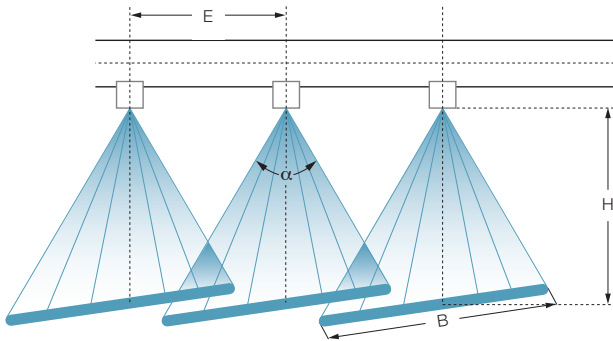

Lechler flat fan nozzles ensure consistent, uniform coverage over the impact surface. For this purpose, the spray widths B should overlap by approx. $1/3$ to $1/4$. To stop the sprays interfering with each other, the nozzles should be aligned at an angle of approx. $5-15^\circ$ to the longitudinal axis of the pipe.

Arrangement of tongue-type nozzles

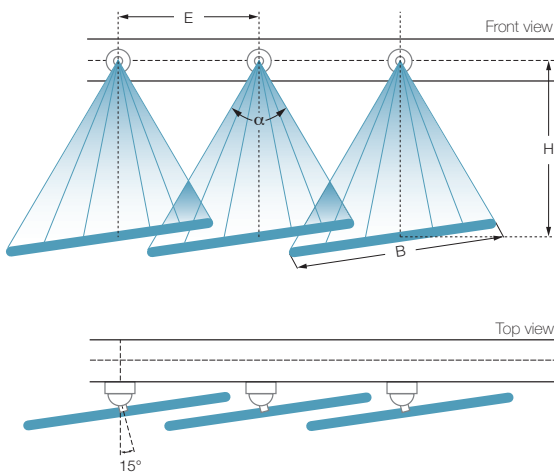

To achieve uniform impact surface coverage, the tongue-type nozzles must be arranged in such a way that the spray widths B overlap by $1/3$ to $1/4$. Therefore, the nozzles should be inclined at an angle of 15° to the vertical of the longitudinal axis of the pipe (either with a nipple welded on at an angle or a Lechler ball joint) to prevent interference of the spray.

Arrangement of full cone nozzles and hollow cone nozzles

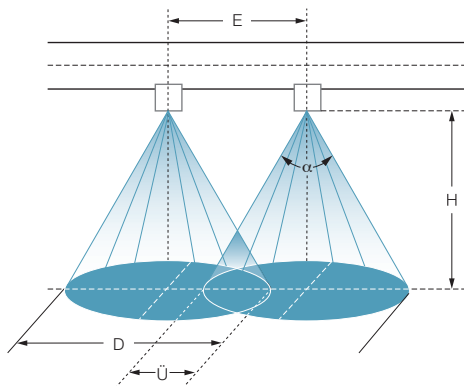

With full cone and hollow cone nozzles, the size of the nozzles distance E must ensure that the circular impact surfaces overlap by approx. $1/3$ to $1/4$.

E = nozzle distance H = nozzle installation height B = spray width α = spray angle \ddot{U} = overlapping of the spray angle D = spray diameter



Square and offset arrangement of full cone nozzles and hollow cone nozzles

Square arrangement

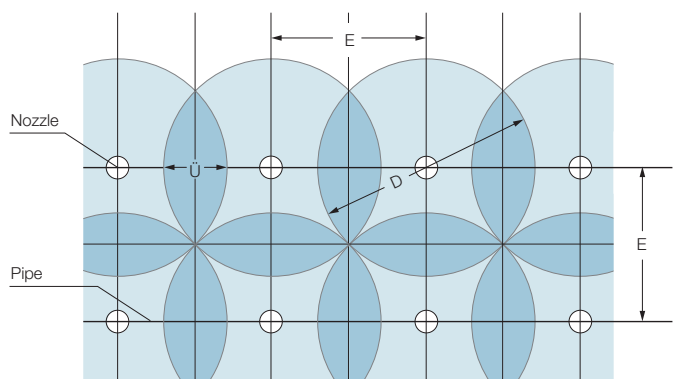

$$\text{Nozzle distance: } E = \frac{D}{\sqrt{2}}$$

$$\text{Overlapping: } \ddot{U} = D - E$$

In addition to these arrangement suggestions, please note the information on the spray angle on page 260 and request a detailed spray width diagram, if required.

Offset arrangement

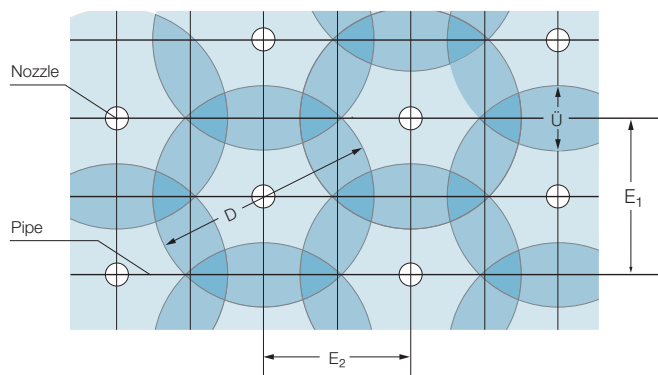

$$\text{Nozzle distance: } E_1 = \frac{D}{2} \cdot \sqrt{3}$$

$$\text{Nozzle distance: } E_2 = \frac{3}{4} \cdot D$$

$$\text{Overlapping: } \ddot{U} = D - E_1$$



PLANNING AIDS

DETERMINATION OF THE PIPE DIAMETER

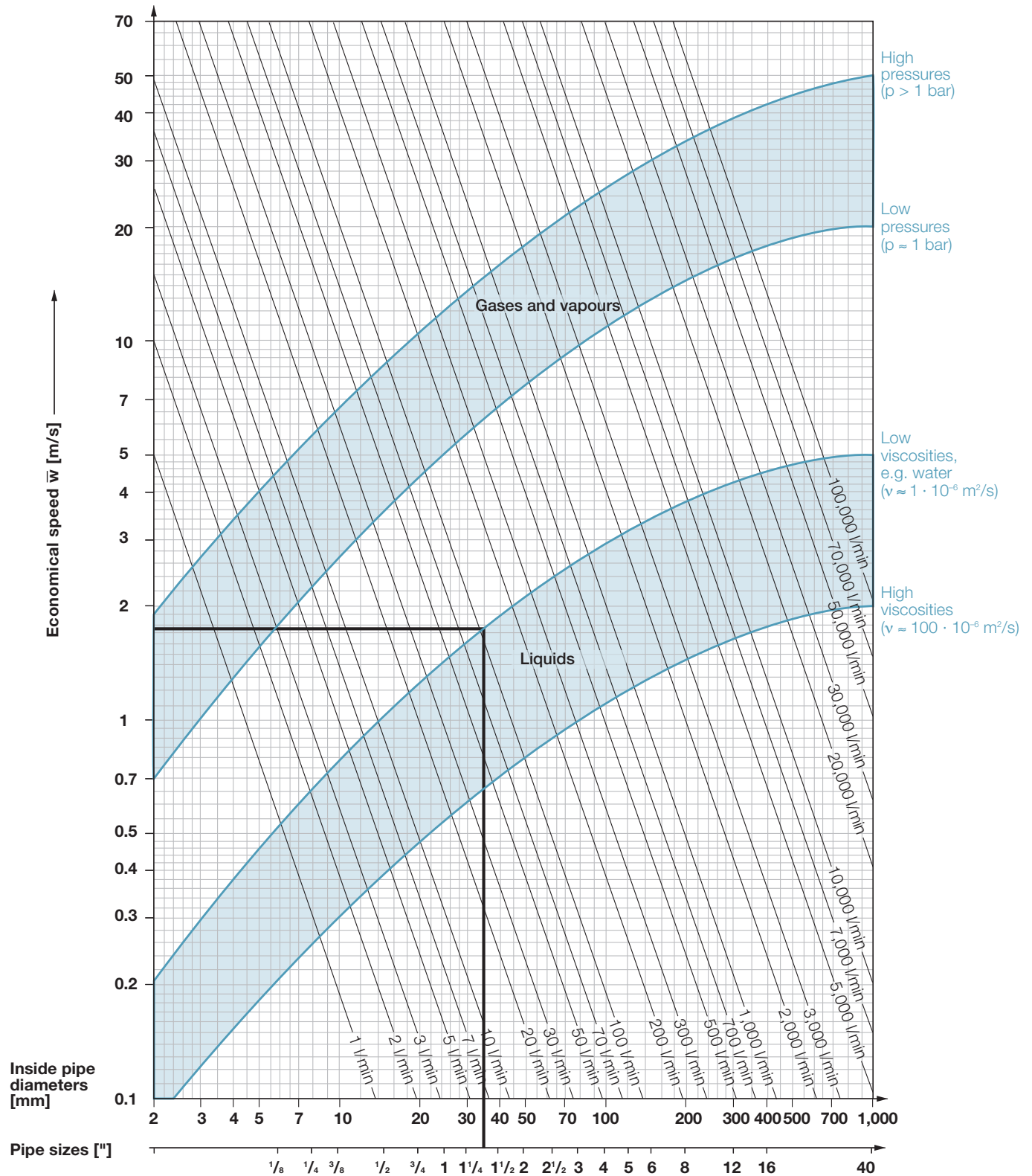

The flow rate data in the diagram refers to gases and steam in operating condition.

Example

You want to atomize 100 liters of water a minute. The viscosity of water is $\nu \approx 1 \cdot 10^{-6} \text{ m}^2/\text{s}$. In the diagram above, look for the intersection of the corresponding viscosity curve and the flow rate lines. Using the coordinates of this point, you can discover the correct inner pipe diameter or pipe size and the most efficient speed.



All the flow rate data in this catalog is based on measurements with water and takes into account the individual flow parameters of the various nozzle designs.

p pressure

Unit	Conversion			
	bar	Pa = N/m ²	psi	lb/sq ft.
1 bar	1	100,000	14.5	2,089
1 Pa	$1 \cdot 10^{-5}$	1	$14.5 \cdot 10^{-6}$	0.0209
1 psi	0.06895	6,895	1	144
1lb/sq ft.	$0.479 \cdot 10^{-3}$	47.9	$6.94 \cdot 10^{-3}$	1

V volume

Unit	Conversion			
	l	m ³	Imp. gal	US gal
1 l (1 dm ³)	1	$1 \cdot 10^{-3}$	0.22	0.264
1 m ³	1,000	1	220	264.2
1 Imp. gal	4,546	$4,546 \cdot 10^{-3}$	1	1,201
1 US gal	3,785	$3,785 \cdot 10^{-3}$	0.8327	1

V̇ flow rate

Unit	Conversion				
	l/s	l/min	m ³ /h	Imp. gal	US gal
1 l/s	1	60	3.6	15.85	13.2
1 l/min	0.0167	1	0.06	0.2642	0.22
1 m ³ /h	0.2778	16.67	1	4.4	3.66
1 Imp. gal/min	0.0631	3.785	0.227	1	0.8327
1 US gal/min	0.076	4.546	0.273	1.201	1

Determination of the external thread diameter

Nominal size of thread ["] for ISO 228 and EN 10226	1/8	1/4	3/8	1/2	3/4	1

ISO 228 threads are cylindrical and usually require a separate flat gasket or R-ring for sealing.
EN 10226 threads are conical and can be sealed with sealing tape, etc.



You can find all the latest information about Lechler, our products and services at any time at www.lechlerusa.com.

3D design data

With the free 3D design data of Lechler nozzles and accessories, we support your design needs at every step.



After registering free of charge, you can download the required data packs in all common CAD formats at <http://lechler.partcommunity.com>.

- Time-saving, direct download of construction drawings and technical data
- Simple product selection similar to the Lechler print catalogue
- Preview function with product photo and 3D graphics
- Available in all common 3D file formats

Always at hand – the Lechler industry app

The Lechler industry app provides all important calculation and conversion programs combined in one interface:

- Unit calculator for pressure, volume and flow rate
- Pressure/Flow rate calculator for single element nozzles, including axial-flow full cone nozzles
- Determination of the pipe diameter



iOS (Apple)



Android (Google)

Available free of charge in the Apple App Store and the Google Play Store.

» PLANNING AIDS CERTIFICATES AND DECLARATIONS



We can issue various certificates and attestations for our products. Whether the desired document can be issued for a specific product must be checked in advance. We will be more than happy to inform you of the conditions for the documents upon request.

Declaration of Compliance EN 10204 - 2.1

This declaration of compliance confirms that the products supplied have been manufactured and tested in accordance with the relevant specifications.

Test Report EN 10204 - 2.2

The test report can be issued either with regard to the material (including the non-specific material certificate of the supplier) or with regard to the spray parameters (spray angle and flow rate, without an additional document).

Inspection Certificate EN 10204 - 3.1

The inspection certificate is usually issued with regard to the material. In this case, the parts are manufactured order-related with re-stamping.

However, a specific certificate can also be issued with regard to the flow rate, spray angle, dimensions of nozzles, etc.

FDA Declaration of Conformity

Confirmation that the material used complies with FDA regulations.

Declaration of Conformity to regulation (EC) no. 1935/2004 and (EC) no. 10/2011

Confirmation that the product supplied is suitable for use with foodstuffs and that the material complies with the stated regulations.

Supplier's Declaration

Certificate issued by Lechler confirming that the products have been wholly produced or originate in the European Union. A supplier's declaration can be issued in relation to a specific order (individual supplier's declaration) or as a long-term supplier's declaration that remains valid for two years.

Certificate of Origin

Official confirmation of the origin of a product, certified by the Chamber of Commerce and Industry.



GREAT ATTENTION
TO DETAIL
**PRECISION BY
LECHLER**



ENGINEERING AND
FABRICATION

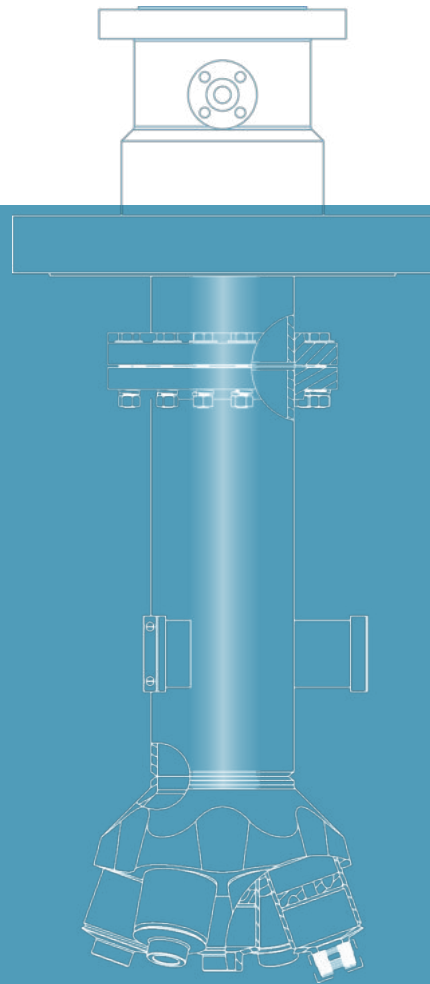

THE HIGHEST STANDARDS IN SPRAY TECHNOLOGY



We keep the highest standards when it comes to designing and engineering spray solutions for our customers. It is important to know what our customers' expectations and requirements are before we even start the design. Lechler uses 4D methodology and in this, our engineers will Define, Design, Develop, and Deliver the optimal spray solution. We work closely with you from start to finish which is one of the many reasons why Lechler is a leader in spray technology.

1. Define

The initial step of our approach begins with evaluating your current process so that our engineers understand your requirements and expectations.



2. Design

All projects are different but our engineers make sure that the necessary software is used along with precise calculations and measurements:

- Proprietary software for layout
- Calculations (flow rates, pressures and nozzle placement, pipe sizing, thermal expansion, and preliminary pump and component selection)
- Computational Fluid Dynamics (CFD) when required
- Finite Element Analysis (FEA), fatigue analysis on high pressure
- Approval drawings
- Detailed drawings

3. Develop

Lechler has testing laboratories, state-of-the-art production facilities, and certifications to develop your ideal solution. There is no need to go outside when we already have all the resources right here.

Production

- Machining (milling, lathing)
- Injection molding (MIM technology)
- Welding & fabrication
- Assembly
- Refurbishment

Testing

- Hydro testing
- Positive material identification
- Nondestructive examination
- Material test reports

Certifications

- ASME - Section IX (Qualified welder performance)
- ASME B & PV Code (Boiler & pressure vessel)
- ASME B31.1 & B31.3 (Power & piping process)
- ANSI & ASTM

4. Deliver

Our ultimate goal is delivering a robust quality solution that meets all of your expectations:

- Quality
- Design
- Price
- Delivery
- And more...



THE INTELLIGENT WAY TO OPTIMALLY USE NOZZLES



When considering flows, turbulence and highly complex spray processes, nobody knows the possibilities better than we do. Just as no one knows your requirements better than you. Together we can find out how to use all your potential.

For simple calculations such as a straight piece of pipe, the flow state is still relatively easy to calculate using paper, pencil, and calculator.



If there is just a slight curve, then this is not so easy. Here, **Computational Fluid Dynamics (CFD)** is required.



Your benefits

- Identifying targeted areas
- Improving nozzle design
- Optimizing in a tight space
- Customer specific process optimization
- Reliable flow conditions
- Precise calculations
- Preventative measures
- And more...

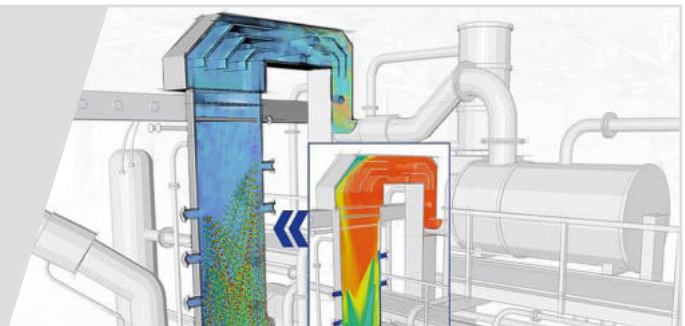

CUSTOM FABRICATION SPRAY SYSTEM SOLUTIONS



Headers, lances, and quills

When it comes to spray system mechanisms, there are hundreds of pieces to consider. From the materials that make the mechanism, to the particular nozzles used to disperse the fluid – there are plenty of opportunities for customization.

While finding the right nozzle for your application is important, it is equally important that the equipment supplying fluid to the nozzle is designed properly to achieve the desired results for a safe and cost-effective installation. Whether your process requires fine atomization, coarse droplets, even coverage, high impact, low impact, or another characteristic, we are happy to guide you with our knowledge in fluid flow simulation, calculations, equipment selection, sizing, and fabrication.

Lechler engineers and welders are highly skilled in the design and fabrication of products such as ASME B31.1 and ASME B31.3. Our facility and welders maintain a comprehensive portfolio of certifications per ASME Code Section IX. Finally, our first class project management, material sourcing, and in-house state-of-the-art PMI equipment, amongst other NDE processes, ensure a successful project with all the required quality measures and documentation.



Lance injector type	Material and test requirements and standards	Connection type and features
Hydraulic	<p>Material selection</p> <ul style="list-style-type: none"> Stainless Steel 316L Hastelloy PP, PVC And many more <p>Code compliance</p> <ul style="list-style-type: none"> ASME B31.1 Power Piping code Metallic industrial piping: DIN EN 13480 Unfired pressure vessels: DIN EN 13445 ASME B31.3 Process Piping code Welder Performance Qualification Records per ASME BPVC section IX Qualification test of welders: DIN EN 287 	<p>Flange connections</p> <ul style="list-style-type: none"> Wedge Standard flange e.g. DIN, ANSI etc. Special flange according to customer specification
Twin-fluid air/liquid	<p>Testing</p> <ul style="list-style-type: none"> ANSI and ASTM testing Non-destructive testing – Penetrant testing: DIN EN ISO 3452 Hardness Hydrostatic pressure test: Pressure Equipment Directive 2014/68/EU, DIN EN 13480-5 and DIN EN 13445-5 Spray and flow testing Phase Doppler Anemometry (PDA) measurement system Magnetic particle inspection: DIN EN ISO 17638 Positive Material Identification 	<p>Additional features</p> <ul style="list-style-type: none"> Shifting device to change the insertion length – with or without gastight sealing Expansion joint or stuffing box for expansion compensation at high temperatures Pre-assembled accessory kits for process media connections (e.g. quick release couplings, shut-off ball valves, strainers) Further special customizations including wear protection, insulation, water cooling or coating Assembly connecting piece with flange connector for welding onto flue gas duct Guide rail to facilitate lance installation
Steam		

PUMP AND CONTROL SKIDS REGULATE WATER FLOW



Our pump and control skids for regulating the flow rates of water and atomizing air are individual customer-specific solutions. Based on the requirements in each case, our first step is to design an overall concept and select the best components in order to create a perfectly tailored solution.

First-class engineering

To perform our engineering, we determine all relevant parameters and define the plant's design. This includes determining the nominal widths and pressure levels as well as designing the pumps and control valves. We draw up the P&I diagram and make detailed equipment and signal lists as an option. Of course, the project is fully documented to ensure that technology and processes can be quickly traced even after years of use.

High-quality components

A precise knowledge of the characteristic properties of our nozzles is essential. For only a complete system that is coordinated to how the nozzles function and operate will ensure smooth and economical operation of the gas cooling system. We fit our pump and control skids with high-quality components from well-known manufacturers as standard and the most important functional components are even realized in redundant design.

Tested quality

The design (e.g. dimensioning of nominal widths) and production are in line with the latest state of the art and comply with all relevant standards. They are equally subject to the Lechler quality management system certified to DIN EN ISO 9001:2015, as is the final acceptance. Before delivery, the pump and control skid undergoes a pressure and tightness test and is checked by our experienced engineers. This will avoid any problems during commissioning.

Control concept

Numerous installations, years of commissioning experience, plus expertise in nozzle technology all contribute to the constant improvement and optimization of Lechler control systems. By installing a control solution from Lechler you will benefit considerably from this wealth of experience. The flexible and fully automatic concept can be perfectly adapted to your process.



Junction Box

All components except the pump motors are wired to a junction box within the pump and control skid unit.

This assures that the customer has a central connection point for all electrical components and measuring devices for further processing in the higher-level control.



Control cabinet with complete PLC

All components including the pumps are wired to a control cabinet. The control cabinet is integrated into the base frame of the pump and control skid unit.

The complete injection control is tested in accordance with valid electrical standards and regulations and allows all relevant process parameters to be visualized over a control panel on the control cabinet.

Specific configuration and extensive testing make commissioning much faster. Communication and the exchange of signals (setpoint, plant status, error messages) with the customer's logic system is carried out via PROFIBUS or PROFINET.

The control has several modes of operation such as automatic mode and manual mode for tests during plant downtimes. In the event of faults, our engineers can quickly perform a remote diagnoses via the installed modem without the need for an on-site visit.

MIST ELIMINATOR SYSTEMS OVERVIEW



Lechler offers a large selection of different separation profiles that can also be combined with each other. This gives us the opportunity to find the optimal solution for your task. We will find the right mist eliminator system for your requirements in terms of efficiency and space.

		<h3>LTH 100</h3>	<ul style="list-style-type: none"> • Horizontal flow • Multi-stage configuration possible • High separation performance • Low pressure loss • Easy to clean 	<ul style="list-style-type: none"> • Variable baffle vane spacing to optimize pressure loss and limit droplets • PPTV, PVDF, PE, stainless steel, and special
		<h3>LTH 500</h3>	<ul style="list-style-type: none"> • Horizontal flow • Reduced installation depths • High separation performance • Available in four variants for optimum adaptation to process requirements 	<ul style="list-style-type: none"> • High hydraulic separation capacity • Variable profile spacing • Angled profile inlet and outlet design • Stainless steel and special
		<h3>LTH 600</h3>	<ul style="list-style-type: none"> • Horizontal flow • Highest separation performance • Low pressure loss • Available in four variants for optimum adaptation to process requirements 	<ul style="list-style-type: none"> • High hydraulic separation capacity • Variable profile spacing • Improved flow routing • Suitable for high flow velocities • PP, stainless steel, and special
		<h3>LTV 271</h3>	<ul style="list-style-type: none"> • Vertical flow • Standardized profile widths • Good separation performance • Low pressure loss 	<ul style="list-style-type: none"> • 23 mm baffle vane spacing • PP, PVDF, and PE
		<h3>LTV 300</h3>	<ul style="list-style-type: none"> • Vertical flow • Highest hydraulic separation capacity • Highest separation performance 	<ul style="list-style-type: none"> • Installation at angles up to 45° • PP, PVDF, PE, stainless steel, and special
		<h3>LTV 400</h3>	<ul style="list-style-type: none"> • Vertical flow • Very good separation performance with minimum pressure loss • Suitable for high dust loads • Reduced support structure 	<ul style="list-style-type: none"> • Variable widths and baffle vane spacing • Easy to clean • PPTV, PVDF, PE, stainless steel, and special

TALK TO US

Customer requirements are different. Sometimes standard solutions do not always make sense. Speak with us today to find the best solution for your purposes.



»» TANK CLEANING NOZZLES

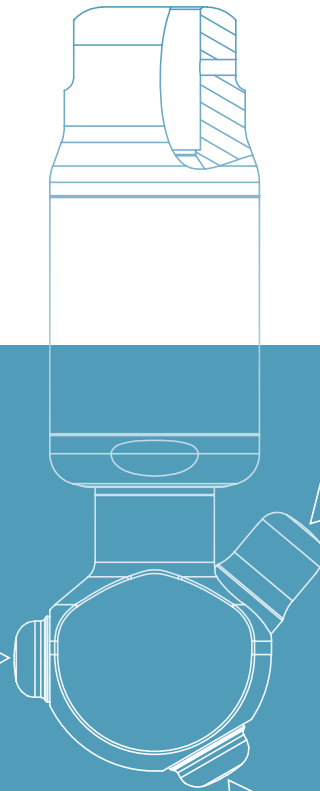

TANK CLEANING NOZZLES

GENERAL INFORMATION



Static

Static spray balls do not rotate and therefore require considerably more liquid for cleaning processes. They are used primarily for rinsing tanks. Spray balls are a very robust and cost effective solution used in many processes.



Free-spinning

Free spinning devices utilize spray orifices that are engineered in a specific position to allow the fluid to drive/rotate the spray head. The repeated impacts of the spray remove the soil and rinse it from the tank surface. This results in optimum cleaning efficiency at low pressures in small to medium-sized tanks.



Controlled rotation

The rotating head is driven by the fluid. A turbine wheel with an internal gear is used to control the rotation. This ensures that the speed remains in the optimum range even at higher pressures. The generated droplets are larger and impact the tank wall at higher speed. These rotating cleaning nozzles achieve higher impact which is especially important for large tanks.



Gear-controlled

The cleaning fluid drives an internal gear by means of a turbine wheel so that the spray head rotates around two axes. The solid jet nozzles mounted on the spray head produce powerful solid stream like jets. These solid jets sweep the entire tank surface in a pre-programmed, model-specific, pattern during a spray cycle. This requires a certain minimum time. These models generate the highest impact and are ideal for very large tanks and the toughest cleaning tasks.

Materials



Lechler tank cleaning nozzles are made of high quality materials such as Stainless steel 316L, PVDF, PEEK or PTFE. In addition to the requirements for material resistance and wear, the materials must also be food grade for use in the beverage, food and pharmaceutical industries.

A large number of the materials used for Lechler tank cleaning nozzles comply with the requirements of the FDA or conform to regulation (EC) 1935/2004.

Hygienic requirements



All Lechler precision nozzles for tank cleaning are designed to meet hygiene requirements. In addition, Lechler also offers special nozzles for particularly stringent hygienic applications, certified to 3-A.

ATEX



Lechler offers several nozzle series designed especially for use in explosive atmospheres.

The respective logo on the product pages indicates which requirements are met.

Good to know

Detailed information can be found in our brochure "Tank and Equipment Cleaning" as well as at <https://www.lechlerusa.com/en/products/product-by-type/tank-and-equipment-cleaning-products>.

Cleaning efficiency classes 1 to 5



Cleaning efficiency classes

Lechler precision nozzles for tank and equipment cleaning are divided into five different cleaning efficiency classes. This is intended to help users find the right nozzle for the respective application quickly.

Every tank cleaning nozzle from Lechler is assigned to a class. The respective class is suitable for specific cleaning tasks.

Dependant upon the application, several cleaning classes can be suitable to the task of removing soils from your application. Generally, it is not possible to quantify and/or differentiate between soil types. The information should be seen as guide intended to make it easier in the selection to finding the right nozzle.

The first step is to find a cleaning efficiency class suitable for the task. If your application is to clean a non-adhering powder material

from a tank surface the cleaning task can be defined as "rinsing". The nozzle series in cleaning efficiency class 1, e.g. static spray ball, or class 2, e.g. MicroWhirly or MiniSpinner, would be suitable for rinsing/washing cycle.

Taking into account the maximum possible tank diameter and the flow rate range, the tables on the following pages can be used to quickly narrow down the suitable nozzles. If the focus is on a low purchase price in the above referenced example, a spray ball should be chosen. If you want to save on your cost-intensive cleaning media, the MicroWhirly or MiniSpinner would be recommended.

If there is no recommended series for the tank diameter, several nozzles can be positioned in the tank to ensure that the distance between nozzle and tank is within the required dimensions.

Simulation software

Various inserts, such as agitators or mixing blades, can cause spray shadowing. To find the ideal nozzle for such complex challenges, we have developed TankClean.

The software simulates the use of various tank cleaning nozzles. The tank shape is freely definable. As a result, subsequent cleaning can be optimized in the planning phase.

TankClean



Function video

www.lechler.com/tankclean

Or scan the QR code.

»» WHAT TO KEEP IN MIND WHEN PLANNING

① The fundamentals of cleaning technology

Sinner's circle

Cost reduction by efficient cleaning processes

② Mechanical cleaning effects with Lechler rotating cleaning nozzles

Mechanical cleaning

① The fundamentals of cleaning technology

Sinner's circle

The Sinner's circle illustrates the interplay between the four main factors for successful cleaning:

- Chemistry (choice of cleaning agent)
- Mechanical (removal of soil via pressure or friction)
- Temperature (at which cleaning is performed)
- Time (duration of the total cleaning processes)

The proportion of the individual factors as a part of the entire cleaning can be varied, provided that the total is 100 per cent. This results in significant savings potentials.

As a result, the intensification of mechanical cleaning enables

the consumption of cleaning agents or the duration of cleaning to be reduced. Consequently, the mechanical factor takes up a greater part of the Sinner's circle, while the other factors can end up being reduced.

Cost reduction by efficient cleaning processes

This is precisely where our nozzles come into play, having been specially developed for delivering a high mechanical cleaning action. Their greater efficiency helps to permanently reduce on going costs for energy and cleaning agents, and also the duration of cleaning. Consequently a one-off investment in improved nozzle technology pays for itself after only a short time.

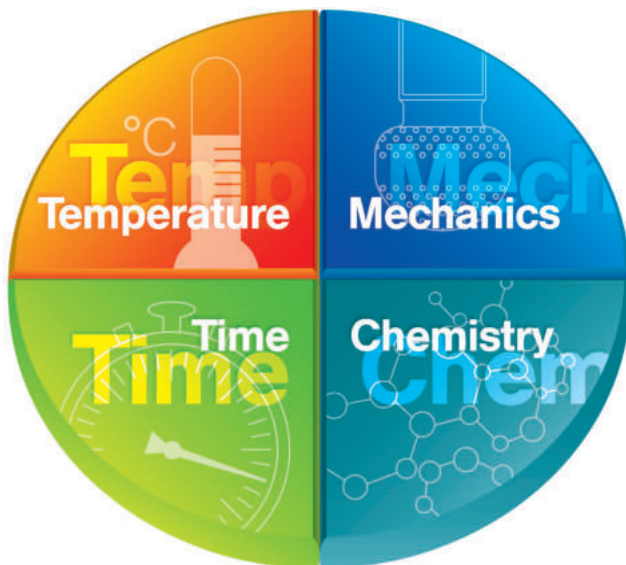

Figure 1: Sinner's circle with equal proportions of the temperature, time, chemistry and mechanical factors.

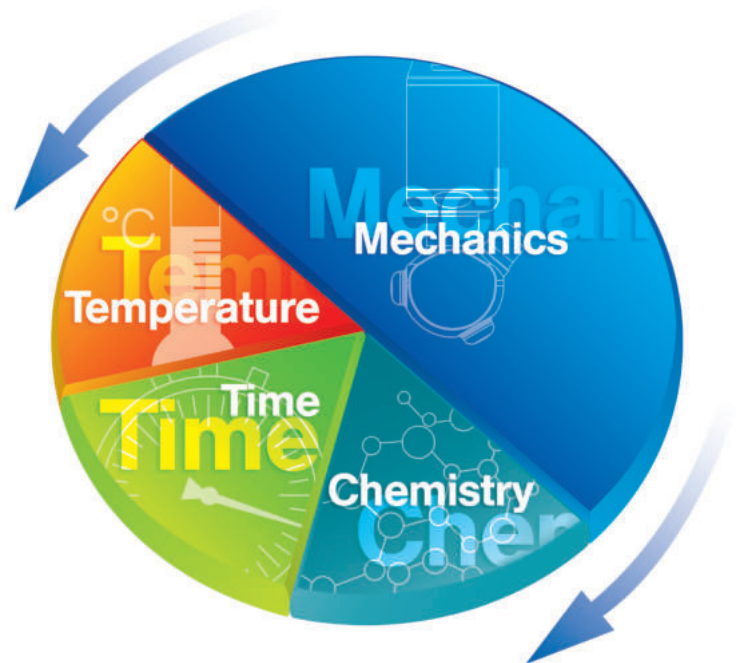

Figure 2: Lechler nozzles and rotating cleaning nozzles have high mechanical cleaning efficiency. This reduces the proportion of the other factors, as well as the resulting costs.

② **Mechanical cleaning effects with Lechler rotating cleaning nozzles**

Mechanical cleaning

Rotating cleaning nozzles deliver the greatest impact when cleaning the surface area of the tank. To achieve this, large droplets must strike at high speed. This enables thick soil to be removed that cannot dissolve in the cleaning fluid. Important influencing factors are the distance between the nozzle and wall, and the operating pressure. If either are too great the fluid

will break down into smaller droplets (see Figs. 3 and 4) and the impact will be reduced.

Besides the impact, the fluid running down the tank wall also has a significant cleaning effect. If the formed film is thick enough, the resulting shear stresses can remove light to moderate soil. In that case, unsprayed patches are less of an issue than is the case during impact cleaning (see Fig. 5).

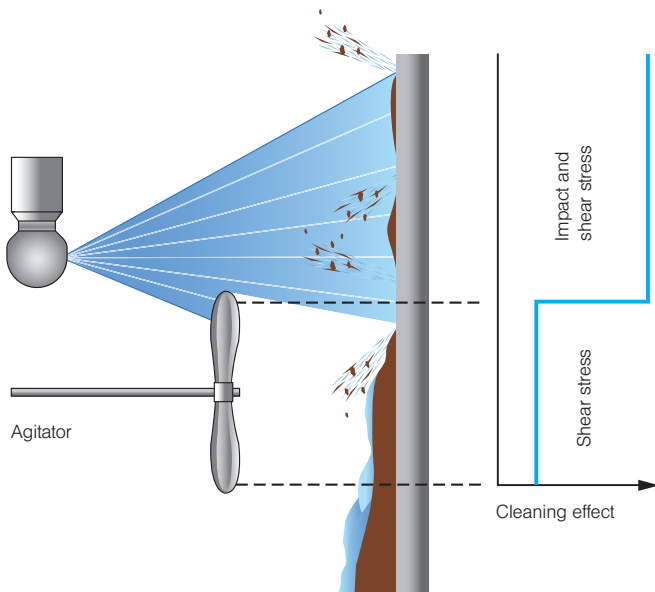

Figure 5: Cleaning mechanisms, impact and shear stress

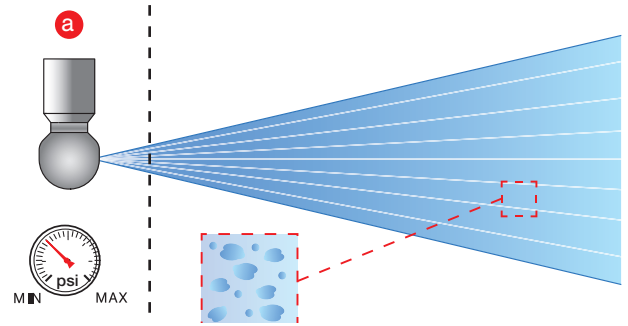

Figure 3: Rotating cleaning nozzles with recommended operating pressure

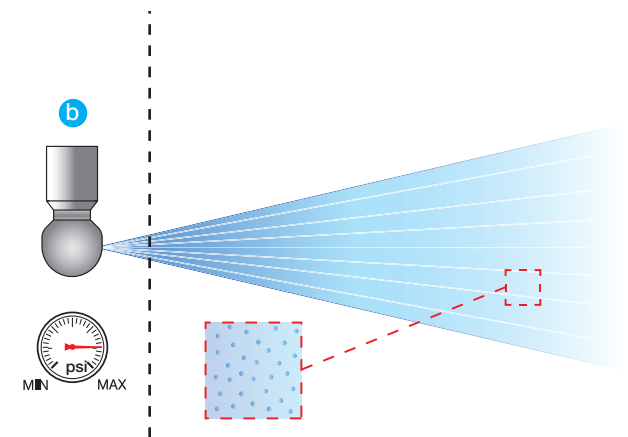

Figure 4: Rotating cleaning nozzles with operating pressure too high

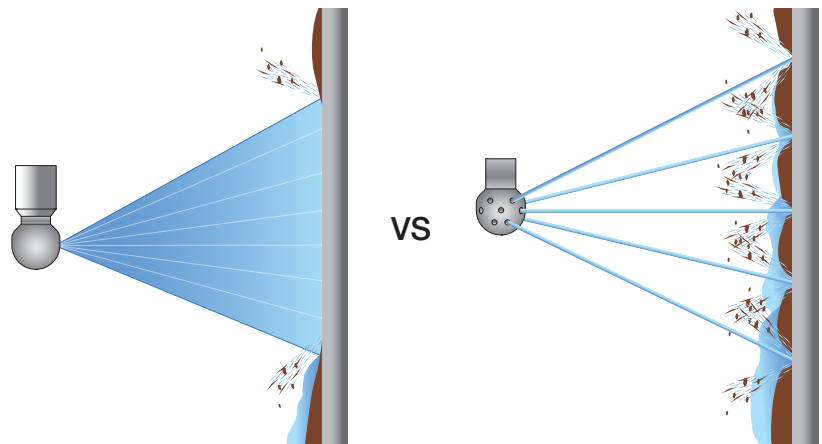
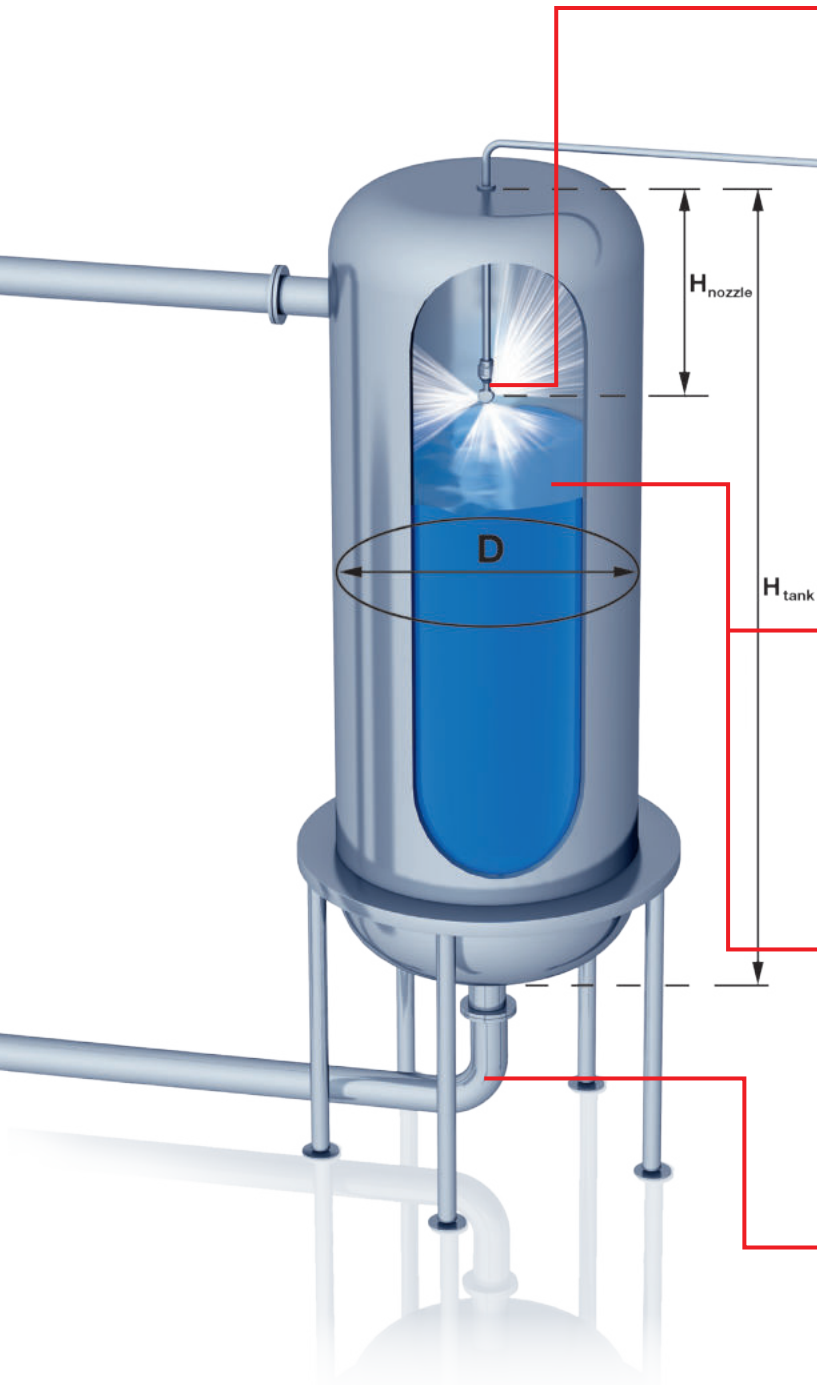

Figure 6: Comparison of rotating cleaning nozzles and static spray balls

»» WHAT TO KEEP IN MIND WHEN PLANNING



Nozzle selection

Choosing the right Lechler rotating cleaning nozzle or static spray ball is determined primarily by the type of soil to be cleaned and the tank diameter. You can find this information on the product pages. It must be guaranteed that the diameter of the tank to be cleaned is smaller than the specified maximum possible tank diameter of the nozzles.

Pump and pipes

The pipe size used depends mainly on the required flow rate and should be chosen so that the pressure losses in the pipe system are as low as possible. It must be guaranteed that the required static operating pressure is available directly at the nozzle. The pump power must be matched to this.

Arrangement

The nozzles must be positioned in the upper part of the tank where possible. The following recommendation applies:

$$H_{\text{nozzle}} = 1/3 \cdot H_{\text{tank}} \text{ and } H_{\text{nozzle}} < 1/3 \cdot D_{\text{max spray diameter nozzle}}$$

In addition, it must be ensured that sufficient cleaning fluid strikes the tank top.

Filling level

If possible, the nozzle should not come into contact with the product during production. The nozzle should be positioned at least 1" above the maximum product level in the tank.

Tank drainage rate

The tank drainage rate is to be selected to prevent the level of liquid from rising during the cleaning process.

Make sure the drain can handle whatever volume you put into the tank. (See chart on the right)

1"	6 gal/min
1 1/2"	13 gal/min
2"	23 gal/min
2 1/2"	35 gal/min
3"	50 gal/min
4"	87 gal/min
5"	141 gal/min
6"	204 gal/min

Number of nozzles



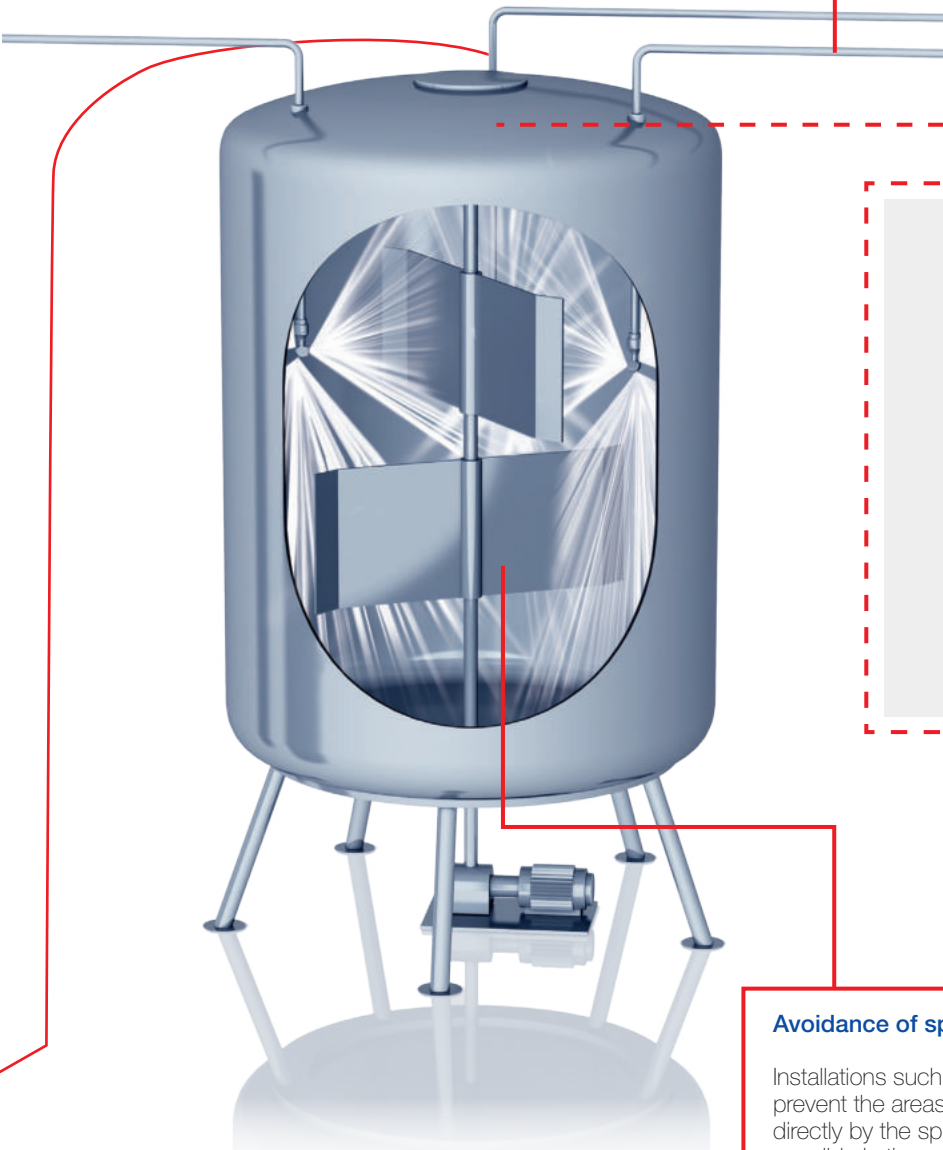



When cleaning large tanks or complex installations, you may need to install several nozzles. The nozzles must be positioned for the spray jets to overlap. These nozzles effectively clean the tank surface area.









Avoidance of spray shadows

Installations such as agitators, baffle plates or pipes prevent the areas behind them from being reached directly by the spray jet. Impact cleaning is not possible in these locations. For this reason, several nozzles must be installed if the tank contains equipment such as agitators or pipes. The number of nozzles should be chosen so that the spray shadows of the individual nozzles are eliminated. In addition, static spray nozzles can also be used for targeted removal of deposits left as a result of spray shadows or in areas that are difficult to clean.

TANK CLEANING NOZZLES OVERVIEW OF SERIES







		Cleaning efficiency class 1					
							
Series		527	540/541	5B2/5B3	500.234	566	500.186
Information on page		65	66	68-68	69	70-71	72
Type		Static spray ball	Static spray ball	Static spray ball	Rotating cleaning nozzle	Rotating cleaning nozzle	Rotating cleaning nozzle
Operating principle	Static	•	•	•			
	Free-spinning				•	•	•
	Controlled rotation						
	Gear-controlled						
Max. tank diameter	Very small (up to ≈ 3.28 ft)	•	•	•	•	•	•
	Small (up to ≈ 6.56 ft)	•	•	•		•	
	Medium (up to ≈ 9.84 ft)	•	•	•			
	Large (up to ≈ 26.25 ft)	•	•	•			
	Very large (> 26.25 ft)	•	•				
Flow rate	Very low (up to ≈ 6.60 gal/min)		•	•	•	•	•
	Low (up to ≈ 13.21 gal/min)	•	•	•			
	Medium (up to ≈ 26.42 gal/min)	•	•	•			
	High (up to ≈ 105.67 gal/min)	•		•			
	Very high (up to ≈ 184.92 gal/min)			•			
Nozzle material	Stainless steel	•	•	•	•	•	
	Plastic						•
Nozzle connection	Thread		•		•	•	•
	Slip-on connection	•		•			
	Tri-Clamp						
ATEX available						•	







Cleaning efficiency class 2

						
500.191	5M1	5M2	5M3	5M4	573/583	5P2/5P3
73	74	76	78	80	82	84
Rotating cleaning nozzle	Rotating cleaning nozzle	Rotating cleaning nozzle	Rotating cleaning nozzle	Rotating cleaning nozzle	Rotating cleaning nozzle	Rotating cleaning nozzle
•	•	•	•	•	•	•
•	•	•	•	•	•	•
		•	•	•	•	•
			•	•	•	
				•		
•	•	•				•
		•	•		•	•
			•	•	•	
				•		
•	•	•	•	•	•	•
		•	•	•	•	
						•
	•	•	•	•		•





		Cleaning efficiency class 3			Cleaning efficiency class 4	
						
Series		594/595	5W9	577	5S6/5S7	5S5
Information on page		86	88	90	91	93
Type		Rotating cleaning nozzle	Rotating cleaning nozzle	Rotating cleaning nozzle	Rotating cleaning nozzle	Rotating cleaning nozzle
Operating principle	Static					
	Free-spinning	•	•	•		
	Controlled rotation				•	•
	Gear-controlled					
Max. tank diameter	Very small (up to ≈ 3.28 ft)	•	•			
	Small (up to ≈ 6.56 ft)	•	•	•	•	•
	Medium (up to ≈ 9.84 ft)	•	•	•	•	•
	Large (up to ≈ 26.25 ft)			•	•	•
	Very large (> 26.25 ft)				•	•
Flow rate	Very low (up to ≈ 6.60 gal/min)	•				
	Low (up to ≈ 13.21 gal/min)	•	•			
	Medium (up to ≈ 26.42 gal/min)	•	•		•	•
	High (up to ≈ 105.67 gal/min)			•	•	•
	Very high (up to ≈ 184.92 gal/min)			•		
Nozzle material	Stainless steel	•	•	•	•	•
	Plastic					
Nozzle connection	Thread	•	•	•	•	•
	Slip-on connection	•	•		•	•
	Tri-Clamp					
ATEX available			•			

Cleaning efficiency class 5			Specialty		Accessories	
						
5T2/5T3	5TB	5TM	597	5P5	Rotation Monitor	HygienicFit
95	97	98	100	101	102	103
High impact cleaner	High impact cleaner	High impact cleaner	Static spray ball	Static spray ball	Accessory	Accessory
			•	•		
•	•	•				
			•	•		
•	•	•				
•	•	•				
•	•	•				
			•	•		
•						
•	•	•				
	•	•				
•	•	•	•	•		
•	•	•	•			•
•	•					

Static spray balls

Series 527



Features:

- Complies with 3-A standards
- Powerful solid jet
- Resistant to high temperatures



Series 527

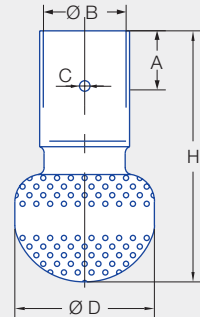

Slip-on connection
ASME - BPE 1997 (OD-Tube)

	Max. tank diameter [ft]	0	5	10	15	20	25	30

Technical data:



Maximum operating temperature
400 °F



Maximum ambient temperature
400 °F



Installation
Operation in every installation position



Bearing
Static – no bearing



Material
Stainless steel
1.44404 (316L)



Weight
.11–1.43lbs



Surface quality
≤ 0.8 µm
OUTSIDE



Surface quality
≤ 0.8 µm
INSIDE



Steam suitability
Suitable



Insertion diameter
1.3- 4in



Recommended filter
Smaller than the narrowest cross-section



Recommended operating pressure
20 psi

Spray angle	Ordering number	Narrowest free cross section Ø [in]	V̇ water [gal/min]				Dimensions approx. (in)					Max. tank diameter [ft]
	Type		p [psi] (p _{max} = 145 psi)				Height H (in.)	Diameter D (in.)	B	C	A	
			20	40	Liters per min. 2 bar	60						
	527.209.1Y.00.75	0.031	13	19	60	23	2.7	1.3	.75	.13	.50	17
	527.209.1Y.01.50	0.043	37	53	170	65	4.6	2.6	1.51	.19	1.00	20
	527.209.1Y.02.00	0.067	92	130	420	160	6.0	4.0	2.01	.19	1.00	27

The maximum tank diameter applies to the recommended operating pressure and is meant as a recommendation only.
The cleaning result is also affected by the type of soiling.

Slip-on information

- R-clip made of stainless steel AISI 316L is included.
- Depending on diameter of the adapter the flow rate can increase due to leakage between the connection and static spray ball.

Static spray balls

Series 540/541



Features:

- Robust and particularly compact design
- Threaded connection
- Suitable for very high temperatures
- Also suitable for operation with steam and air

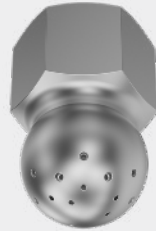

Series 540/541

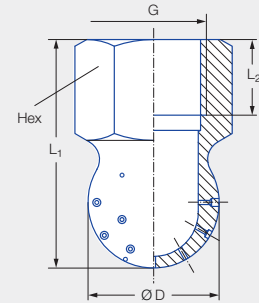

Female thread

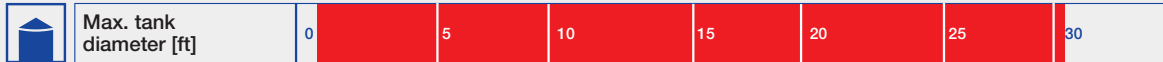

Technical data:



Maximum operating temperature
392 °F



Maximum ambient temperature
482 °F



Installation
Operation in every installation position



Bearing
Static – no bearing



Material
Stainless steel
1.4305 (303)



Weight
.20–.22 lbs



Surface quality
≤ 6.3 µm
OUTSIDE



Surface quality
≤ 6.3 µm
INSIDE



Steam suitability
Suitable



Insertion diameter
1.22 in



Recommended filter
Smaller than the narrowest cross-section



Recommended operating pressure
45 psi

Spray angle	Ordering number		Narrowest free cross section Ø [in]	V̇ water [gal/min]						Max. tank diameter [ft]
	Type	Connection 1/2" Female NPT		p [psi] (p _{max} = 145 psi)						
				7	15	30	45	Liters per min. 3 bar	75	
240° 	540.909.16	BH	0.031	2.33	3.41	4.83	5.81	22	7.63	21
	540.989.16	BH	0.039	3.60	5.27	7.46	9.13	34	11.79	23
	541.109.16	BH	0.059	7.42	10.86	15.35	18.81	70	24.28	25
	541.189.16	BH	0.079	11.66	17.06	24.13	29.55	110	38.15	27
	541.239.16	BH	0.091	15.36	22.49	31.81	38.95	145	50.29	31

BSPP thread available on request.

The maximum tank diameter applies to the recommended operating pressure and is meant as a recommendation only. The cleaning result is also affected by the type of soiling.

Static spray balls RinseClean

Series 5B2/5B3



Features:

- No moving parts
- Self-draining
- Proven use in many applications
- Suitable for very high temperatures and hygienic requirements

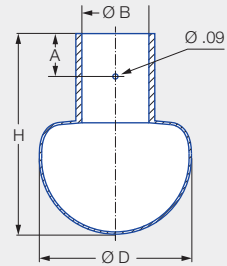
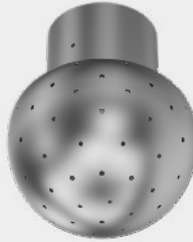

Series 5B2/5B3

Dimension of the slip-on connection according to DIN 10357, Series B

With the slip-on connection, the spray ball is pushed onto the customer's connection pipe and secured with the supplied Pin.



Pin 1

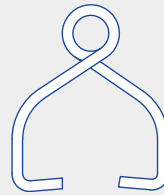

Pin 2-5

	Max. tank diameter [ft]	0	5	10	15	20	25	30	35	40	45
		(This row is highlighted in red in the original image)									

Technical data:



Maximum operating temperature
392 °F



Maximum ambient temperature
482 °F



Installation
Operation in every installation position



Bearing
Static – no bearing



Material
Stainless steel 1.4404 (316L), cotter pin made of stainless steel 1.4404 (316L) or 2.4602 (Alloy 22), cotter pin made of 2.4602 (Alloy 22)



Weight
.02–.66 lbs



Surface quality
Ra ≤ 0.8 µm
polished Ra ≤ 0.5 µm



Surface quality
Ra ≤ 0.8 µm



Steam suitability
Suitable



Insertion diameter
.79–3.54 in



Recommended filter
Smaller than the narrowest cross-section



Recommended operating pressure
30 psi

Function video
www.lechler.com/staticsprayball
Or scan the QR code.





Slip-on connection

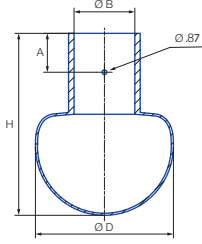

Dimensions slip-on connection according to DIN 10357 Series D (ASME BPE 1997.00 tube compatible)



Pin 1

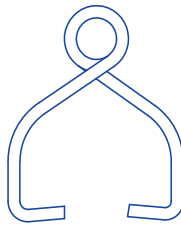

Pin 2-5

Pin	Ordering no.
1	095.013.1Y.06.55
2	095.013.1Y.06.58
3	095.013.1Y.06.56
4	095.013.1Y.06.59
5	095.013.1Y.06.57

With the slip-on connection, the spray ball is pushed onto the customer's connection pipe and secured with the supplied cotter pin.

Spray angle	Ordering number	Type	Narrowest free cross section Ø [in]	V̇ water [gal/min]					Dimensions [in]				Pin	Max. tank diameter [ft]
				p [psi] (p _{max} = 75 psi)					Distance to bore A	Connection B	Height H	Ø D		
				7	15	30	Liters per min. 2 bar	45						
360° 	5B3.089.1Y.A1.00		0.04	6.49	9.50	13.43	50	16.45	0.35	0.48	1.65	1.10	1	7
	5B3.209.1Y.A1.90		0.06	12.98	19.00	26.87	100	32.90	0.35	0.72	1.65	1.10	1	8
	5B3.309.1Y.A2.90		0.07	23.36	34.19	48.36	180	59.32	0.71	0.87	3.31	2.52	2	11
	5B3.379.1Y.A2.60		0.08	33.74	49.39	69.85	260	85.55	0.71	1.11	3.31	2.52	3	17
	5B3.449.1Y.A3.80		0.12	53.21	77.89	110.15	410	134.90	0.71	1.11	3.31	2.52	3	18
	5B3.539.1Y.A5.10		0.13	86.95	127.28	180.00	670	220.45	0.98	2.06	4.37	3.54	5	18

Spray balls with other spray angles and connection options (various slip-on connections as well as threaded and welded connections) can be found in our brochure "Precision nozzles for tank and equipment cleaning".

Information about slip-on connections

- Stainless steel 316L pin supplied.
- Depending on the diameter of the adapter, the flow rate can increase due to a leakage between the adapter and the spray ball.

Threaded connection

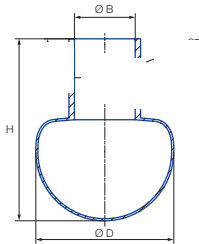

Spray angle	Ordering number	Type	Connection	Narrowest free cross section Ø [in]	V̇ water [gal/min]					Dimensions (in)		Pin	Max. tank diameter [ft]
					p [psi] (p _{max} = 75 psi)					Height H	Ø D		
					7	15	30	Liters per min. 2 bar	45				
360° 	5B2.879.1Y.BB		1/8"	0.03	1.95	2.85	4.03	15	4.94	1.46	0.79	1	6
	5B3.309.1Y.BH		1/2"	0.07	23.36	34.19	48.36	180	59.23	3.31	2.52	2	11
	5B3.379.1Y.BN		1"	0.08	33.74	49.39	69.85	260	85.55	3.31	2.52	3	17
	5B3.539.1Y.BW		2"	0.13	86.95	127.28	180.00	670	220.45	4.37	3.54	5	18

The maximum tank diameter applies to the recommended operating pressure and is meant as a recommendation only. The cleaning result is also affected by the type of soiling.

Rotating cleaning nozzle PicoWhirly Series 500.234



Features:

- Cleaning with rotating solid jet
- Compact design for confined spaces
- Suitable for very high temperatures
- Full stainless steel design

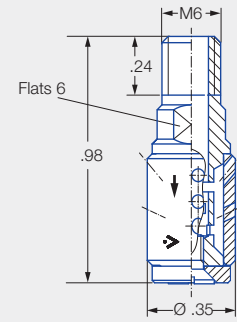

Male thread

Series 500.234

	Max. tank diameter [ft]	0	5	10	15	20	25	30
--	--------------------------------	---	---	----	----	----	----	----

Technical data:



Maximum operating temperature
392 °F



Maximum ambient temperature
392 °F



Installation
Operation in every installation position



Bearing
Kolsterised slide bearing



Material
Stainless steel 1.4404 (316L)



Weight
.03 lbs



Surface quality
Ra ≤ 1.6 µm
OUTSIDE



Surface quality
Ra ≤ 1.6 µm
INSIDE



Steam suitability
Suitable



Insertion diameter
.35 in



Recommended filter
Line strainer with a mesh size of 0.3 mm/50 mesh



Recommended operating pressure
45 psi

Function video

www.lechler.com/picowhirly

Or scan the QR code.



Spray angle	Ordering number		Narrowest free cross section Ø [in]	V̇ water [gal/min]					Max. tank diameter [ft]
	Type	Connection		p [psi] (p _{max} = 75 psi)					
				15	30	45	Liters per min. 3 bar	75	
300° 	500.234.G9	BA	0.07	1.52	2.15	2.63	9.8	3.40	3

The maximum tank diameter applies to the recommended operating pressure and is meant as a recommendation only. The cleaning result is also affected by the type of soiling.

Compressed air should be used for dry blowing for a short time only. Operation above the recommended operating pressure has a negative impact on the cleaning result and wear.

Also available with an M6 metric connection

Rotating cleaning nozzle MicroWhirly Series 566



Features:

- Cleaning with effective flat jets
- Robust slide bearing made of PEEK
- Equipped with a thread or slip-on connection
- Food grade compatibility

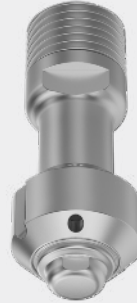

ATEX version available on request

Series 566

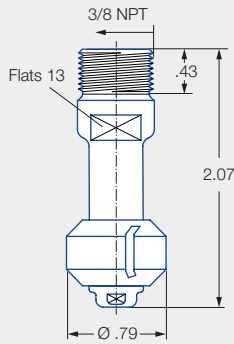

Male thread

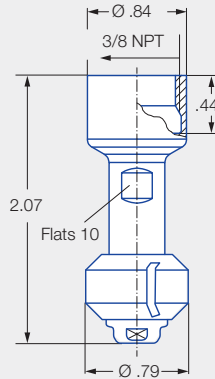

Female thread

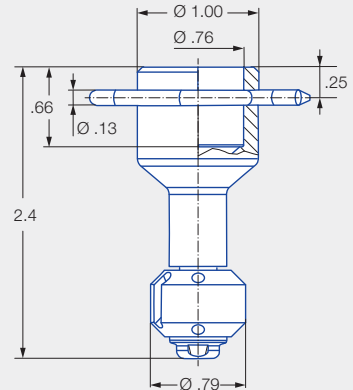

Dimension of the slip-on connection according to ASME-BPE (OD tube)

	Max. tank diameter [ft]	0	5	10	15	20	25	30
--	--------------------------------	---	---	----	----	----	----	----

Technical data:



Maximum operating temperature
302 °F
194 °F (ATEX)



Maximum ambient temperature
392 °F
248 °F (ATEX)



Installation
Operation in every installation position



Bearing
Slide bearing made of PEEK



Material
Stainless steel 1.4404 (316L), PEEK ESD (only ATEX version)



Weight
Threaded = 0.1 lbs
Slip-on = 0.2 lbs



Surface quality
Ra ≤ 1.6 µm
OUTSIDE



Surface quality
Ra ≤ 1.6 µm
INSIDE



Steam suitability
Suitable



Insertion diameter
.79–1.89 in



Recommended filter
Line strainer with a mesh size of 0.3 mm/50 mesh





Recommended operating pressure
30 psi

Function video
www.lechler.com/microwhirly
Or scan the QR code.





Spray angle	Ordering number				Narrowest free cross section \varnothing [in]	\dot{V} water [gal/min]				Max. tank diameter [ft]
	Type	Connection				p [psi] ($p_{max} = 90$ psi)				
		3/8" NPT Male	3/8" NPT Female	3/4"-Slip-on		15	30	Liters per min. 2 bar	45	
180° 	566.873.1Y	BE	BF	TF07	0.04	2.85	4.03	15	4.94	5
	566.933.1Y	BE	BF	TF07	0.09	3.99	5.64	21	6.91	5.5
180° 	566.874.1Y	BE	BF	TF07	0.04	2.85	4.03	15	4.94	5
	566.934.1Y	BE	BF	TF07	0.09	3.99	5.64	21	6.91	5.5
360° 	566.879.1Y	BE	BF	TF07	0.04	2.85	4.03	15	4.94	5
	566.939.1Y	BE	BF	TF07	0.09	3.99	5.64	21	6.91	5.5

BSPP and weld-on version available upon request.

The maximum tank diameter applies to the recommended operating pressure and is meant as a recommendation only. The cleaning result is also affected by the type of soiling.

Compressed air should be used for dry blowing for a short time only. Operation above the recommended operating pressure has a negative impact on the cleaning result and wear.

Information about slip-on connections

- Stainless steel 316L pin supplied.
- Depending on the diameter of the adapter, the flow rate can increase due to a leakage between the adapter and the rotating cleaning nozzle.

Ordering Type + Code = Ordering no.
example: 566.873.1Y + BE = 566.873.1Y.BE

Rotating cleaning nozzle MiniWhirly Series 500.186



Features:

- Economical entry-level model
- Cleaning with effective flat jets
- Specifically designed for barrel and canister cleaning



Series 500,186

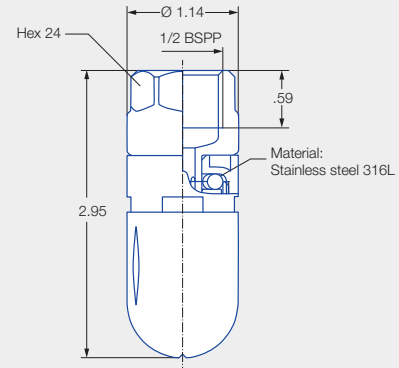

Female thread

	Max. tank diameter [ft]	0	5	10	15	20	25	30
--	-------------------------	---	---	----	----	----	----	----

Technical data:



Maximum operating temperature
122 °F



Maximum ambient temperature
212 °F



Installation
Vertically downwards



Bearing
Ball bearing made of stainless steel 1.4401 (316)



Material
POM, stainless steel 1.4401 (316)



Weight
.15 lbs



Surface quality
Ra ≤ 1.6 µm



Surface quality
Ra ≤ 1.6 µm



Steam suitability
Not suitable



Insertion diameter
1.14 in



Recommended filter
Line strainer with a mesh size of 0.3 mm/50 mesh



Recommended operating pressure
30 psi

Function video
www.lechler.com/miniwhirly
Or scan the QR code.



Spray angle	Ordering number	Narrowest free cross section Ø [in]	V̇ water [gal/min]				Max. tank diameter [ft]
			p [psi] (p _{max} = 75 psi)				
			15	30	Liters per min. 2 bar	45	
300° 	500.186.56.AH	0.07	3.42	4.84	18	5.92	4

The maximum tank diameter applies to the recommended operating pressure and is meant as a recommendation only. The cleaning result is also affected by the type of soiling.

Compressed air should be used for dry blowing for a short time only. Operation above the recommended operating pressure has a negative impact on the cleaning result and wear.

Rotating cleaning nozzle PVDF MicroWhirly Series 500.191



Features:

- Designed for work in a corrosive environment
- Suitable for contact with food and the application of foam
- Very good price-performance ratio
- Made entirely of PVDF

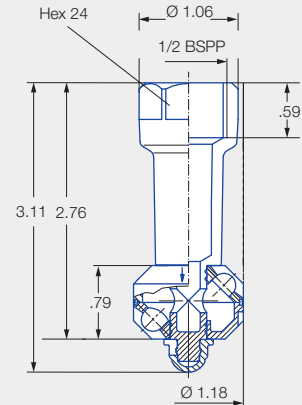

Female thread

Series 500.191

	Max. tank diameter[ft]	0	5	10	15	20	25	30
--	-------------------------------	---	---	----	----	----	----	----

Technical data:



Maximum operating temperature
203 °F



Maximum ambient temperature
302 °F



Installation
Operation in every installation position



Bearing
Slide bearing made of PVDF



Material
PVDF



Weight
.03-.07 lbs



Surface quality
Ra ≤ 1.6 µm



Surface quality
Ra ≤ 1.6 µm



Steam suitability
Not suitable



Insertion diameter
1.18 in



Recommended filter
Line strainer with a mesh size of 0.3 mm/50 mesh



Recommended operating pressure
30 psi

Function video
www.lechler.com/microwhirly
Or scan the QR code.



Spray angle	Ordering number	Narrowest free cross section Ø [in]	V̇ water [gal/min]				Max. tank diameter [ft]
			p [psi] (p _{max} = 75 psi)				
			15	30	Liters per min. 2 bar	45	
180° 	500.191.5E.02	0.09	2.47	3.49	13	4.28	2
180° 	500.191.5E.01	0.09	2.47	3.49	13	4.28	2
270° 	500.191.5E.31	0.09	3.80	5.37	20	6.58	3
360° 	500.191.5E.00	0.09	3.80	5.37	20	6.58	3

The maximum tank diameter applies to the recommended operating pressure and is meant as a recommendation only.

The cleaning result is also affected by the type of soiling.

The PVDF MicroWhirly is not suitable for operation with compressed air or any other gas. Operation above the recommended operating pressure has a negative impact on the cleaning result and wear.

Rotating cleaning nozzle NanoSpinner2 Series 5M1



Features:

- Compact design for confined spaces
- Hygienic design
- Suitable for high temperatures
- Made entirely of stainless steel



**ATEX version
available on request**

Series 5M1

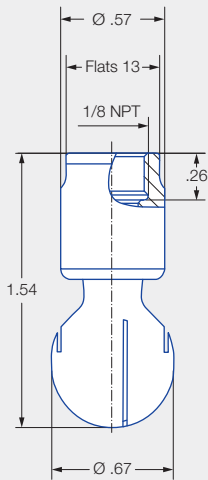

Female thread

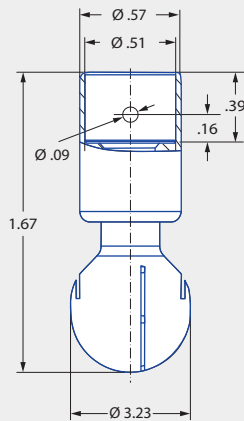

Dimensions of slip-on
connection according to
ASME-BPE (OD tube)

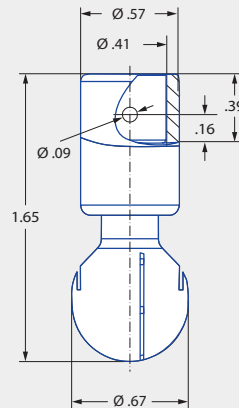

Dimensions of slip-on
connection according to
DIN 11866 series B

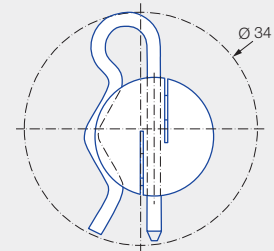

Insertion diameter
of slip-on connection
1.4404 (316L)

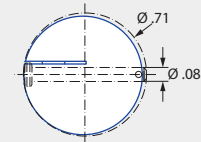

Insertion diameter
of slip-on connection
2.4602 (Alloy 22)

Max. tank diameter [ft]	0	1	2	3	4	5	6	7	8	9

Technical data:



Maximum operating temperature
392 °F
203 °F (ATEX)



Maximum ambient temperature
482 °F
392 °F (ATEX)



Installation
Operation in every installation position



Bearing
Double ball bearing made of stainless steel 1.4404 (316L) or 2.4602 (Alloy 22)



Material
Stainless steel 1.4404 (316L) or 2.4602 (Alloy 22)



Weight
.04 lbs



Surface quality
Ra ≤ 0,4 µm
OUTSIDE



Surface quality
Ra ≤ 0,8 µm
INSIDE



Steam suitability
Not suitable



Insertion diameter
.67-1.34 in



Recommended filter
Line strainer with a mesh size of 0.1 mm/170 mesh



Recommended operating pressure
30 psi

Function video
www.lechler.com/de-en/medialibrary
Or scan the QR Code.





Spray angle	Ordering number				Narrowest free cross section \varnothing [in]	\dot{V} water [gal/min]				Max. tank diameter [ft]
	Type 1/8" Female NPT	Connection				p [psi] ($p_{max} = 100$ psi)				
		1/8 NPT	\varnothing .4 inches in accordance with DIN 11866 Series B	1/2" slip-on connection		15	30	Liters per min. 2 bar	45	
360° 	5M1.879.1Y	BB	TF04	TF05 ¹	0.016	2.85	4.03	15	4.94	4
	5M1.929.1Y	BB	TF04	TF05 ¹	0.020	3.80	5.37	20	6.58	5

¹ The connection variant TF05 is not available as an ATEX variant.

BSPP thread available on request.

The maximum tank diameter applies to the recommended operating pressure and is meant as a recommendation only. The cleaning result is also affected by the type of soiling.

Compressed air should be used for dry blowing for a short time only. Operation above the recommended operating pressure has a negative impact on the cleaning result and wear.

Information on slip-on connection

Cotter pin made of stainless steel 1.4404 (316L) included (Order no. 05M.130.1Y.00.00). For version made of 2.4602 (Alloy 22), bolt with head incl. cotter pin included (Order no. 05M.131.21.00.00).

Depending on the adapter diameter, the flow rate may increase due to the leakage between the adapter and rotating cleaning nozzle.

Rotating cleaning nozzle MicroSpinner 2 Series 5M2



Features:

- Hygienic design
- Suitable for high temperatures
- Made entirely of stainless steel



ATEX version available on request

Series 5M2

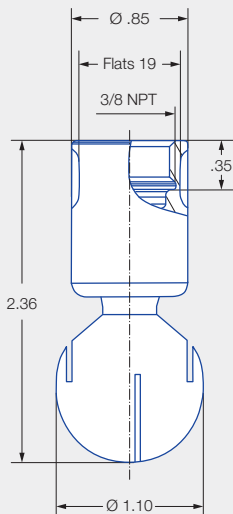

Female thread

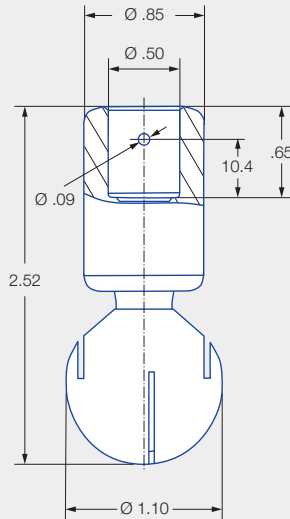

Dimensions of the slip-on connection according to ASME-BE (OD-tube)

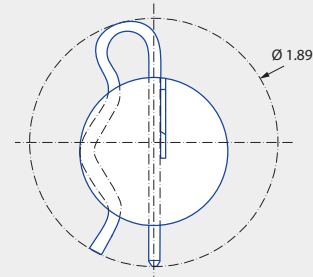

Dimensions of the slip-on connection top view

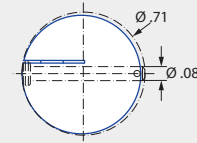

Insertion diameter of slip-on connection 2.4602 (Alloy 22)

	Max. tank diameter [ft]	0	1	2	3	4	5	6	7	8	9

Technical data:



Maximum operating temperature
392 °F
203 °F (ATEX)



Maximum ambient temperature
482 °F
392 °F (ATEX)



Installation
Operation in every installation position



Bearing
Double ball bearing made of stainless steel 1.4404 (316L) or 2.4602 (Alloy 22)



Material
Stainless steel 1.4404 (316L) or 2.4602 (Alloy 22)



Weight
Threaded 0.15 lbs
Slip-on 0.23 lbs



Surface quality
 $Ra \leq 0.4 \mu\text{m}$
OUTSIDE



Surface quality
 $Ra \leq 0.8 \mu\text{m}$
INSIDE



Steam suitability
Conditionally suitable



Insertion diameter
1.10–1.89 in



Recommended filter
Line strainer with a mesh size of 0.1 mm/170 mesh



Recommended operating pressure
30 psi



Adapter
3/8 BSPP is compatible with HygienicFit

Function video
www.lechler.com/de-en/medialibrary
Or scan the QR Code.





Spray angle	Ordering number			Narrowest free cross section \varnothing [in]	\dot{V} water [gal/min]				Max. tank diameter [ft]
	Type	Connection			p [psi] ($p_{max} = 100$ psi)				
		3/8" Female NPT	1/2"-Slip-on		15	30	Liters per min. 2 bar	45	
60° 	5M2.952.1Y	BF	TF05	0.06	4.37	6.18	23	7.57	–
	5M2.042.1Y	BF	TF05	0.12	7.60	10.75	40	13.16	–
180° 	5M2.004.1Y	BF	TF05	0.04	6.08	8.60	32	10.53	6
360° 	5M2.969.1Y	BF	TF05	0.03	4.75	6.72	25	8.23	5
	5M2.049.1Y	BF	TF05	0.04	7.41	10.48	39	12.83	6

BSPP thread, weld-on and further slip-on versions on request.

The max. tank diameter shown above applies for the recommended operating pressure and has to be seen as a recommendation. The cleaning result is also affected by the type of soiling.

Operating with compressed air only for short-term usage. Operation above the recommended operating pressure has negative effects on the cleaning result and wear.

Information slip-on connection

- Pin made of stainless steel 316L included (ordering no. 05M.230.1Y.00.00.0).
- Depending on diameter of the adapter, the flow rate increase due to leakage between connecting pipe and rotating cleaning nozzle.
- Minimum insertion diameter (with mounted pin) is 1.91 in

Example of ordering:	Type	+	Connection	=	Ordering no.
	5M2.952.1Y	+	BF	=	5M2.952.1Y.BF

Rotating cleaning nozzle MiniSpinner 2 Series 5M3



Features:

- Hygienic design
- Suitable for high temperatures
- Made entirely of stainless steel



**ATEX version
available on request**

Series 5M3

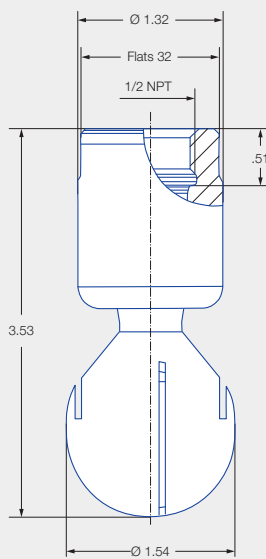

Female thread

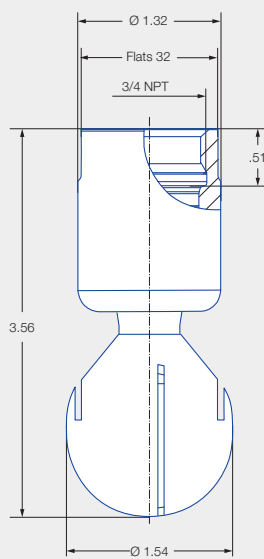

Female thread

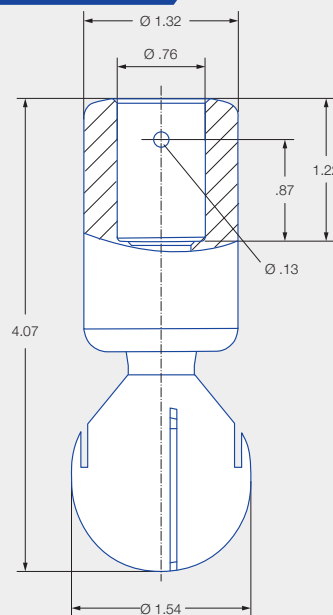

Dimensions of the
slip-on connection according
to ASME-BE (OD-tube)

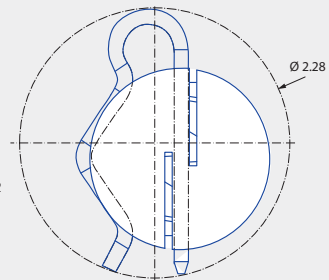

Insertion diameter of
slip-on connection
stainless steel 1.4404 (316L)

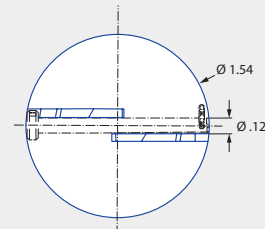

Insertion diameter of
slip-on connection
2.4602 (Alloy 22)

	Max. tank diameter [ft]	0	1	2	3	4	5	6	7	8	9
--	--------------------------------	---	---	---	---	---	---	---	---	---	---

Technical data:



Maximum operating temperature
392 °F
203 °F (ATEX)



Maximum ambient temperature
482 °F
392 °F (ATEX)



Installation
Operation in every
installation position



Bearing
Double ball bearing made of
stainless steel 1.4404
(316L) or 2.4602 (Alloy 22)



Material
Stainless steel 1.4404
(316L) or 2.4602 (Alloy 22)



Weight
Threaded 0.55 lbs
Slip-on 0.75 lbs



Surface quality
Ra ≤ 0.4 µm
OUTSIDE



Surface quality
Ra ≤ 0.8 µm
INSIDE



Steam suitability
Conditionally suitable



Insertion diameter
1.54–2.28 in



Recommended filter
Line strainer with a mesh
size of 0.1 mm/170 mesh



Recommended operating pressure
30 psi







Adapter
1/2 BSPP and 3/4 BSPP
are compatible
with HygienicFit

Function video

www.lechler.com/de-en/medialibrary
Or scan the QR Code.





Spray angle	Ordering number				Narrowest free cross section \varnothing [in]	\dot{V} water [gal/min]				Max. tank diameter [ft]
	Type	Connection				p [psi] ($p_{max} = 100$ psi)				
		1/2" Female NPT	3/4" Female NPT	3/4"- Slip-on		15	30	Liters per min. 2 bar	45	
60° 	5M3.122.1Y	BH		TF07	0.102	11.97	16.93	63	20.73	–
180° 	5M3.133.1Y		BL	TF07	0.047	12.73	18.00	67	22.05	8
180° 	5M3.134.1Y		BL	TF07	0.051	12.73	18.00	67	22.05	8
360° 	5M3.999.1Y		BL	TF07	0.016	5.70	8.06	30	9.87	5
	5M3.089.1Y		BL	TF07	0.028	9.31	13.16	49	16.12	6
	5M3.139.1Y		BL	TF07	0.031	13.11	18.54	69	22.70	7
	5M3.209.1Y		BL	TF07	0.059	19.00	26.87	100	32.90	8

BSPP thread, weld-on and further slip-on versions on request.

The max. tank diameter shown above applies for the recommended operating pressure and has to be seen as a recommendation. The cleaning result is also affected by the type of soiling.

Operating with compressed air only for short-term usage. Operation above the recommended operating pressure has negative effects on the cleaning result and wear.

Information slip-on connection

- Pin made of stainless steel 316L included (Ordering no. 05M.330.1Y.00.00.0).
- Depending on diameter of the adapter, the flow rate increase due to leakage between connecting pipe and rotating cleaning nozzle.
- Minimum insertion diameter (with mounted pin) is 2.32 in.

Example of ordering:	Type	+	Connection	=	Ordering no.
	5M3.122. 1Y	+	BH	=	5M3.122.1Y.BH

Rotating cleaning nozzle MaxiSpinner 2 Series 5M4



Features:

- Hygienic design
- Suitable for high temperatures
- Made entirely of stainless steel



**ATEX version
available on request**

Series 5M4

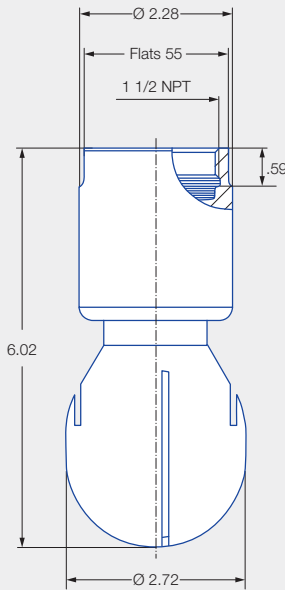

Female thread

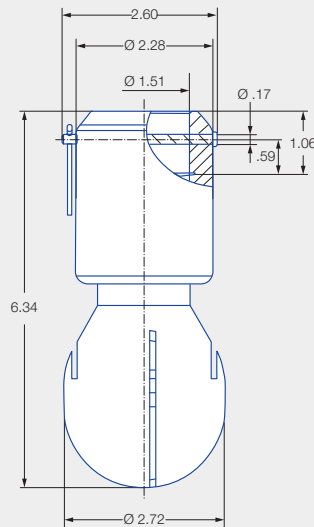

Dimensions of the
1 1/2" slip-on connection according
to ASME-BE (OD-tube)

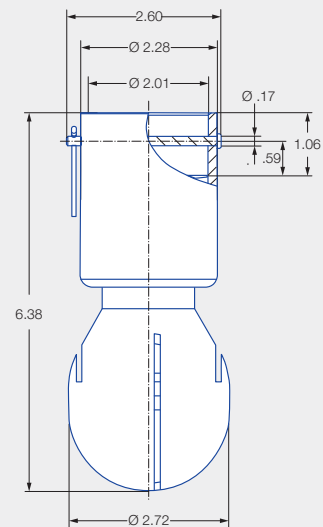

Dimensions of the
2" slip-on connection according
to ASME-BE (OD-tube)

	Max. tank diameter [ft]	0	1	2	3	4	5	6	7	8	9
---	--------------------------------	---	---	---	---	---	---	---	---	---	---

Technical data:



Maximum operating temperature
392 °F
203 °F (ATEX)



Maximum ambient temperature
482 °F
392 °F (ATEX)



Installation
Operation in every
installation position



Bearing
Double ball bearing made of
stainless steel 1.4404
(316L) or 2.4602 (Alloy 22)



Material
Stainless steel 1.4404
(316L) or 2.4602 (Alloy 22)



Weight
1 1/4" threaded 2.43 lbs
1 1/2" threaded 3.75 lbs
1 1/2" slip-on 3.3 lbs
2" slip-on 2.87 lbs



Surface quality
Ra ≤ 0.4 µm
OUTSIDE



Surface quality
Ra ≤ 0.8 µm
INSIDE



Steam suitability
Conditionally suitable



Insertion diameter
2.72 in



Recommended filter
Line strainer with a mesh
size of 0.1 mm/170 mesh



Recommended operating pressure
30 psi



Adapter
1 1/4 BSPP and
1 1/2 BSPP are compatible
with HygienicFit

Function video
[www.lechler.com/de-en/
medialibrary](http://www.lechler.com/de-en/medialibrary)
Or scan the QR Code.





Spray angle	Ordering number					Narrowest free cross section Ø [in]	V̇ water [gal/min]				Max. tank diameter [ft]
	Type	Connection					p [psi] (p _{max} = 100 psi)*				
		1 1/4" Female NPT	1 1/2" Female NPT	1 1/2" Slip-on	2" Slip-on		15	30	Liters per min. 2 bar	45	
360° 	5M4.279.1Y	BQ	BS	TF15	TF20	0.07	28.49	40.30	150	49.35	13
	5M4.329.1Y	BQ	BS	TF15	TF20	0.08	37.99	53.73	200	65.81	15
	5M4.369.1Y	BQ	BS	TF15	TF20	0.09	47.49	67.16	250	82.26	16

BSPP thread and weld-on versions on request.

* Please note the maximum operating pressure of 58 psi for the 2" slip-on connection.

The max. tank diameter shown above applies for the recommended operating pressure and has to be seen as a recommendation. The cleaning result is also affected by the type of soiling

Operating with compressed air only for short-term usage. Operation above the recommended operating pressure has negative effects on the cleaning result and wear.

Information slip-on connection

- Bolt with head incl. pin made of stainless steel 316L included (Ordering no. 05M.431.1Y.00.00.0).
- Depending on diameter of the adapter, the flow rate increase due to leakage between connecting pipe and rotating cleaning nozzle.
- Minimum insertion diameter (with mounted bolt) is the same as for the threaded variants 2.72 in.

Example of ordering:	Type	+	Connection	=	Ordering no.
	5M4.369.1Y	+	BQ	=	5M4.369.1Y.BQ

Rotating cleaning nozzle PTFE Whirly Series 573/583



Features:

- Made entirely of PTFE
- Slip-on connection conforms to 3-A
- Suitable for corrosive environments
- Suitable for very hygienic requirements (e.g. contact with food)



Series 573/583

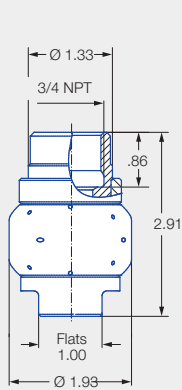

Female thread
3/4 NPT

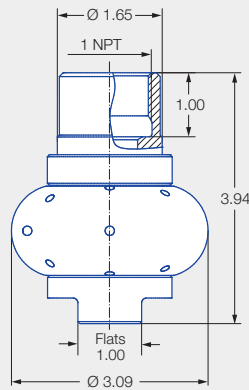

Female thread
1 NPT

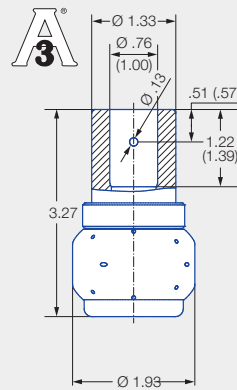

3/4" and 1" slip-on connection
(conforms to 3-A)
Dimension of the slip-on
connection according to
ASME-BPE (OD tube)

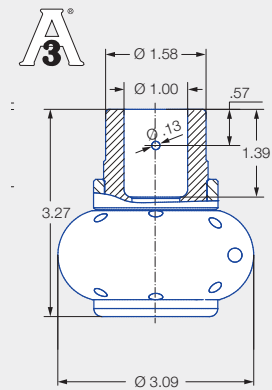

1" slip-on connection
(conforms to 3-A)
Dimension of the slip-on
connection according to
ASME-BPE (OD tube)

Data in brackets refers to
1" version marked with "1".

	Max. tank diameter [ft]	0	5	10	15	20	25	30
--	-------------------------	---	---	----	----	----	----	----

Technical data:



Maximum operating temperature
203 °F



Maximum ambient temperature
392 °F



Installation
Operation in every installation position



Bearing
Slide bearing made of PTFE



Material
PTFE



Weight
3/4" slip-on 0.4 lbs
1" slip-on 1.98 lbs
3/4" slip-on 0.4 lbs
1" slip-on 1.98 lbs



Surface quality
Ra ≤ 0.8 µm
OUTSIDE



Surface quality
Ra ≤ 0.8 µm
INSIDE



Steam suitability
Not suitable



Insertion diameter
1.93–3.09 in



Recommended filter
Line strainer with a mesh size of 0.3 mm/50 mesh



Recommended operating pressure
30 psi

Function video
www.lechler.com/ptfewhirly
Or scan the QR code.





Spray angle	Ordering number					Narrowest free cross section \varnothing [in]	\dot{V} water [gal/min]				Pin	Max. tank diameter [ft]
	Type	Connection					p [psi] ($p_{max} = 85$ psi)					
		3/4" NPT	1" NPT	3/4" Slip-on	1" Slip-on		15	30	Liters per min. 2 bar	45		
	583.114.55	BL		TF07*		.083	12.73	18.00	67	22.05	1	8
	583.264.55	BL		TF07*		.129	27.55	38.95	145	47.71	1	9
	583.344.55		BN			.279	42.74	60.45	225	74.03	2	10
	573.114.55	BL		TF07*		.083	12.73	18.00	67	22.05	1	8
	573.264.55	BL		TF07*		.129	27.55	38.95	145	47.71	1	9
	573.344.55		BN			.232	42.74	60.45	225	74.03	2	10
	583.116.55	BL		TF07*		0.09	12.73	18.00	67	22.05	1	8
	583.266.55	BL		TF07*		.133	27.55	38.95	145	47.71	1	9
	583.346.55		BN		TF10*	.232	42.74	60.45	225	74.03	2	10
	573.116.55	BL		TF07*		0.09	12.73	18.00	67	22.05	1	8
	573.226.55	BL		TF07*		.133	27.55	38.95	145	47.71	1	9
	573.346.55		BN		TF10*	.232	42.74	60.45	225	74.03	2	10
	583.119.55	BL		TF07*	TF10 ^{1*}	0.07	11.02	15.58	58	19.08	1	8
	583.209.55	BL		TF07*	TF10 ^{1*}	0.14	19.00	26.87	100	32.90	1	8
	583.269.55	BL		TF07*		0.19	27.55	38.95	145	47.71	1	9
	583.279.55		BN		TF10*	0.15	28.49	40.30	150	49.35	2	10
	583.349.55		BN		TF10*	0.22	42.74	60.45	225	74.03	2	10

BSPP thread available on request.

¹ See drawing 3 for details (Page 82).

* Complies with and is authorized to use with

The maximum tank diameter applies to the recommended operating pressure and is meant as a recommendation only. The cleaning result is also affected by the type of soiling.

Compressed air should be used for dry blowing for a short time only. Operation above the recommended operating pressure has a negative impact on the cleaning result and wear.

Information about slip-on connections

- Pin made of stainless steel 316L supplied (Ordering no. Pin 1: 095.013.17.06.60, Pin 2: 095.013.17.06.61).
- Depending on the diameter of the adapter, the flow rate can increase due to a leakage between the adapter and the rotating cleaning nozzle.

Ordering	Type	+	Code	=	Ordering no.
example:	583.116.55	+	BL	=	583.116.55.BL

Extendable rotating cleaning nozzle PopUp Whirly Series 5P2/5P3



Features:

- Pressure-dependent automatically extending rotating cleaning nozzle
- Can be installed flush in the tank wall
- Suitable for cleaning pipes and applications that use foam
- Particularly suitable for applications in the pharmaceutical, chemical and food and beverage industry



**ATEX version
available on request**



FDA



Series 5P2

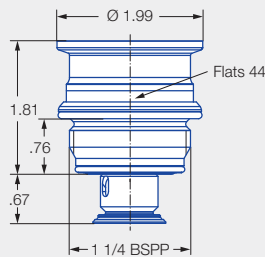

Male thread

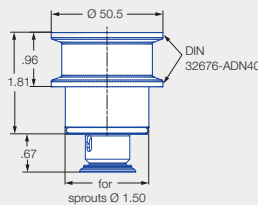

Tri-Clamp connection¹

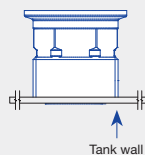
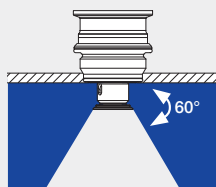

Via thread in idle position



FDA



Series 5P3

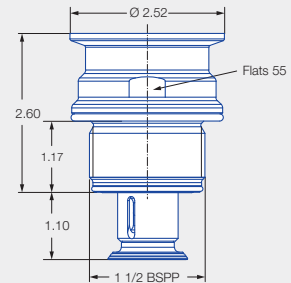

Male thread

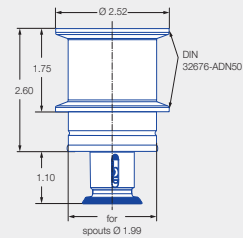

Tri-Clamp connection²

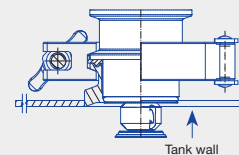
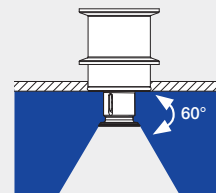

Via Tri-Clamp in operating position

Installation situation

Note Tri-Clamp Version:

Gasket with a thickness of .08 in. must be used with weld-in-flange.

Not sold with nozzle.

5P2 requires standard

DIN32676-A / DN40

5P3 requires standard

DIN32676-A / DN50

¹ A clamp according to DIN 32676-A with a connection diameter of 1.99 in is required to connect the nozzle to the weld-in flange.

² A clamp according to DIN 32676-A with a connection diameter of 2.52 in is required to connect the nozzle to the weld-in flange.





Weld-in Flange for Tri-Clamp

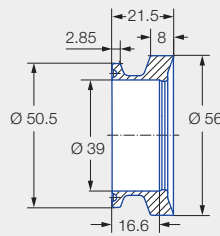

Ordering no.: 050.020.1Y.01.00
Material: Stainless steel 316L

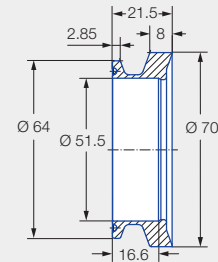

Ordering no.: 050.020.1Y.01.01
Material: Stainless steel 316L

Weld-in socket for Threaded Version

The thread is hygienically sealed with 2 O-rings included in the scope of delivery

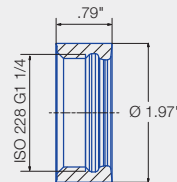

Ordering no.: 050.020.1Y.AQ.00
Material: Stainless steel 316L

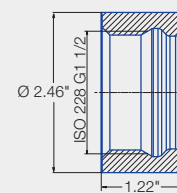

Ordering no.: 050.020.1Y.AS.00
Material: Stainless steel 316L

	Max. tank diameter [ft]	0	5	10	15	20	25	30

Technical data:

<p>Maximum operating temperature 284 °C 284 °C (ATEX)</p>	<p>Maximum ambient temperature 302 °C 284 °C (ATEX)</p>	<p>Installation Operation in every installation position</p>	<p>Bearing Slide bearing</p>
<p>Material Stainless steel 1.4404 (316L), stainless steel 1.4571 (316Ti), stainless steel 1.4401 (316), FKM</p>	<p>Weight 1 1/4" threaded 1.2 lbs 1 1/2" threaded 2.54 lbs 1 1/4" slip-on 2.11 lbs 1 1/2" slip-on 4.52 lbs</p>	<p>Surface quality Ra ≤ 0.8 µm on process side, remaining housing Ra ≤ 1.6 µm</p>	<p>Surface quality Ra ≤ 1.6 µm</p>
<p>Steam suitability Not suitable</p>	<p>Insertion diameter .79–2.52 in</p>	<p>Recommended filter Line strainer with mesh size of 0.3 mm/50 mesh</p>	<p>Recommended operating pressure 30 psi 5P2: Opening pressure approx 14.5 psi and closing pressure approx 7.25 psi 5P3: Opening pressure approx 13.05 psi and closing pressure approx 7.25 psi</p>

Spray angle	Ordering number				Narrowest free cross section Ø [in]	V̇ water [gal/min]				Max. tank diameter [ft]
	Type	Connection				p [psi] (p _{max} = 75 psi)				
		1 1/4" Male BSPP	1 1/2" Male BSPP	Tri-Clamp		15	30	Liters per min. 2 bar	45	
	5P2.873.1Y	AP			0.10	2.85	4.03	15	4.94	2
	5P2.873.1Y			00	0.10	2.85	4.03	15	4.94	2
	5P2.923.1Y	AP			0.14	3.80	5.37	20	6.58	3
	5P2.923.1Y			00	0.14	3.80	5.37	20	6.58	3
	5P3.043.1Y		AR		0.13	7.60	10.75	40	13.16	7
	5P3.043.1Y			00	0.13	7.60	10.75	40	13.16	7

The maximum tank diameter applies to the recommended operating pressure and is meant as a recommendation only. The cleaning result is also affected by the type of soiling.

Information on operation

- The PopUp Whirly is not suitable for operation with compressed air or any other gas.
- Operation above the recommended operating pressure has a negative impact on the cleaning result and wear.

Rotating cleaning nozzle HygienicWhirly Series 594/595



Features:

- Cleaning with highly effective flat jets
- Good cleaning effect even at low pressure
- Suitable for the application of foam



FDA



Series 594/595

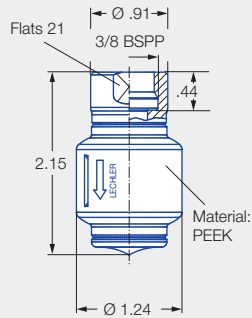

Standard version/Female thread
59x.xx9.1Y.AF

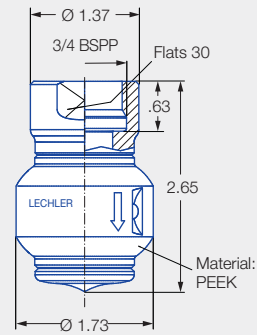

Standard version/Female thread
595.139.1Y.AL

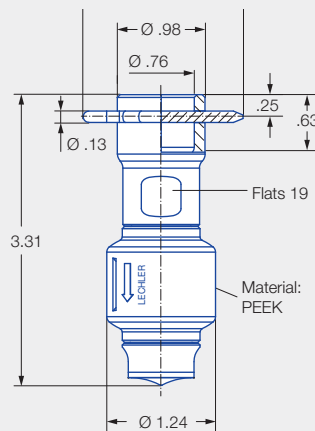

Dimension of the slip-on
connection according to
ASME-BPE (OD tube)
59x.xx9.1Y.67

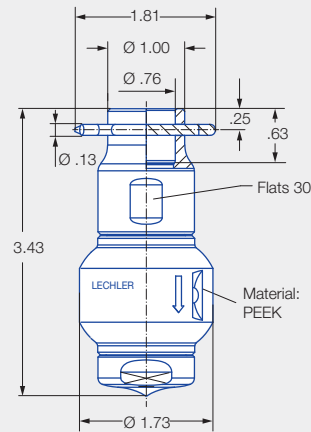

Dimension of the slip-on
connection according to
ASME-BPE (OD tube) 595.139.1Y.67





 Max. tank diameter [ft]	0	5	10	15	20	25
---	---	---	----	----	----	----

Technical data:



Maximum operating temperature
302 °F



Maximum ambient temperature
302 °F



Installation
Operation in every installation position



Bearing
Slide bearing made of PEEK



Material
Stainless steel 1.4404 (316L), PEEK, version with slip-on connection: O-ring made of EPDM



Weight
3/8" 0.21 lbs
3/4" 0.05 lbs



Surface quality
Ra ≤ 0.8 µm
OUTSIDE



Surface quality
Ra ≤ 0.8 µm
INSIDE



Steam suitability
Suitable



Insertion diameter
1.24–1.89 in



Recommended filter
Line strainer with a mesh size of 0.3 mm/50 mesh



Recommended operating pressure
45 psi

www.lechler.com/functionvideo
Or scan the QR code.



Spray angle	Ordering number				Narrowest free cross section Ø [in]	V̇ water [gal/min]						Max. tank diameter [ft]
	Type	Connection				p [psi] (p _{max} = 75 psi)						
		3/8" Female BSPP	3/4" Female BSPP	3/4" slip-on		7	15	30	45	Liters per min. 3 bar	75	
360° 	594.829.1Y	AF		67	0.07	1.48	2.17	3.07	3.76	14	4.86	2
	594.879.1Y	AF		67	0.10	1.91	2.79	3.95	4.84	18	6.24	4
	595.009.1Y	AF		67	0.16	4.13	6.05	8.55	10.48	39	13.53	5
	595.049.1Y	AF		67	0.17	5.19	7.60	10.75	13.16	49	17.00	6
	595.139.1Y		AL		67	2.00	8.69	12.72	17.99	22.03	82	28.44

NPT thread available on request.

The maximum tank diameter applies to the recommended operating pressure and is meant as a recommendation only. The cleaning result is also affected by the type of soiling.

Compressed air should be used for dry blowing for a short time only. Operation above the recommended operating pressure has a negative impact on the cleaning result and wear.

Information about slip-on connections

- Pin made of stainless steel 316L supplied (Ordering no.: 095.022.1Y.50.94.E).
- Depending on the diameter of the adapter, the flow rate can increase due to a leakage between the adapter and the rotating cleaning nozzle.

Ordering	Type	+	Code	=	Ordering no.
example:	594.829.1Y	+	AF	=	594.829.1Y.AF

Rotating cleaning nozzle Whirly 2 Series 5W9



Features:

- Popular and proven design
- Cleaning with effective flat jets
- Various connection options
- Available with a wide range of flow rates and spray angles



**ATEX version
available on request**



FDA

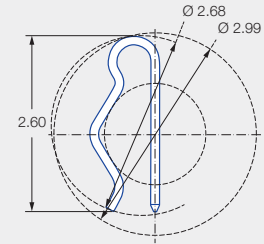

Dimensions slip-on connection
top view

Series 5W9

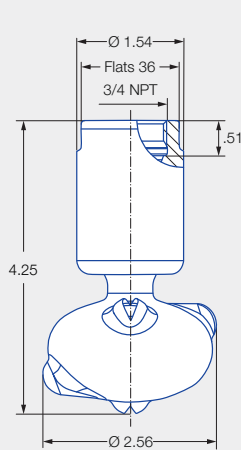

Female thread

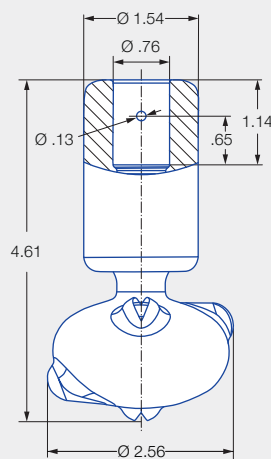

Dimensions slip-on connection
according to ASME-BPE (OD-tube)

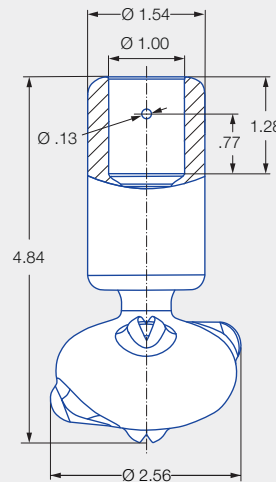

Dimensions slip-on connection
according to ASME-BPE (OD-tube)

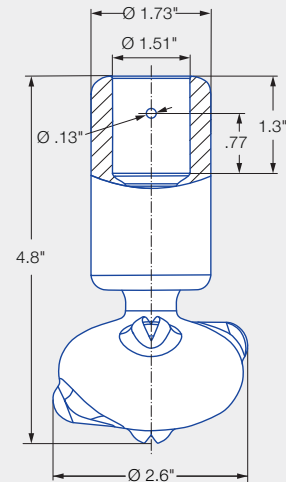

Dimensions slip-on connection
according to ASME-BPE (OD-tube)

	Max. tank diameter [ft]	0	5	10	15	20	25
--	--------------------------------	---	---	----	----	----	----

Technical data:



Maximum operating temperature
302 °F
203 °F (ATEX)



Maximum ambient temperature
392 °F
284 °F (ATEX)



Installation
Operation in every
installation position



Bearing
Double ball bearing
made of stainless steel



Material
Stainless steel 1.4404
(316L), PEEK



Weight
3/4" threaded 0.66 lbs
3/4" slip-on 0.88 lbs
1" slip-on 1.10 lbs
1 1/2" slip-on 2.05 lbs



Surface quality
Ra ≤ 0.4 µm
OUTSIDE



Surface quality
Ra ≤ 0.8 µm
INSIDE



Steam suitability
Not suitable



Insertion diameter
2.74 in



Recommended filter
Line strainer with a mesh
size of 0.1 mm/170 mesh



Recommended operating pressure
30 psi





Adapter
3/4 BSPP is compatible with
HygienicFit

Function video
www.lechler.com/de-en/medialibrary
Or scan the QR Code.





Spray angle	Ordering number					Narrowest free cross section Ø [in]	V̇ water [gal/min]				Max. tank diameter [ft]
	Type	Connection					p [psi] (p _{max} = 87 psi)				
		3/4" Female NPT	3/4" Slip-on	1" Slip-on	1.5" Slip-on		15	30	Liters per min. 2 bar	45	
270° 	5W9.075.1Y	BL	TF07	TF10	TF15	0.08	9.12	12.90	48	15.79	6
	5W9.145.1Y	BL	TF07	TF10	TF15	0.11	13.49	19.07	71	23.36	7
	5W9.195.1Y	BL	TF07	TF10	TF15	0.13	18.43	26.06	97	31.92	8
270° 	5W9.076.1Y	BL	TF07	TF10	TF15	0.08	9.12	12.90	48	15.79	6
	5W9.106.1Y	BL	TF07	TF10	TF15	0.10	11.02	15.58	58	19.08	7
	5W9.196.1Y	BL	TF07	TF10	TF15	0.13	18.43	26.06	97	31.92	8
360° 	5W9.079.1Y	BL	TF07	TF10	TF15	0.06	9.12	12.90	48	15.79	6
	5W9.149.1Y	BL	TF07	TF10	TF15	0.09	13.49	19.07	71	23.36	7
	5W9.199.1Y	BL	TF07	TF10	TF15	0.12	18.43	26.06	97	31.92	8
	5W9.279.1Y	BL	TF07	TF10	TF15	0.14	27.55	38.95	145	47.71	10

BSPP thread available on request.

The maximum tank diameter applies to the recommended operating pressure and is meant as a recommendation only. The cleaning result is also affected by the type of soiling.

Compressed air should be used for dry blowing for a short time only. Operation above the recommended operating pressure has a negative impact on the cleaning result and wear.

Information about slip-on connections

- Pin made of stainless steel 316L supplied (Ordering no.: 095.013.1Y.06.72.0).
- Depending on the diameter of the adapter, the flow rate can increase due to a leakage between the adapter and the rotating cleaning nozzle.
- Minimum insertion diameter (with mounted pin) is 2.68 in.

Ordering	Type	+	Code	=	Ordering no.
example:	5W9.075.1Y	+	BL	=	5W9.075.1Y.BL

Rotating cleaning nozzle Gyro Series 577



Features:

- Cleaning with powerful nozzle inserts
- Suitable for very large tanks
- Available with a wide range of flow rates
- Non clogging and large free cross sections

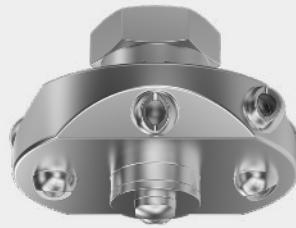

Series 577

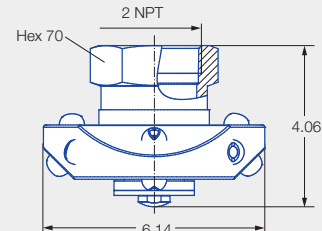
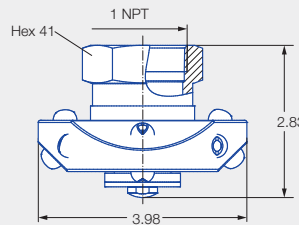

Female thread

Female thread

	Max. tank diameter [ft]	0	5	10	15	20
--	--------------------------------	---	---	----	----	----

Technical data:



Maximum operating temperature
203 °F



Maximum ambient temperature
392 °F



Installation
Vertically downwards



Bearing
Slide bearing made of PTFE



Material
Stainless steel 1.4404 (316L), PTFE



Weight
1" 1.62 lbs
2" 4.19 lbs



Surface quality
Ra ≤ 0.8 µm
OUTSIDE



Surface quality
Ra ≤ 4.0 µm
INSIDE



Steam suitability
Conditionally suitable



Insertion diameter
4.65–6.14 in



Recommended filter
Line strainer with a mesh size of 0.3 mm/50 mesh



Recommended operating pressure
45 psi

Function video
www.lechler.com/gyro
Or scan the QR code.



Spray angle	Ordering number			V̇ water [gal/min]					Max. tank diameter [ft]
	Type	Connection		p [psi] (p _{max} = 75 psi)					
		1" Female NPT	2" Female NPT	15	30	45	Liters per min. 3 bar	75	
360° 	577.289.1Y	BN		31.02	43.87	53.73	200	69.37	11
	577.369.1Y	BN		49.01	69.32	84.89	316	109.60	13
	577.409.1Y		BW	61.11	86.43	105.85	394	136.65	14
	577.439.1Y		BW	73.37	103.75	127.07	473	164.05	15
	577.499.1Y		BW	102.22	144.55	177.04	659	228.56	18

BSPP thread available on request.

The maximum tank diameter applies to the recommended operating pressure and is meant as a recommendation only.

The cleaning result is also affected by the type of soiling.

Compressed air should be used for dry blowing for a short time only. Operation above the recommended operating pressure has a negative impact on the cleaning result and wear.

Contents of Gyro rebuild kit



The PTFE bearings can be replaced easily to extend the life of the unit. A rebuild kit contains: Bearing sleeves and complete instructions.

Size	Product code
1"	057.701.55.01
2"	057.702.55.01

Ordering	Type	+	Code	=	Ordering no.
example:	577.289.1Y	+	BN	=	577.289.1Y.BN



Rotating cleaning nozzle XactClean HP2

Series 5S6/5S7



Features:

- Flat fan nozzle with high impact
- Uniform cleaning
- High efficiency due to controlled rotation
- Suitable for use with steam



ATEX version available on request

Series 5S6/5S7

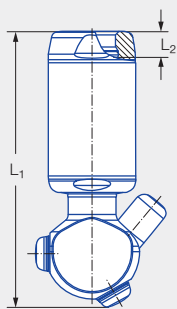

Female thread

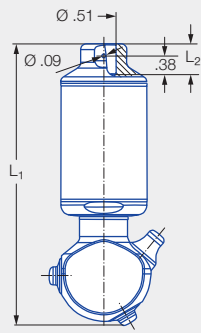

Dimensions of 1/2" slip-on connection according to ASME-BPE (OD tube)

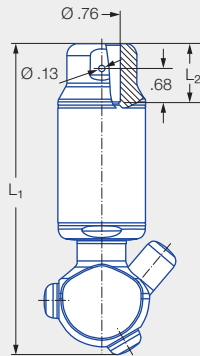

Dimensions of 3/4" slip-on connection according to ASME-BPE (OD tube)

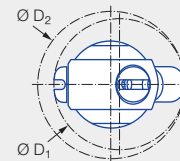

Insertion diameter D_1 and interference circle diameter D_2 of the threaded connection

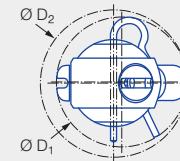

Insertion diameter D_1 and interference circle diameter D_2 of the slip-on connection

Max. tank diameter [ft]	0	5	10	20	25	30
-------------------------	---	---	----	----	----	----

Technical data:



Maximum operating temperature
302 °F



Maximum ambient temperature
302 °F



Installation
Operation in every installation position



Bearing
Double ball bearing



Material
Stainless steel 1.4404 (316L), PEEK, EPDM



Weight
1.43lbs - 1.98lbs



Surface quality Outside
 $R_a \leq 0.8 \mu\text{m}$



Surface quality Inside
 $R_a \leq 1.6 \mu\text{m}$



Steam suitability
Suitable



Insertion diameter
3.19–5.51 in



Recommended filter
Line strainer with a mesh size of 0.3 mm/50 mesh



Recommended operating pressure
45 psi



Adapter
3/8 BSPP, 1/2 BSPP, 3/4 BSPP and 1 BSPP are compatible with HygienicFit



Rotation monitoring
Sensor-compatible, information: see pages 96–97







Maintainable





Connection		Dimensions [in]			
		L ₁	L ₂	Insertion diameter D ₁	Interference circle diameter D ₂
BF	3/8 NPT	5.55	0.35	1.97–2.60	1.97–2.64
BH	1/2 NPT	5.63	0.51	1.97–2.91	1.97–2.99
BL	3/4 NPT	5.63	0.52	1.97–3.11	1.97–3.19
BN	1 NPT	5.51	0.65	2.01–3.11	2.09–3.15
TF05	1/2" slip-on connection	5.91	0.63	2.05–2.60	1.97–2.64
TF07	3/4" slip-on connection	6.30	1.18	2.60–3.11	1.97–3.19

Spray angle	Order number							Narrowest cross-section Ø [in]	V̇ water [gal/min]					Max. tank diameter [ft]
	Type	Connection							p [psi]					
		3/8" Female NPT	1/2" Female NPT	3/4" Female NPT	1" Female NPT	1/2" slip-on	3/4" slip-on		30	45	Liters per min. 3 bar	75	145	
180° 	5S6.963.1Y	BF	BH				TF05	0.07	6.80	8.33	31	10.75	14.95	11
	5S7.043.1Y		BH				TF07	0.08	10.97	13.43	50	17.34	24.11	13
	5S7.113.1Y		BH	BL			TF07	0.08	16.01	19.61	73	25.32	35.20	19
	5S7.183.1Y			BL			TF07	0.08	23.91	29.28	109	37.80	52.56	23
	5S7.223.1Y			BL			TF07	0.08	29.83	36.54	136	47.17	65.59	24
	5S7.253.1Y			BL	BN		TF07	0.08	36.19	44.33	165	57.23	79.57	26
180° 	5S6.964.1Y	BF	BH				TF05	0.07	6.80	8.33	31	10.75	14.95	11
	5S7.044.1Y		BH				TF07	0.08	10.97	13.43	50	17.34	24.11	13
	5S7.114.1Y		BH	BL			TF07	0.08	16.01	19.61	73	25.32	35.20	19
	5S7.184.1Y			BL			TF07	0.08	23.91	29.28	109	37.80	52.56	23
	5S7.224.1Y			BL			TF07	0.08	29.83	36.54	136	47.17	65.59	24
	5S7.254.1Y			BL	BN		TF07	0.08	36.19	44.33	165	57.23	79.57	26
270° 	5S6.965.1Y	BF	BH				TF05	0.07	6.80	8.33	31	10.75	14.95	11
	5S7.045.1Y		BH				TF07	0.08	10.97	13.43	50	17.34	24.11	13
	5S7.115.1Y		BH	BL			TF07	0.08	16.01	19.61	73	25.32	35.20	19
	5S7.185.1Y			BL			TF07	0.08	23.91	29.28	109	37.80	52.56	23
	5S7.225.1Y			BL			TF07	0.08	29.83	36.54	136	47.17	65.59	24
	5S7.255.1Y			BL	BN		TF07	0.08	36.19	44.33	165	57.23	79.57	26
270° 	5S6.966.1Y	BF	BH				TF05	0.07	6.80	8.33	31	10.75	14.95	11
	5S7.046.1Y		BH				TF07	0.08	10.97	13.43	50	17.34	24.11	13
	5S7.116.1Y		BH	BL			TF07	0.08	16.01	19.61	73	25.32	35.20	19
	5S7.186.1Y			BL			TF07	0.08	23.91	29.28	109	37.80	52.56	23
	5S7.226.1Y			BL			TF07	0.08	29.83	36.54	136	47.17	65.59	24
	5S7.256.1Y			BL	BN		TF07	0.08	36.19	44.33	165	57.23	79.57	26
360° 	5S6.969.1Y	BF	BH				TF05	0.06	6.80	8.33	31	10.75	14.95	11
	5S7.049.1Y		BH				TF07	0.08	10.97	13.43	50	17.34	24.11	13
	5S7.119.1Y		BH	BL			TF07	0.08	16.01	19.61	73	25.32	35.20	19
	5S7.189.1Y			BL			TF07	0.08	23.91	29.28	109	37.80	52.56	23
	5S7.229.1Y			BL			TF07	0.08	29.83	36.54	136	47.17	65.59	24
	5S7.259.1Y			BL	BN		TF07	0.08	36.19	44.33	165	57.23	79.57	26

BSPP thread available on request.

The maximum tank diameter applies to the recommended operating pressure and is meant as a recommendation only.

The cleaning result is also affected by the type of soiling.

Compressed air should be used for dry blowing for a short time only. Operation above the recommended operating pressure has a negative impact on the cleaning result and wear.

Information about slip-on connections

- Pin made of stainless steel 316L supplied (Ordering no.: 095.013.1Y.06.45).
- Depending on the diameter of the adapter, the flow rate can increase due to a leakage between the adapter and the rotating cleaning nozzle.

Rotating cleaning nozzle XactClean HP+ Series 5S5



Features:

- High impact and uniform cleaning due to specially developed flat fan nozzles
- Effective cleaning of larger tanks due to higher flow rates
- High dependability and operational reliability due to robust drive unit
- Compatible with Lechler rotation monitoring sensor



FDA



Series 5S5

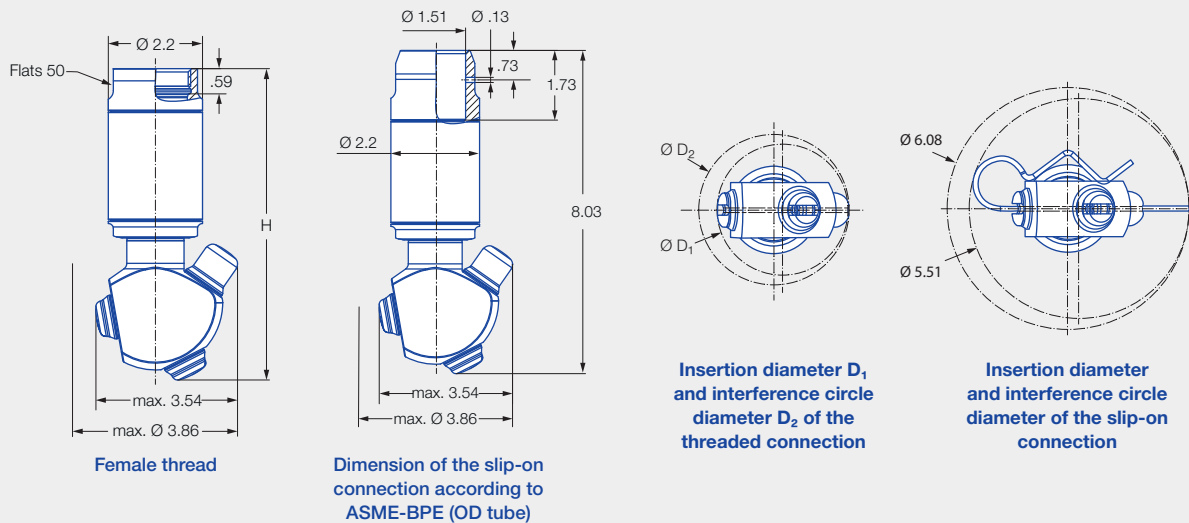

Max. tank diameter [ft]	0	10	20	30
--------------------------------	---	----	----	----

Technical data:



Maximum operating temperature
302 °F



Maximum ambient temperature
302 °F



Installation
Operation in every installation position



Bearing
Double ball bearing



Material
Stainless steel 1.4404 (316L), stainless steel 1.4401 (316), PEEK, EPDM



Weight

1"	4.05 lbs
1 1/4"	3.97 lbs
1 1/2"	3.58 lbs
1 1/2" slip-on	3.97 lbs



Surface quality Outside
 $Ra \leq 0.8 \mu m$



Surface quality Inside
 $Ra \leq 1.6 \mu m$



Steam suitability
Suitable



Insertion diameter
3.19–5.51 in



Recommended filter
Line strainer with a mesh size of 0.3 mm/50 mesh



Recommended operating pressure
45 psi



Adapter
1 BSPP, 1 1/4 BSPP and 1 1/2 BSPP are compatible with HygienicFit



Rotation monitoring
Sensor-compatible, information: see pages 96–97



Maintainable

Function video





www.lechler.com/xactcleanhpplus

Or scan the QR code.





Connection		Dimensions [in]		
		L	Insertion diameter D ₁	Interference circle diameter D ₂
BN	1 NPT	7.28	3.19–3.62	3.23–3.86
BQ	1 1/4 NPT	7.28	3.19–3.62	3.23–3.86
BS	1 1/2 NPT	7.36	3.19–3.62	3.23–3.86

Spray angle	Ordering number					Narrowest free cross section Ø [in]	V̇ water [gal/min]				Max. tank diameter [ft]
	Type	Connection					p [psi] (p _{max} = 145 psi)				
		1" Female NPT	1 1/4" Female NPT	1 1/2" Female NPT	1 1/2"-Slip-on		30	45	liters per min. 3 bar	75	
180° 	5S5.293.1Y	BN			TF15	0.12	44.31	54.27	202	70.06	29
	5S5.323.1Y	BN	BQ		TF15	0.12	53.74	65.82	245	84.97	30
	5S5.363.1Y		BQ	BS	TF15	0.12	67.12	82.21	306	106.13	31
180° 	5S5.294.1Y	BN			TF15	0.12	44.31	54.27	202	70.06	29
	5S5.324.1Y	BN	BQ		TF15	0.12	53.74	65.82	245	84.97	30
	5S5.364.1Y		BQ	BS	TF15	0.12	67.12	82.21	306	106.13	31
270° 	5S5.295.1Y	BN			TF15	0.12	44.31	54.27	202	70.06	29
	5S5.325.1Y	BN	BQ		TF15	0.12	53.74	65.82	245	84.97	30
	5S5.365.1Y		BQ	BS	TF15	0.12	67.12	82.21	306	106.13	31
270° 	5S5.296.1Y	BN			TF15	0.12	44.31	54.27	202	70.06	29
	5S5.326.1Y	BN	BQ		TF15	0.12	53.74	65.82	245	84.97	30
	5S5.366.1Y		BQ	BS	TF15	0.12	67.12	82.21	306	106.13	31
360° 	5S5.299.1Y	BN			TF15	0.12	44.31	54.27	202	70.06	29
	5S5.329.1Y	BN	BQ		TF15	0.12	53.74	65.82	245	84.97	30
	5S5.369.1Y		BQ	BS	TF15	0.12	67.12	82.21	306	106.13	31
	5S5.399.1Y		BQ	BS	TF15	0.12	80.50	98.60	367	127.29	31

BSPP thread available on request.

The maximum tank diameter applies to the recommended operating pressure and is meant as a recommendation only. The cleaning result is also affected by the type of soiling.

Compressed air should be used for dry blowing for a short time only. Operation above the recommended operating pressure has a negative impact on the cleaning result and wear.

Information about slip-on connections

- Pin made of stainless steel 316L supplied (Ordering no.: 095.013.1Y.06.45).
- Depending on the diameter of the adapter, the flow rate can increase due to a leakage between the adapter and the rotating cleaning nozzle.

Ordering Type + Code = Ordering no.
example: 5S5.293.1Y + BN = 5S5.293.1Y.BN

High impact cleaner MeshClean Series 5T2/5T3



Features:

- High degree of effectiveness due to particularly powerful solid stream nozzles
- Suitable for smaller tanks with stubborn dirt
- Active self-cleaning due to engineered nozzle design
- Low maintenance



**ATEX version
available on request**

Series 5T2/5T3

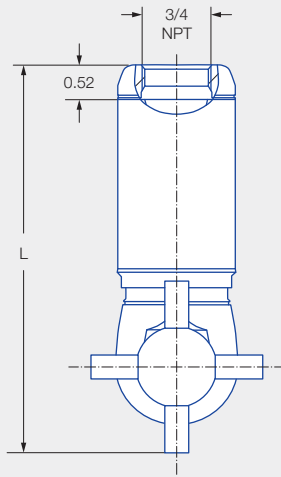

Female thread

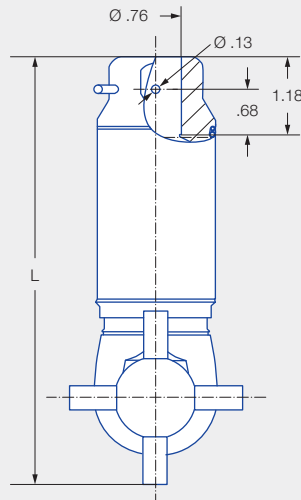

Dimensions of the
slip-on connection according
to ASME-BE (OD-tube)

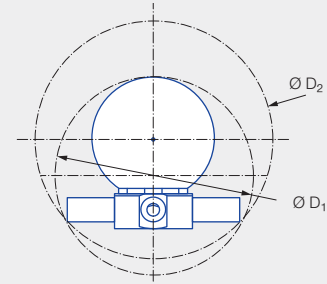

Insertion diameter D_1 and
interference circle diameter D_2
of the threaded connection

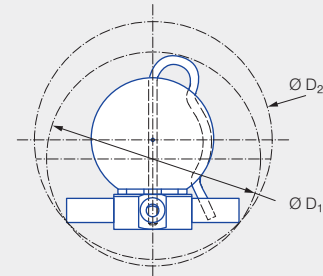

Insertion diameter D_1 and
interference circle diameter D_2
of the slip-on connection





 Max. Tank diameter [ft]	0	15	30	45	60
--	---	----	----	----	----

Technical data:

 Maximum operating temperature 302 °F 302 °F (ATEX)	 Maximum ambient temperature 302 °F 302 °F (ATEX)	 Installation Operation in every installation position	 Bearing Ball bearing
 Material Stainless steel 1.4404 (316L), PTFE, PEEK, EPDM	 Weight 2.2 lbs	 Surface quality Ra ≤ 0.8 µm <small>OUTSIDE</small>	 Surface quality Ra ≤ 1.6 µm <small>INSIDE</small>
 Steam suitability Suitable	 Insertion diameter 2.68–3.23 in	 Recommended filter Line strainer with a mesh size of 0.2 mm/80 mesh	 Recommended operating pressure 75 psi
 Adapter 3/4 BSPP is compatible with HygienicFit	 Rotation monitoring Sensor-compatible, information: see pages 96–97	 Maintainable	Function video www.lechler.com/de-en/medialibrary/videos-general-industry Or scan the QR code.



Spray angle	Ordering number			Narrowest free cross section Ø (in)	Number Ø Nozzles (mm)	V̇ water [gal/min]				Dimensions [in]						Max. tank diameter [ft]
	Type	Connection				p [psi] (p _{max} = 218 psi)				Female thread			Slip-on connection			
		3/4" Female NPT	3/4"-Slip-on			30	75	Liters per min. 5 bar	75 psi [SCFM]	L	Ø D ₁	Ø D ₂	L	Ø D ₁	Ø D ₂	
	5T2.849.1Y	BL	TF07	.067	4 x 1.75	3.40	5.37	20	0.7	5.59	2.68	3.23	6.18	3.03	3.23	37
	5T2.969.1Y	BL	TF07	.106	4 x 2.70	6.80	10.57	40	1.4	5.59	2.68	3.23	6.18	3.03	3.23	39
	5T3.029.1Y	BL	TF07	.126	4 x 3.20	9.35	14.78	55	1.9	5.59	2.68	3.23	6.18	3.03	3.23	41
	5T3.089.1Y	BL	TF07	.157	4 x 4.00	13.42	21.22	79	2.8	5.83	2.91	3.58	6.42	3.23	3.58	42

BSPP connection available on request.

The maximum tank diameter applies to the recommended operating pressure and is meant as a recommendation only. The cleaning result is also affected by the type of soiling.

Information about slip-on connections

- Pin made of stainless steel 316L supplied (Ordering no.: 095.022.1Y.50.60.E).
- Depending on the diameter of the adapter, the flow rate can increase due to a leakage between the adapter and the rotating cleaning nozzle.

High impact cleaner IntenseClean Hygienic Series 5TB



Features:

- Extremely high degree of effectiveness due to particularly powerful solid stream nozzles
- High level of efficiency due to gear-controlled rotation
- Proven in the pharmaceutical and food and beverage industry
- Suitable for pressure levels up to 363 psi
- High surface quality



ATEX version available on request

Series 5TB

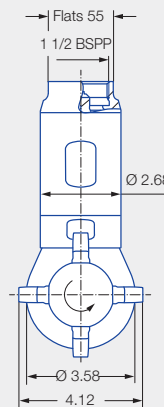
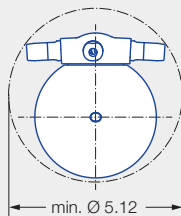

Female thread

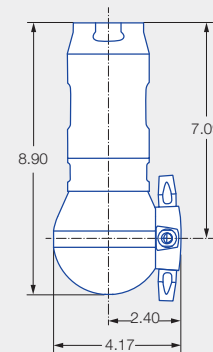

	Max. Tank diameter [ft]	0	15	30	45	60
--	--------------------------------	---	----	----	----	----

Technical data:



Maximum operating temperature
302 °F
207 °F (ATEX)



Maximum ambient temperature
302 °F
275 °F (ATEX)



Installation
Operation in every installation position



Bearing
Ball bearing



Material
Stainless steel 1.4404 (316L), stainless steel 1.4532 (632), PTFE, PEEK, zirconium oxide, EPDM



Weight
8.12 lb



Surface quality
Ra ≤ 0.8 µm
OUTSIDE



Surface quality
Ra ≤ 0.8 µm
INSIDE



Steam suitability
Suitable



Insertion diameter
5.12 in



Recommended filter
Line strainer with a mesh size of 0.2 mm/80 mesh



Recommended operating pressure
75 psi



Rotation monitoring
Sensor-compatible, information: see pages 96–97



Maintainable

Function video

www.lechler.com/intensecleanhygienic5tb
Or scan the QR code.



Spray angle	Ordering number Type 1 1/2" Female NPT	Narrowest free cross section Ø [in]	Number, Ø Nozzles [mm]	V water [gal/min]				Max. tank diameter [ft]
				p [psi] (p _{max} = 363 psi)				
				30	75	Liters per min. 5 bar	145	
	5TB.406.1Y.BS	.24	4 × 6.0	28.72	45.40	169	63.13	46
	5TB.407.1Y.BS	.24	4 × 7.0	35.51	56.15	209	78.07	46
	5TB.408.1Y.BS	.24	4 × 8.0	40.44	63.94	238	88.90	49

BSPP thread available on request.

The maximum tank diameter applies to the recommended operating pressure and is meant as a recommendation only. The cleaning result is also affected by the type of soiling.

High impact cleaner IntenseClean Series 5TM



Features:

- Very robust design
- High degree of effectiveness due to particularly powerful solid stream nozzles
- High level of efficiency due to gear-controlled rotation
- Proven in the petrochemical industry



FDA



ATEX version available on request



Series 5TM

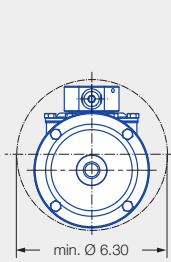

5TM.2xx.1Y
(2 nozzles)

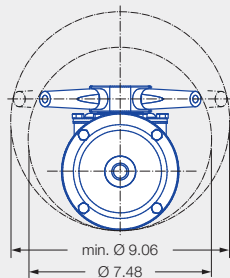

5TM.4xx.1Y
(4 nozzles)

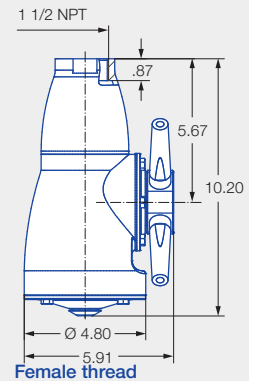
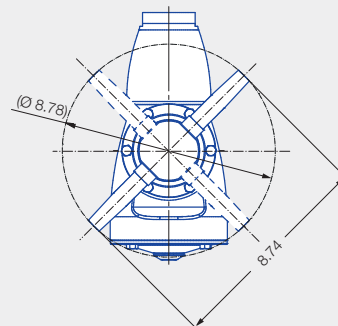

	Max. tank diameter [ft]	0	20	40	60	80
--	--------------------------------	---	----	----	----	----

Technical data:



Maximum operating temperature
203 °F
203 °F (ATEX)



Maximum ambient temperature
284 °F
248 °F (ATEX)



Installation
Operation in every installation position



Bearing
Ball bearing



Material
Stainless steel 1.4404 (316L), stainless steel 1.4301 (304), stainless steel 1.4310 (302), PTFE, PEEK



Weight
16.5 lbs



Surface quality
Ra ≤ 0.8 µm
OUTSIDE



Surface quality
Ra ≤ 4.5 µm
INSIDE



Steam suitability
Not suitable



Insertion diameter
6.30–9.06 in



Recommended filter
Line strainer with a mesh size of 0.2 mm/80 mesh



Recommended operating pressure
75 psi



Rotation monitoring
Sensor-compatible, information: see pages 96–97



Maintainable

Function video
www.lechler.com/intenseclean
Or scan the QR code.





Spray angle	Ordering number				Narrowest free cross section Ø [in]	Number, Ø Nozzles [mm]	V̇ water [gal/min]					Max. tank diameter [ft]
	Type	Connection					p [psi] (p _{max} = 100 psi)					
		1 1/2" Male NPT	1 1/2" Female NPT	1 1/2" CL 150 Flange			40	60	75	Liters per min.		
										5 bar	100	
360° 	5TM.208.1Y	BR	BS	015	0.31	2 x 8.0	39	48	53	198	61	79
	5TM.209.1Y	BR	BS	015	0.35	2 x 9.0	45	55	61	227	70	79
	5TM.210.1Y	BR	BS	015	0.39	2 x 10.0	50	61	68	253	79	79
	5TM.211.1Y	BR	BS	015	0.43	2 x 11.0	58	71	79	295	92	75
	5TM.406.1Y	BR	BS	015	0.24	4 x 6.0	43	53	59	224	69	59
	5TM.407.1Y	BR	BS	015	0.28	4 x 7.0	53	65	72	269	83	66
	5TM.408.1Y	BR	BS	015	0.31	4 x 8.0	62	76	85	316	98	72
	5TM.409.1Y	BR	BS	015	0.35	4 x 9.0	73	89	99	370	115	75
5TM.410.1Y	BR	BS	015	0.39	4 x 10.0	81	99	110	411	128	75	

BSPP thread available on request.

The maximum tank diameter applies to the recommended operating pressure and is meant as a recommendation only. The cleaning result is also affected by the type of soiling.



Our special mounting bracket provides the ability for the 5TM to reach the far ends of long horizontal tanks/tankers. Mounting bracket part number: **099.164.17.00.00.0**

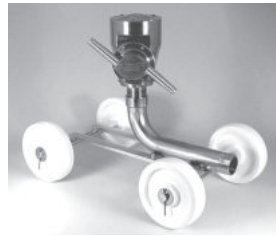

Portable cart for easier transporting of your 5TM from tank to tank. The cart part number is **M20.000.17.BR**. For use with "BR" connection only.

Flushing Nozzle Assembly

Series 597 Lauter Tun



Features:

- Designed for cleaning the plate screen in lauter tun tanks
- Threaded connection



Series 597

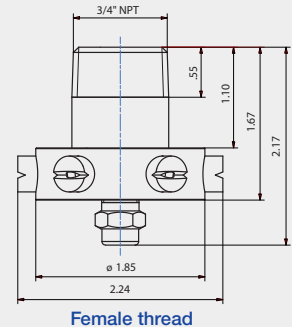

Technical data:



Maximum operating temperature
203 °F



Maximum ambient temperature
392 °F



Installation
Vertically facing upward



Bearing
Static – no bearing



Material
Stainless steel 304 SS,
PTFE



Weight
.20 lb



Surface quality
 $Ra \leq 0.4 \mu m$
OUTSIDE



Surface quality
 $Ra \leq 0.8 \mu m$
INSIDE



Steam suitability
Suitable for short term



Insertion diameter
2.24 in



Recommended filter
Line strainer with a mesh
size of 0.3 mm/50 mesh



Recommended operating pressure
45 psi

Ordering number		V̇ water [gal/min]				
Type	Connection	p [psi]				
	3/4" Female NPT	20	30	Liters per min. 2 bar	45	60
597.085.1C	BK	4.83	5.91	22	7.24	8.36

*Nozzle 490.568.1Y.BA is used in this assembly

Information on operation

- Operation with compressed air purge only for short-term usage. Operation above the recommended operating pressure means higher wear and smaller droplets. This might have adverse effects on the cleaning result.

Extendable cleaning nozzle

PopUp Whirly

Series 5P5

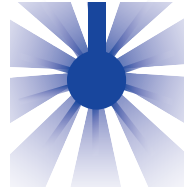

Features:

- Designed for cleaning agitators or other spray shadow areas
- Compact design
- Can be installed flush with the wall



Series 5P5

Technical data:



Maximum operating temperature
203 °F
203 °F (ATEX)



Maximum ambient temperature
302 °F
284 °F (ATEX)



Installation
Operation in every installation position



Bearing
Slide bearing



Material
Stainless steel 1.4404 (316L), stainless steel 1.4571 (316Ti), stainless steel 1.4401 (316), FKM



Weight
.75 lbs



Surface quality
Ra ≤ 0.8 μm on process side, remaining housing Ra ≤ 1.6 μm



Surface quality
Ra ≤ 1.6 μm



Steam suitability
Not suitable



Insertion diameter
1.22 in



Recommended filter
Line strainer with a mesh size of 0.3 mm/50 mesh



Recommended operating pressure
30 psi
Opening pressure: approx. 4 psi, closing pressure: approx. 4 psi



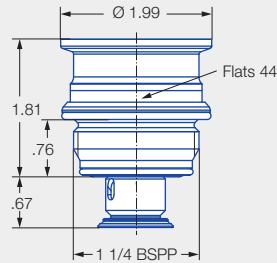

Male thread

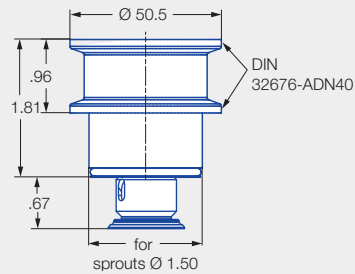

Tri-Clamp connection

Installation situation

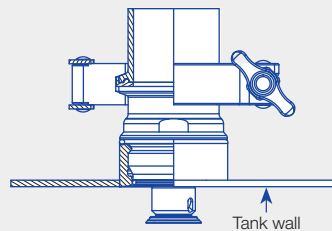

Male thread

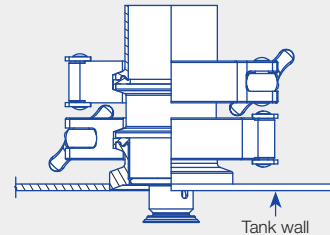

Tri-Clamp connection

Weld-in socket for threaded connection

The thread is hygienically encapsulated with two O-rings (included in the scope of delivery of the PopUp Whirly).

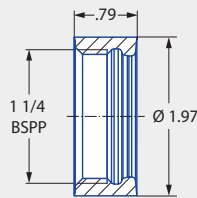

Order no.: 050.020.1Y.AQ.00
Material: Stainless steel 1.4404 (316L)

Weld-in flange for Tri-Clamp connection

A joint clamp in accordance with DIN 32676-A DN50 with a connection diameter of 1.99 in is required for connection of the nozzle at the weld-in flange. A gasket with a thickness of .08 in is required if the flange is used in combination with the PopUp Whirly.

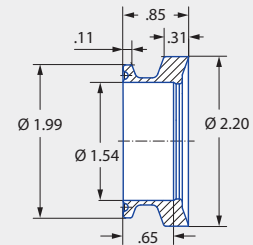

Order no.: 050.020.1Y.01.00
Material: Stainless steel 1.4404 (316L)

Spray angle	Ordering number			Flow Rate (Gallons Per Minute)					Max. tank diameter ft.
	Type	Connection		20 psi	30 psi	Liters per min. 2 bar	40 psi	60 psi	
		G1 1/4A ISO 228	Tri-Clamp						
30°	5P5.081.1Y.00.00.0	AP	00	10.97	13.43	50	15.51	19.00	10

Information on operation

The PopUp Whirly is not suitable for operation with compressed air or another gas. Use above the recommended pressure will have a negative influence on the cleaning result and wear.

*This product is also available in a ATEX version

Rotation monitoring sensor



Features:

Cleaning procedures can be monitored easily and reliably with the Lechler rotation monitoring sensor. The sensor records the quantity of liquid flowing past the sensor tip. With the aid of software¹, the sensor function can be specifically adjusted to the tank size, pressure and nozzle.

Electrical data:

- Supply voltage:
 $U_b = 24\text{ V} \pm 20\%$
 (18 to 32 VDC)
- Power requirements:
 $< 20\text{ mA}$
- Output signal:
 PNP, 50 mA, short circuit protected, active

Operating conditions:

- Ambient temperature:
 $-50\text{ }^\circ\text{F}$ to $+140\text{ }^\circ\text{F}$
- Process temperature:
 $0\text{ }^\circ\text{F}$ to $+212\text{ }^\circ\text{F}$

Materials:

- Socket (1/2 BSPP):
 Stainless steel 316L
- Probe tip: PEEK
- Housing: Stainless steel 303

Operating principle:

- Capacitive

Advantages:

- Reliable recognition of any faults during the cleaning cycle
- The process connection of the sensor is in compliance with the hygiene guidelines of EHEDG
- Simple operation
- Can be connected to a PLC
- Only needs to be set up once using the software provided
- Can be specifically adapted to each cleaning task

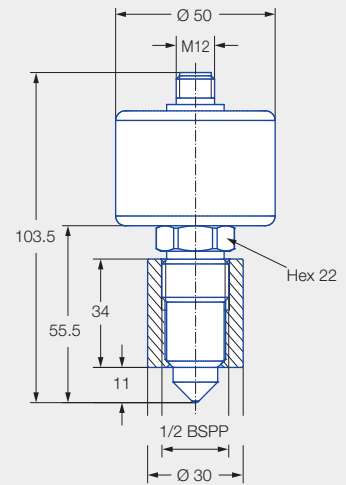

Rotation monitoring sensor, incl. weld-in sleeve



Cable set for commissioning



Mains adapter



USB adapter with cable



Programming adapter Y-piece



Weld-in mandrel

Ordering data	Ordering number
Rotation monitoring sensor, incl. weld-in sleeve	050.040.00.00.00
Cable set for commissioning	050.040.00.00.01

¹ Software download (free): www.lechler.com/software/rotationcontrolsystem

Adapter HygienicFit Series 05C



Features:

- Hygienic threaded connection between equipment and nozzle
- Available for many thread sizes
- Weld-on side suitable for common pipe standards
- O-rings ensure a leak-tight connection
- O-rings fully encapsulate the thread



Series 05C

Technical data:



Maximum operating temperature
302 °F



Maximum ambient temperature
302 °F



Installation
Operation in every installation position



Material
Stainless steel 1.4404 (316L), EPDM (O-ring)



Weight
.15 - .66 lb



Surface quality
Ra ≤ 0.8 µm
OUTSIDE



Surface quality
Ra ≤ 0.8 µm
INSIDE



Steam suitability
Suitable



If you find this icon on our product pages, this means that the nozzle is compatible with the HygienicFit adapter.

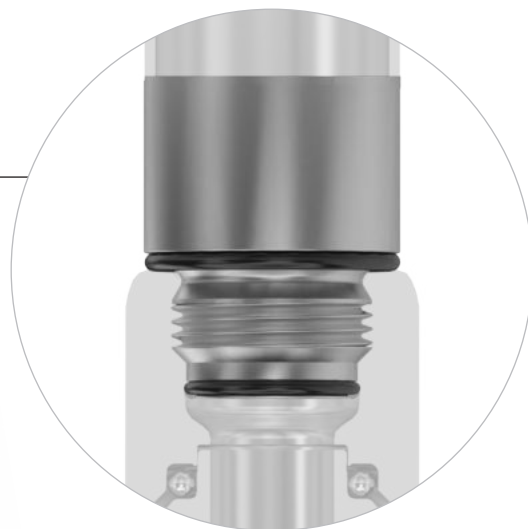

Adapter HygienicFit Series 05C

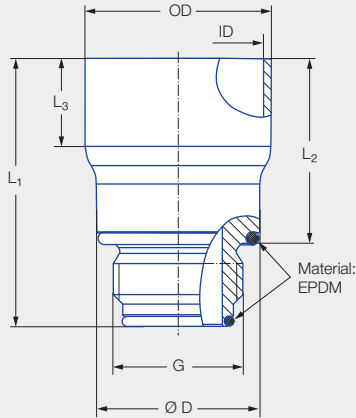
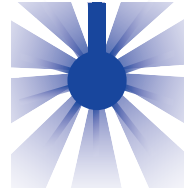

Order number		Dimensions [in]						Pipe standard
Type	Connection thread BSPP Male	L ₁	L ₂	L ₃	Ø D ₁	Ø D ₂	Ø D ₃	
05C.190.1Y.AE.16	3/8	1.89	1.41	0.71	0.75	0.62	0.85	DIN EN 10357 series D
05C.250.1Y.AE.12	3/8	1.89	1.41	0.67	0.98	0.89	0.85	DIN EN 10357 series D
05C.250.1Y.AG.12	1/2	2.20	1.54	0.71	0.98	0.89	1.22	DIN EN 10357 series D
05C.381.1Y.AK.15	3/4	2.17	1.49	0.71	1.50	1.38	1.32	DIN EN 10357 series D
05C.381.1Y.AM.16	1	2.32	1.54	0.91	1.50	1.37	1.59	DIN EN 10357 series D
05C.508.1Y.AP.15	1 1/4	2.24	1.50	0.87	2.00	1.88	1.94	DIN EN 10357 series D
05C.635.1Y.AR.16	1 1/2	2.48	1.73	0.87	2.50	2.37	2.20	DIN EN 10357 series D

Spare parts set of O-rings, EPDM

Thread type BSPP	Order number
3/8	05C.000.E9.AE.00
1/2	05C.000.E9.AG.00
3/4	05C.000.E9.AK.00
1	05C.000.E9.AM.00
1 1/4	05C.000.E9.AP.00
1 1/2	05C.000.E9.AR.00

O-ring set also available in FKM on request.

PERFECT FOR RELIABLE PLANNING

TankClean SIMULATION SOFTWARE



Planning for a perfectly clean tank can be a challenge. Many tanks have built-in equipment such as agitators or baffles which can create spray shadows. Whether a certain nozzle is able to reliably clean all surfaces of the tank under these conditions cannot be decided with certainty on the basis of just a visual inspection.

With our new and unique TankClean software, we can help you to find the optimum solution for perfectly cleaning your tank. To do this, we replicate the tank geometry in the software and then simulate the spraying operation. Operation of all Lechler tank cleaning nozzles can be simulated – from the static spray ball to the high-impact tank cleaning machine. The result of the simulation is documented and provided in a PDF or video file. Simulation with TankClean can be used as the basis for optimum cleaning in the planning phase of new tanks, as well as to optimize existing tank cleaning processes.

Our unique service – your individual benefit

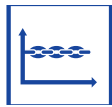

Planning certainty

We assist you in planning your tank cleaning solution to ensure cleaning without any gaps.

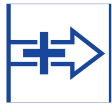

Process optimization

By simulating the existing cleaning processes, we show you the optimization potentials for these processes.



Process reliability

Thanks to realistic and individually customized process simulations, we can offer you individual solution concepts.



Cost and time savings

Simulation makes it possible to detect any potential problem areas before final definition of the cleaning concept. This makes it possible to significantly reduce the number of time- and cost-intensive practical cleaning tests.

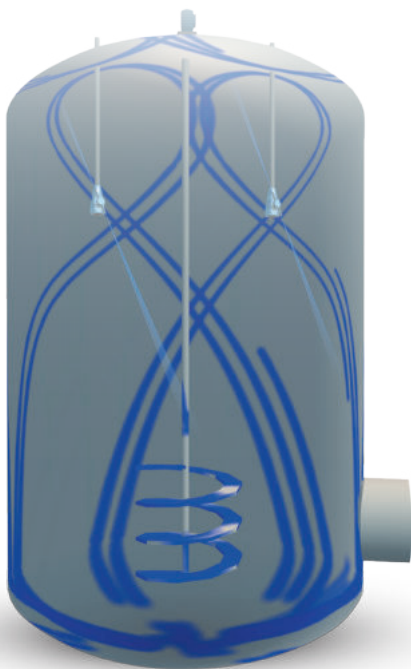

TankClean



Function video

Scan the QR-code or go to:
www.lechler.de/TankCleanGB



Individual adaptation of tank geometries and built-in equipment



Selection of the right tank cleaning nozzles



Realistic simulation of the cleaning process

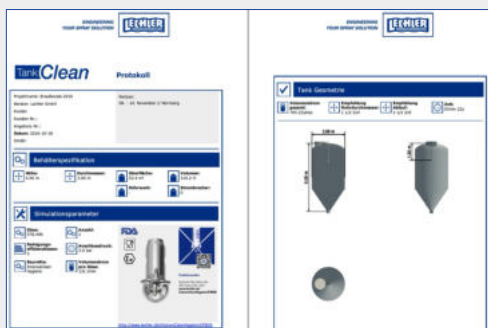

Documentation of the simulation results, including additional planning aids



Talk to us

Are you interested in tank cleaning simulations with TankClean? Ask your Lechler contact person for further information or give us a call. We will gladly help you in planning your tank cleaning solution.

➤ PNEUMATIC ATOMIZING NOZZLES

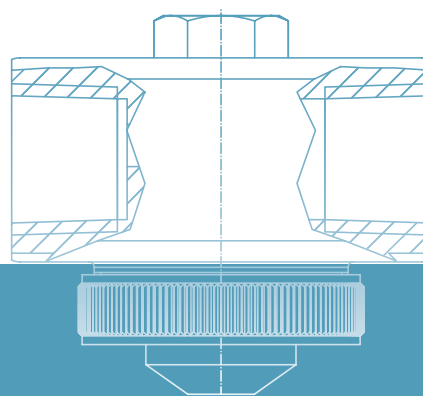

➤ PNEUMATIC ATOMIZING NOZZLES GENERAL INFORMATION

Pneumatic atomizing nozzles produce extremely fine droplets with a small droplet size. There are two options available: Internal Mixing (for lower viscosity fluids) where the mixing of gas and liquid happens inside the nozzle and External Mixing (for higher viscosity fluids) where the mixing of gas and liquid happens outside the nozzle. Depending on the option chosen, the liquid can be gravity/siphon fed or pressurized. Flat fan, full cone and solid stream spray patterns are available.

Pneumatic atomizing nozzles



- Produces extremely fine droplets.
- Wide range of liquid-supply.
- Internal or external mixing.
- Suitable for humidification, cooling and the atomization of viscous fluids.

Liquid pressure principle

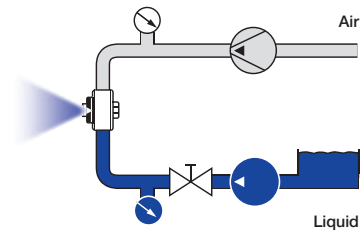



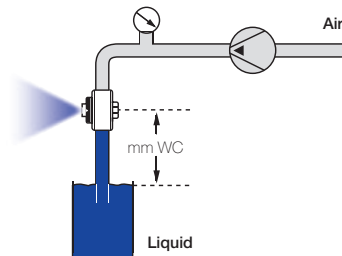

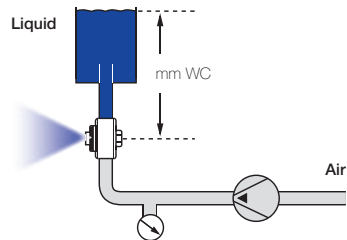

Siphon principle







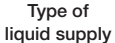
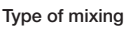

Supply principle











		Pneumatic atomizing nozzles			
					
Series		136.1	136.2	136.3	136.4
Information on page		117	119	120	123
 Spray pattern	Full cone	•	•	•	
	Flat fan				•
	Solid stream				
 Type of liquid supply	Pressure principle	•	•		•
	Siphon and/or supply principle			•	
 Type of mixing	Internal mixing	•	•		•
	External mixing			•	
 Flow rate	gal/h	0.11–24.62	0.11–35.11	0.08–17.63	0.03–20.10
 Spray angle	Small (15°–30°)	•		•	
	Medium (45°)				•
	Large (60°–80°)		•		•

					
136.5	136.6	166.1	166.2	166.4	166.6
125	127	133	135	136	138
		•	•		
•	•			•	•
	•	•	•	•	•
•					
•		•	•	•	
	•				•
0.21-0.85	0.44-26.97	0.11-24.62	0.11-35.11	0.03-20.10	0.44-26.97
		•			
	•			•	•
•	•		•	•	•



PNEUMATIC ATOMIZING NOZZLES OVERVIEW OF SERIES



Pneumatic atomizing nozzles					
					
Series		176 ViscoMist	140	170	150
Information on page		141	140	on request	on request
Spray pattern	Full cone	•	•	•	•
	Flat fan	•			
	Solid stream	•			
Type of liquid supply	Pressure principle	•		•	•
	Siphon and/or supply principle		•		
Type of mixing	Internal mixing		•	•	
	External mixing	•			•
Flow rate 	gal/h	2.06–81.10	1.19–3.17	2.25–76.61 [gal/min]	0.04–16.64 [gal/min]
Spray angle 	Small (15°–30°)	•	•	•	•
	Medium (45°)				
	Large (60°–80°)				

➤ Pneumatic atomizing nozzles, full cone, pressure principle, internal mixing

Series 136.1

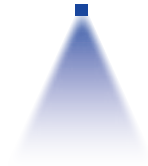

Features:

- Fine full cone atomization
- Liquid pressure principle
- Internal mixing

Applications:

- Humidification of air
- Cooling

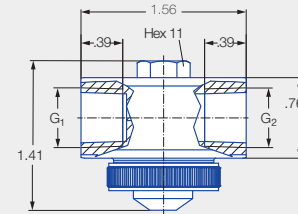

Series 136.1

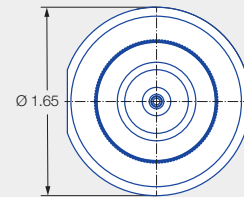
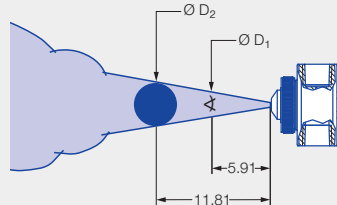

Liquid connection G ₁	Air connection G ₂	Screw plug thread (size 11)	Weight [lb] (Stainless steel 303)
1/4 NPT	1/4 NPT	5/16-24 UNF-2A	0.5

Spray angle	Ordering number		Narrowest free cross section Ø [in]	Liquid pressure p [psi]												Spray dimensions								
	Type	Material number		10				20				40				60				p air [psi]	p water [psi]	Ø D ₁ [in]	Ø D ₂ [in]	
		1Y		16	p air [psi]	V̇ water [gal/h]	V̇ _a air [SCFM]	p air [psi]	V̇ water [gal/h]	V̇ _a air [SCFM]	p air [psi]	V̇ water [gal/h]	V̇ _a air [SCFM]	p air [psi]	V̇ water [gal/h]	V̇ _a air [SCFM]								
20°	136.115.xx.B2	●	●	0.2	6	1.6	0.18	20	1.5	.47	35	2.4	0.6	44	2.9	0.7	12	10	2	4				
					12	1.0	0.35	26	1.1	.59	41	2.0	0.7	49	2.5	0.8	26	22	2	4				
		17	.45		0.53	32	.58	.82	46	1.6	0.9	55	2.2	0.9	38	29	2	4						
		-	-		-	38	.32	1.0	52	1.2	1.1	61	1.8	1.1	46	44	2	4						
		-	-		-	-	-	-	58	0.8	1.2	67	1.5	1.3	64	58	2	4						
		-	-		-	-	-	-	64	0.5	1.5	73	1.1	1.5	-	-	-	-						
		-	-		-	-	-	-	70	0.3	1.6	78	0.8	1.6	-	-	-	-						
		-	-		-	-	-	-	76	0.1	1.8	84	0.6	1.8	-	-	-	-						
		-	-		-	-	-	-	-	-	-	-	-	-	-	-	-	-						
		-	-		-	-	-	-	-	-	-	-	-	-	-	-	-	-						
	136.125.xx.B2	●	●	0.5	12	1.3	0.9	17	1.8	1.1	41	2.4	1.9	49	2.8	2.3	20	10	2	4				
					17	1.2	1.1	23	1.7	1.3	46	2.3	2.2	55	2.7	2.5	32	22	2	4				
		23	1.1		1.4	29	1.6	1.5	52	2.2	2.4	61	2.6	2.7	41	29	2	4						
		29	0.9		1.5	35	1.5	1.8	58	2.1	2.6	67	2.5	2.9	49	44	2	4						
		35	0.8		1.8	41	1.4	2.0	64	2.0	2.8	73	2.4	3.2	61	58	2	4						
		41	0.7		1.9	46	1.3	2.2	70	1.9	3.1	78	2.3	3.4	-	-	-	-						
		46	0.5		2.2	52	1.2	2.4	75	1.8	3.3	84	2.2	3.6	-	-	-	-						
		52	0.4		2.4	58	1.0	2.6	81	1.7	3.5	-	-	-	-	-	-	-						
		58.0	0.3		3	63.8	0.9	3	87	1.6	4	-	-	-	-	-	-	-						
		63.8	0.3		3	69.6	0.8	3	-	-	-	-	-	-	-	-	-	-						
69.6	0.2	3	75.4	0.7	3	-	-	-	-	-	-	-	-	-	-									
-	-	-	81.2	0.6	3	-	-	-	-	-	-	-	-	-	-									
-	-	-	87.0	0.5	4	-	-	-	-	-	-	-	-	-	-									





Spray angle	Ordering number		Narrowest free cross section Ø [in]	Liquid pressure p [psi]												Spray dimensions				
	Type	Material number		10			20			40			60			p water [psi]	Ø D ₁ [in]	Ø D ₂ [in]		
		1Y		16	p air [psi]	V̇ water [gal/h]	V̇ _{air} [SCFM]	p air [psi]	V̇ water [gal/h]	V̇ _{air} [SCFM]	p air [psi]	V̇ water [gal/h]	V̇ _{air} [SCFM]	p air [psi]	V̇ water [gal/h]				V̇ _{air} [SCFM]	
		Stainless steel 316L		Stainless steel 303																
20°	136.134.xx.B2	●	●	0.03	17	3.5	1.6	29	5.1	2.3	44	7.5	3.1	55	9.6	3.6	26	10	2	4
					23	3.3	1.9	35	4.8	2.6	49	7.2	3.4	61	8.4	4.0	41	22	2	4
					29	3.1	2.3	41	4.6	2.9	55	7.0	3.7	67	8.2	4.3	55	29	2	4
					35	3.0	2.6	46	4.4	3.2	61	6.8	4.0	73	8.1	4.6	75	44	3	4
					41	2.9	2.9	52	4.2	3.5	67	6.6	4.3	78	7.9	4.9	87	58	3	4
					46	2.8	3.2	58	4.1	3.8	73	6.4	4.6	84	7.7	5.2	-	-	-	-
					52	2.8	3.5	64	4.0	4.1	78	6.2	4.9	-	-	-	-	-	-	-
					58	2.7	3.8	70	3.9	4.5	84	6.1	5.2	-	-	-	-	-	-	-
					64	2.6	4.1	75	3.8	4.8	-	-	-	-	-	-	-	-	-	-
	70	2.6	4.5	81	3.7	5.1	-	-	-	-	-	-	-	-	-	-				
	75	2.5	4.8	87	3.6	5.4	-	-	-	-	-	-	-	-	-	-				
	81	2.4	5.1	-	-	-	-	-	-	-	-	-	-	-	-	-				
	87	2.2	5.4	-	-	-	-	-	-	-	-	-	-	-	-	-				
	136.142.xx.B2	●	●	0.10	20	6.4	3.0	23	14.1	2.8	46	18.7	4.7	55	24.6	5.4	12	10	2	4
					26	5.4	3.7	29	11.2	3.5	52	16.5	5.4	61	22.0	5.9	23	22	3	4
					32	5.3	4.2	35	9.3	4.2	58	14.7	6.2	67	19.9	6.7	44	29	2	4
					38	5.1	4.8	41	8.0	4.9	64	13.0	6.9	73	18.2	7.4	58	44	3	4
					44	4.6	5.5	46	7.5	5.6	70	11.8	7.6	78	16.8	8.1	87	58	3	4
49					4.3	6.1	52	7.4	6.2	75	11.1	8.3	84	15.2	8.8	-	-	-	-	
55					4.5	6.7	58	7.2	6.8	81	10.7	8.9	-	-	-	-	-	-	-	
61					4.3	7.3	64	6.8	7.4	87	10.5	9.5	-	-	-	-	-	-	-	
67					3.9	7.8	70	6.4	7.9	-	-	-	-	-	-	-	-	-	-	
73					3.7	8.4	75	5.9	8.6	-	-	-	-	-	-	-	-	-	-	
78	3.4	9.0	81	5.7	9.2	-	-	-	-	-	-	-	-	-	-					
84	3.3	9.5	87	5.6	9.8	-	-	-	-	-	-	-	-	-	-					

Ordering Type + Material no. = Ordering no.
 example: 136.134.xx.B2 + 1Y = 136.134.1Y.B2

➤ Pneumatic atomizing nozzles, wide full cone, pressure principle, internal mixing

Series 136.2



Features:

- Fine full cone atomization
- Liquid pressure principle
- Internal mixing
- Extra wide spray angle of 60°

Applications:

- Humidification
- Cooling

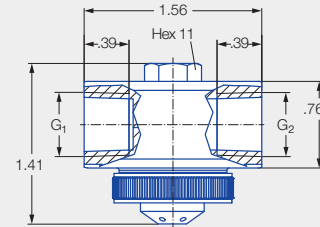

Series 136.2

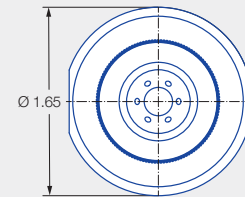
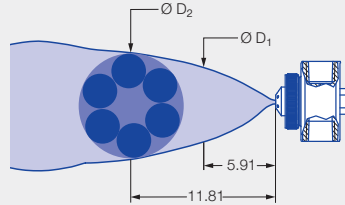

Liquid connection G ₁	Air connection G ₂	Screw plug thread (size 11)	Weight [lb] (Stainless steel 303)
1/4 NPT	1/4 NPT	5/16-24 UNF-2A	0.5

Spray angle	Ordering number			Narrowest free cross section Ø [in]	Liquid pressure p [psi]												Spray dimensions							
	Type	Material number			10				20				40				60				p air [psi]	p water [psi]	Ø D ₁ [in]	Ø D ₂ [in]
		1Y	16		p air [psi]	V̇ water [gal/h]	V̇ air [SCFM]	p air [psi]	V̇ water [gal/h]	V̇ air [SCFM]	p air [psi]	V̇ water [gal/h]	V̇ air [SCFM]	p air [psi]	V̇ water [gal/h]	V̇ air [SCFM]								
60°	136.215.xx.B2	●	●	0.02	15	0.8	0.8	23	1.5	1.0	41	2.2	1.4	55	2.5	1.8	15	10	8	13				
					17	0.5	0.9	26	1.3	1.1	46	1.9	1.6	61	2.2	2.1	23	22	9	15				
					20	0.2	1.1	29	1.0	1.2	52	1.5	1.9	67	1.8	2.3	35	29	9	15				
					-	-	-	32	0.7	1.4	58	1.1	2.1	73	1.4	2.5	46	44	10	15				
					-	-	-	35	0.4	1.5	64	0.6	2.4	78	1.0	2.8	61	58	10	16				
					-	-	-	38	0.2	1.6	70	0.2	2.6	84	0.6	3.1	-	-	-	-				
					-	-	-	-	-	-	73	0.1	2.7	87	0.4	3.3	-	-	-	-				
	136.222.xx.B2	●	●	0.04	12	4.6	1.6	23	6.8	2.4	44	10.7	3.4	55	14.5	3.8	12	10	10	18				
					15	1.6	2.5	26	3.9	3.1	46	8.3	4.1	58	12.0	4.3	23	22	10	18				
					-	-	-	29	1.8	3.9	49	5.9	4.8	61	9.9	5.0	33	29	10	18				
					-	-	-	32	0.5	4.8	52	3.9	5.6	64	7.8	5.7	46	44	10	18				
					-	-	-	-	-	-	55	2.2	6.5	67	5.7	6.6	61	58	10	18				
					-	-	-	-	-	-	58	1.2	7.2	70	4.0	7.3	-	-	-	-				
					-	-	-	-	-	-	-	-	73	2.6	8.1	-	-	-	-					
					-	-	-	-	-	-	-	-	75	1.6	8.9	-	-	-	-					
					-	-	-	-	-	-	-	-	78	0.8	9.7	-	-	-	-					
					136.231.xx.B2	●	●	0.06	23	6.8	3.0	38	11.7	4.1	52	24.8	4.6	61	35.1	4.3	29	10	9	15
	29	4.7	3.6	44					8.7	4.8	58	20.7	5.5	67	31.0	5.3	38	22	10	16				
	35	3.0	4.2	49					6.5	5.4	64	17.4	6.2	73	26.7	6.1	35	29	10	17				
	41	1.8	4.8	55					4.8	6.0	70	14.5	7.0	78	23.2	6.9	52	44	10	17				
	-	-	-	61					3.5	6.6	75	12.0	7.7	84	20.2	7.8	61	58	10	17				
	-	-	-	67					2.5	7.1	81	10.0	8.3	87	18.8	8.1	-	-	-	-				
	-	-	-	-					-	-	87	9.5	8.5	-	-	-	-	-	-	-				

Ordering Type + Material no. = Ordering no.
 example: 136.215.xx.B2 + 1Y = 136.215.1Y.B2

➤ Pneumatic atomizing nozzles, full cone, siphon principle, external mixing Series 136.3

Features:

- Particularly fine full cone atomization
- Gravity/Siphon principle
- External mixing

Applications:

- Cooling
- Atomization of viscous liquids
- Chemical industry

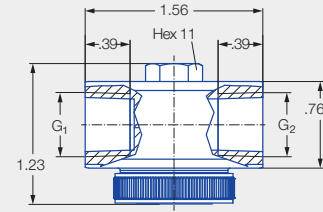

Series 136.3

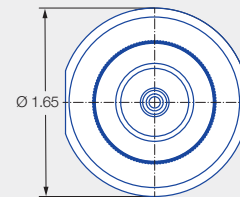
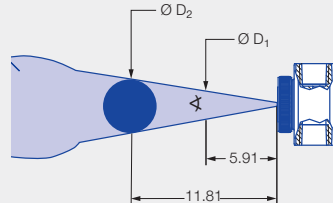

Liquid connection G ₁	Air connection G ₂	Screw plug thread (size 11)	Weight [lb] (Stainless steel 303)
1/4 NPT	1/4 NPT	5/16-24 UNF-2A	0.5

Spray angle	Ordering number		Narrowest free cross section Ø [in]	Air		V̇ water [gal/h]					Spray dimensions							
	Type	Material number		p [psig]	V̇ _n [SCFM]	Water column [in WC]			Aspiration height [in WC]		p _{air} [psig]	Aspiration height [in WS]	Ø D ₁ [in]	Ø D ₂ [in]				
		1Y				16	6	12	18	4					8	12	24	35
20°	136.316.xx.B2	●	●	0.02	9	0.4	–	0.4	0.3	–	–	–	–	–	20	12	2	4
					12	0.5	0.3	0.4	0.4	–	–	–	–	–	46	12	2	5
					17	0.6	0.4	0.4	0.4	0.3	0.2	–	–	–	70	12	3	5
					20	0.7	0.4	0.4	0.4	0.3	0.3	0.2	–	–	87	12	3	5
					26	0.8	0.4	0.5	0.5	0.3	0.3	0.2	–	–	–	–	–	–
					29	0.9	0.4	0.5	0.5	0.3	0.3	0.3	–	–	–	–	–	–
					35	1.1	0.5	0.5	0.5	0.4	0.3	0.3	0.1	–	–	–	–	–
					38	1.1	0.5	0.5	0.5	0.4	0.3	0.3	0.2	–	–	–	–	–
					44	1.2	0.5	0.5	0.5	0.4	0.4	0.3	0.2	0.1	–	–	–	–
					46	1.3	0.5	0.6	0.5	0.4	0.4	0.4	0.3	0.1	–	–	–	–
					52	1.4	0.5	0.6	0.6	0.5	0.4	0.4	0.3	0.2	–	–	–	–
					55	1.5	0.6	0.6	0.6	0.5	0.5	0.4	0.3	0.2	–	–	–	–
					61	1.6	0.6	0.6	0.6	0.5	0.5	0.4	0.4	0.3	–	–	–	–
					64	1.7	0.6	0.6	0.6	0.5	0.5	0.5	0.4	0.3	–	–	–	–
					70	1.8	0.6	0.6	0.6	0.5	0.5	0.5	0.4	0.3	–	–	–	–
					73	1.9	0.6	0.6	0.6	0.5	0.5	0.5	0.4	0.2	–	–	–	–
					78	2.0	0.6	0.6	0.6	0.5	0.4	0.4	0.3	0.1	–	–	–	–
81	2.1	0.5	0.6	0.6	0.5	0.4	0.4	0.2	–	–	–	–	–					
87	2.2	0.5	0.6	0.5	0.4	0.4	0.3	–	–	–	–	–	–					



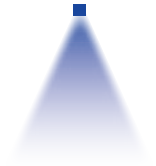

Spray angle	Ordering number		Narrowest free cross section Ø [in]	Air		V̇ water [gal/h]					Spray dimensions								
	Type	Material number		p [psi]	V̇ _a [SCFM]	Water column [in WC]			Aspiration height [in WC]		p _{air} [psi]	Aspiration height [in WS]	Ø D ₁ [in]	Ø D ₂ [in]					
		1Y				16	6	12	18	4					8	12	24	35	
		Stainless steel 316L				Stainless steel 303													
20°	136.324.xx.B2	●	●	0.03	12	0.5	-	-	-	0.7	0.5	-	-	-	17	12	2	5	
					17	0.6	-	-	-	0.8	0.7	0.5	-	-	46	12	3	5	
					20	0.7	-	-	-	0.9	0.7	0.6	-	-	70	12	3	5	
					26	0.9	-	-	-	1.0	0.9	0.7	-	-	87	12	3	5	
					29	0.9	-	-	-	1.0	0.9	0.8	0.2	-	-	-	-	-	-
					35	1.1	-	-	-	1.1	1.0	0.8	0.4	-	-	-	-	-	-
					38	1.1	-	-	-	1.2	1.0	0.9	0.4	-	-	-	-	-	-
					44	1.2	1.4	-	-	1.2	1.1	1.0	0.5	-	-	-	-	-	-
					46	1.3	1.5	-	-	1.3	1.1	1.0	0.6	-	-	-	-	-	-
					52	1.4	1.5	-	-	1.3	1.2	1.1	0.7	-	-	-	-	-	-
	55	1.5	1.6	-	-	1.4	1.2	1.2	0.8	0.6	-	-	-	-	-				
	61	1.6	1.7	1.8	-	1.5	1.4	1.2	0.8	0.8	-	-	-	-	-				
	64	1.7	1.7	1.8	1.9	1.6	1.4	1.3	1.0	0.8	-	-	-	-	-				
	70	1.8	1.7	1.7	1.8	1.6	1.4	1.4	1.0	0.5	-	-	-	-	-				
	73	1.9	1.6	1.7	1.8	1.6	1.4	1.3	1.1	-	-	-	-	-	-				
	78	2.0	1.5	1.6	1.7	1.5	1.3	1.2	1.0	-	-	-	-	-	-				
	81	2.1	1.5	1.6	1.7	1.4	1.3	1.2	1.0	-	-	-	-	-	-				
	87	2.2	1.4	1.5	1.6	1.3	1.2	1.1	0.5	-	-	-	-	-	-				
		136.334.xx.B2	●	●	0.03	9	0.7	-	-	-	0.6	-	-	-	-	12	12	65	5
						12	0.8	-	-	-	0.7	0.6	0.4	-	-	46	12	65	5
17						1.1	-	-	-	0.9	0.8	0.7	0.2	-	70	12	70	5	
20						1.2	-	-	-	1.0	0.9	0.8	0.3	-	87	12	75	5	
26						1.4	1.4	-	-	1.1	1.0	0.9	0.6	-	-	-	-	-	-
29						1.5	1.4	1.6	1.7	1.2	1.1	1.0	0.7	0.2	-	-	-	-	-
35						1.6	1.5	1.7	1.8	1.3	1.2	1.1	0.9	0.4	-	-	-	-	-
38						1.8	1.6	1.7	1.8	1.3	1.2	1.2	0.9	0.5	-	-	-	-	-
44						2.0	1.7	1.8	1.9	1.4	1.3	1.2	1.0	0.6	-	-	-	-	-
46						2.1	1.7	1.8	1.9	1.5	1.4	1.3	1.1	0.7	-	-	-	-	-
52						2.3	1.8	1.9	2.0	1.5	1.5	1.4	1.1	0.9	-	-	-	-	-
55						2.4	1.8	1.9	2.1	1.6	1.5	1.4	1.2	1.0	-	-	-	-	-
61						2.6	1.9	2.1	2.2	1.7	1.6	1.5	1.3	1.1	-	-	-	-	-
64						2.7	2.0	2.2	2.3	1.8	1.7	1.6	1.4	1.2	-	-	-	-	-
70						2.9	2.2	2.3	2.4	1.9	1.8	1.8	1.5	1.3	-	-	-	-	-
73						3.0	2.3	2.3	2.4	2.0	1.9	1.9	1.6	1.4	-	-	-	-	-
78						3.2	2.2	2.3	2.3	2.0	2.0	1.9	1.7	1.5	-	-	-	-	-
81						3.3	2.2	2.2	2.3	2.0	2.0	1.9	1.7	1.5	-	-	-	-	-
87	3.5	2.1	2.2	2.2	1.9	1.9	1.8	1.6	1.5	-	-	-	-	-					





Spray angle	Ordering number		Narrowest free cross section Ø [in]	Air		V̇ water [gal/h]					Spray dimensions							
	Type	Material number		p [psi]	V̇ _a [SCFM]	Water column [in WC]			Aspiration height [in WC]		p _{air} [psi]	Aspiration height [in WS]	Ø D ₁ [in]	Ø D ₂ [in]				
		1Y				16	6	12	18	4					8	12	24	35
		Stainless steel 316L				Stainless steel 303												
20°	136.342.xx.B2	●	●	0.06	20	2.1	-	-	-	2.3	-	-	1.0	-	26	300	3	5
					26	2.5	-	-	-	2.5	2.2	2.0	1.4	0.9	44	300	3	5
					29	2.6	3.2	-	-	2.6	2.4	2.1	1.5	1.1	61	300	3	5
					35	3.1	3.2	-	-	2.7	2.5	2.3	1.8	1.4	87	300	3	5
					38	3.2	3.2	3.5	-	2.8	2.6	2.4	1.9	1.5	-	-	-	-
					44	3.6	3.2	3.5	3.7	2.8	2.7	2.5	2.0	1.7	-	-	-	-
					46	3.8	3.2	3.5	3.7	2.8	2.7	2.5	2.1	1.8	-	-	-	-
					52	4.1	3.3	3.5	3.7	2.9	2.8	2.7	2.3	2.1	-	-	-	-
					55	4.3	3.3	3.5	3.7	3.0	2.9	2.8	2.5	2.2	-	-	-	-
					61	4.7	3.5	3.7	3.8	3.2	3.1	3.0	2.8	2.6	-	-	-	-
					64	4.9	3.6	3.7	3.9	3.3	3.2	3.1	2.9	2.7	-	-	-	-
					70	5.2	3.7	3.8	4.0	3.4	3.3	3.2	3.0	2.7	-	-	-	-
					73	5.4	3.7	3.8	4.0	3.4	3.3	3.2	2.9	2.7	-	-	-	-
					78	5.8	3.6	3.8	3.9	3.3	3.2	3.1	2.8	2.4	-	-	-	-
	81	5.9	3.5	3.7	3.9	3.2	3.1	3.0	2.7	2.3	-	-	-	-				
	87	6.4	3.2	3.4	-	2.9	2.8	2.7	2.3	1.9	-	-	-	-				
	136.351.xx.B2	●	●	0.10	46	6.8	-	-	-	-	10.3	-	-	-	55	12	4	5
					52	7.4	-	-	-	12.1	11.1	-	8.8	-	67	12	4	6
					55	7.7	-	-	-	12.6	11.9	11.2	9.3	-	78	12	4	6
					61	8.4	-	-	-	13.6	13.0	12.3	10.5	7.9	87	12	4	6
64					8.7	-	-	-	14.0	13.4	12.8	11.0	8.3	-	-	-	-	
70					9.4	-	16.7	-	14.6	14.1	13.5	11.9	9.2	-	-	-	-	
73					9.7	-	16.8	17.6	14.8	14.3	13.8	12.2	9.5	-	-	-	-	
78					10.4	16.1	17.0	17.6	15.0	14.5	14.0	12.6	10.0	-	-	-	-	
81					10.7	16.1	16.9	17.6	15.0	14.5	14.1	12.6	10.2	-	-	-	-	
87					11.3	15.8	16.6	17.3	14.7	14.3	13.8	12.1	9.8	-	-	-	-	

Ordering Type + Material no. = Ordering no.
 example: 136.342.xx.B2 + 1Y = 136.342.1Y.B2

➤ Pneumatic atomizing nozzles, wide flat fan, pressure principle, internal mixing

Series 136.4



Features:

- Fine flat fan atomization
- Pressure principle
- Internal mixing

Applications:

- Humidification of goods
- Cooling
- Belt humidification



Series 136.4

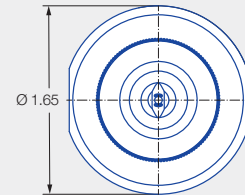
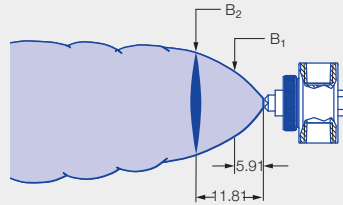
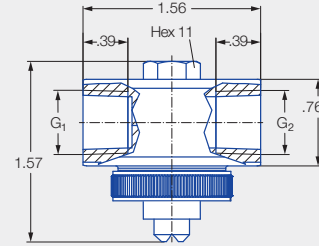

Liquid connection G ₁	Air connection G ₂	Screw plug thread (size 11)	Weight [lb] (Stainless steel 303)
1/4 NPT	1/4 NPT	5/16-24 UNF-2A	0.5

Spray angle	Ordering number		Narrowest free cross section Ø [in]	Liquid pressure p [psi]												Spray dimensions				
	Type	Material number		10			20			40			60			p water [psi]	B ₁ [in]	B ₂ [in]		
		1Y		16	p air [psi]	v̇ water [gal/h]	v̇ air [SCFM]	p air [psi]	v̇ water [gal/h]	v̇ air [SCFM]	p air [psi]	v̇ water [gal/h]	v̇ air [SCFM]	p air [psi]	v̇ water [gal/h]				v̇ air [SCFM]	
45°	136.414.xx.B2	●	●	0.03	15	2.0	0.8	20	3.8	0.9	32	5.9	1.2	44	6.6	1.5	20	10	3	5
					17	1.6	0.9	23	3.4	0.9	38	5.3	1.4	49	6.1	1.6	35	22	4	6
					20	1.1	1.0	26	3.1	1.1	44	4.7	1.5	55	5.5	1.8	46	29	4	6
					23	0.7	1.1	29	2.7	1.2	49	4.1	1.8	61	5.0	2.1	55	44	5	7
					26	0.3	1.2	32	2.4	1.3	55	3.5	2.0	67	4.5	2.2	67	58	5	8
					-	-	-	35	2.0	1.4	61	2.9	2.2	73	3.9	2.5	-	-	-	-
					-	-	-	38	1.6	1.5	67	2.3	2.4	78	3.4	2.7	-	-	-	-
					-	-	-	41	1.2	1.6	73	1.7	2.6	84	2.9	2.9	-	-	-	-
	-	-	-	44	0.8	1.8	78	1.1	2.9	87	2.6	3.1	-	-	-	-				
	-	-	-	46	0.6	1.9	84	0.7	3.1	-	-	-	-	-	-	-				
	-	-	-	49	0.3	2.0	87	0.4	3.2	-	-	-	-	-	-	-				
	136.443.xx.B2	●	●	0.04	17	3.7	0.9	23	7.0	0.9	44	9.8	1.5	52	12.0	1.7	17	10	4	6
					20	3.1	1.0	26	6.4	1.1	49	8.7	1.8	58	11.1	1.9	29	22	5	7
					23	2.5	1.1	29	5.8	1.2	55	7.8	2.0	64	10.1	2.2	41	29	6	7
					26	2.1	1.2	32	5.3	1.3	61	6.9	2.2	70	9.2	2.4	55	44	6	8
					-	-	-	35	4.8	1.4	67	6.1	2.5	75	8.4	2.6	70	58	6	9
-					-	-	38	4.3	1.5	73	5.3	2.7	81	7.7	2.9	-	-	-	-	
-					-	-	41	3.8	1.6	78	4.6	2.9	87	6.9	3.1	-	-	-	-	
-					-	-	44	3.4	1.8	84	3.9	3.1	-	-	-	-	-	-	-	
-					-	-	46	3.0	1.9	87	3.7	3.2	-	-	-	-	-	-	-	
-					-	-	49	2.6	2.0	-	-	-	-	-	-	-	-	-	-	
-					-	-	52	2.3	3.6	-	-	-	-	-	-	-	-	-	-	





Spray angle	Ordering number		Narrowest free cross section \varnothing [in]	Liquid pressure p [psi]												Spray dimensions				
	Type	Material number		10			20			40			60			p water [psi]	B ₁ [in]	B ₂ [in]		
		1Y		16	p air [psi]	\dot{V} water [gal/h]	\dot{V} air [SCFM]	p air [psi]	\dot{V} water [gal/h]	\dot{V} air [SCFM]	p air [psi]	\dot{V} water [gal/h]	\dot{V} air [SCFM]	p air [psi]	\dot{V} water [gal/h]				\dot{V} air [SCFM]	
		Stainless steel 316L		Stainless steel 303																
45°	136.462.xx.B2	●	●	0.06	17	5.0	1.5	29	5.8	1.2	44	16.3	2.4	55	20.1	2.7	17	10	5	6
					23	3.2	2.0	35	4.8	1.4	49	13.7	2.8	58	18.6	3.0	35	22	5	7
					29	2.5	2.4	41	3.8	1.6	55	11.8	3.4	61	17.3	3.2	46	29	5	7
					35	1.9	2.8	46	3.0	1.9	61	10.3	3.9	64	16.2	3.5	55	44	6	8
					41	1.5	3.2	52	2.3	2.1	67	8.8	4.4	67	15.1	3.8	87	58	6	8
					46	1.3	3.5	58	2.1	2.3	73	7.8	4.8	70	14.3	3.9	-	-	-	-
					52	1.0	3.9	64	1.64	2.5	78	6.74	5.2	73	13.6	4.2	-	-	-	-
					58	0.8	4.2	70	1.2	2.7	84	5.8	5.7	75	13.0	4.5	-	-	-	-
					64	0.6	4.6	75	0.8	2.9	87	5.4	5.8	78	12.3	4.8	-	-	-	-
					-	-	-	81	0.4	3.1	-	-	-	81	11.5	5.1	-	-	-	-
					-	-	-	84	0.2	3.2	-	-	-	84	10.9	5.2	-	-	-	-
					-	-	-	-	-	-	-	-	-	87	10.3	5.5	-	-	-	-
60°	136.425.xx.B2	●	●	0.02	12	1.7	0.7	20	2.5	1.0	35	3.5	1.5	35	4.3	1.5	17	10	6	8
					17	1.5	0.9	26	2.3	1.2	38	3.4	1.6	41	4.1	1.7	32	22	6	10
					23	1.2	1.1	32	2.1	1.4	44	3.2	1.8	46	4.0	1.9	44	29	7	10
					29	1.1	1.4	38	1.9	1.6	49	3.1	2.0	52	3.8	2.1	49	44	8	13
					35	0.8	1.5	44	1.7	1.8	55	2.9	2.2	58	3.7	2.2	81	58	8	13
					41	0.7	1.7	49	1.5	2.0	61	2.7	2.4	64	3.5	2.4	-	-	-	-
					44	0.6	1.8	55	1.3	2.2	67	2.6	2.5	70	3.4	2.6	-	-	-	-
					-	-	-	58	1.3	2.3	73	2.4	2.7	75	3.2	2.8	-	-	-	-
					-	-	-	64	1.1	2.5	78	2.3	2.9	81	3.1	3.0	-	-	-	-
					-	-	-	70	1.0	2.6	84	2.1	3.1	87	3.0	3.2	-	-	-	-
					-	-	-	75	0.7	2.8	87	2.1	3.2	-	-	-	-	-	-	-
					-	-	-	81	0.6	3.0	-	-	-	-	-	-	-	-	-	-
	-	-	-	87	0.4	3.2	-	-	-	-	-	-	-	-	-	-				
	136.452.xx.B2	●	●	0.06	15	5.0	2.3	26	8.2	3.1	46	13.2	4.5	55	18.7	4.8	15	10	5	7
					20	2.3	3.4	29	6.7	3.7	52	10.4	5.5	61	15.5	5.7	26	22	6	9
					26	2.0	4.1	32	5.3	4.2	58	8.3	6.6	67	12.8	6.6	38	29	6	10
					32	1.1	4.9	35	4.1	4.7	64	6.3	7.6	73	10.9	7.7	52	44	7	11
					38	0.3	5.8	38	3.3	5.2	70	4.7	8.5	78	8.9	8.7	73	58	7	11
					41	0.03	6.1	41	2.7	5.7	75	3.5	9.4	84	7.3	9.7	-	-	-	-
					-	-	-	-	-	-	81	2.8	10.3	87	6.4	10.1	-	-	-	-
-					-	-	-	-	-	87	2.3	11.1	-	-	-	-	-	-	-	
136.433.xx.B2	●	●	0.02	15	3.1	1.2	26	4.8	1.6	44	8.2	2.2	55	9.9	2.6	20	10	6	8	
				17	2.1	1.4	29	4.0	1.9	49	6.7	2.6	61	8.6	2.9	32	22	7	10	
				20	1.4	1.6	32	3.2	2.1	55	5.4	3.0	67	7.3	3.4	44	29	8	12	
				23	1.0	1.9	35	2.6	2.4	61	4.3	3.5	73	6.2	3.8	55	58	12	19	
				-	-	-	38	2.0	2.5	67	3.3	3.9	78	5.1	4.2	75	58	10	16	
				-	-	-	41	1.6	2.8	73	2.5	4.3	84	4.2	4.6	-	-	-	-	
				-	-	-	44	1.2	2.9	78	1.7	4.7	87	3.8	4.9	-	-	-	-	

Ordering Type + Material no. = Ordering no.
 example: 136.462.xx.B2 + 1Y = 136.462.1Y.B2



➤ Pneumatic atomizing nozzles, wide flat fan, siphon principle, internal mixing

Series 136.5



Features:

- Particularly fine flat fan atomization
- Siphon principle
- Internal mixing

Applications:

- Humidification of goods
- Cooling
- Belt humidification



Series 136.5

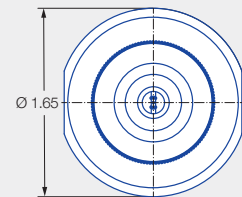
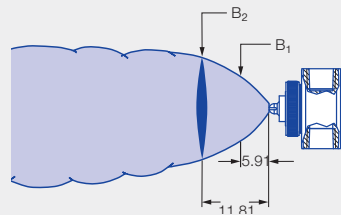
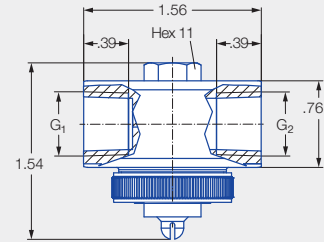

Liquid connection G ₁	Air connection G ₂	Screw plug thread (size 11)	Weight [lb] (Stainless steel 303 SS)
1/4 NPT	1/4 NPT	5/16-24 UNF-2A	0.5

Spray angle	Ordering number		Narrowest free cross section Ø [in]	Air		V̇ water [gal/h]					Spray dimensions							
	Type	Material number		p [psf]	V̇ _a [SCFM]	Water column [in WC]			Aspiration height [in WC]		p air [psf]	Aspiration height [in WS]	B ₁ [in]	B ₂ [in]				
		1Y				16	6	12	18	4					8	12	24	35
60°	136.516.xx.B2	●	●	0.02	12	1.1	-	-	-	0.4	0.4	-	1.17	0.3	15	12	5	6
					17	1.3	0.5	0.6	0.6	0.5	0.5	0.4	1.41	0.4	44	12	6	8
					20	1.5	0.5	0.6	0.6	0.5	0.5	0.4	1.47	0.4	67	12	7	9
					26	1.7	0.5	0.6	0.6	0.5	0.5	0.5	1.53	0.4	87	12	7	9
					29	1.8	0.5	0.6	0.6	0.5	0.5	0.4	1.50	0.4	-	-	-	-
					35	2.1	0.5	0.6	0.6	0.5	0.5	0.4	1.47	0.4	-	-	-	-
					38	2.2	0.5	0.6	0.6	0.5	0.5	0.4	1.44	0.4	-	-	-	-
					44	2.5	0.5	0.5	0.6	0.5	0.4	0.4	1.44	0.4	-	-	-	-
					46	2.6	0.5	0.5	0.6	0.4	0.4	0.4	1.59	0.4	-	-	-	-
					52	2.8	0.5	0.5	0.6	0.5	0.5	0.5	1.68	0.4	-	-	-	-
					55	2.9	0.5	0.5	0.6	0.5	0.5	0.5	1.71	0.5	-	-	-	-
					61	3.2	0.5	0.5	0.6	0.5	0.5	0.5	1.68	0.4	-	-	-	-
					64	3.4	0.5	0.5	0.6	0.5	0.5	0.5	1.74	0.5	-	-	-	-
					70	3.6	0.5	0.5	0.6	0.5	0.5	0.5	2.04	0.5	-	-	-	-
					73	3.7	0.6	0.6	0.6	0.6	0.6	0.6	2.10	0.6	-	-	-	-
					78	4.0	0.6	0.6	0.6	0.6	0.6	0.6	2.04	0.5	-	-	-	-
81	4.1	0.6	0.6	0.6	0.6	0.6	0.6	2.01	0.5	-	-	-	-					
87	4.4	0.6	0.6	0.6	0.6	0.6	0.5	1.92	0.5	-	-	-	-					





Spray angle	Ordering number		Narrowest free cross section \varnothing [in]	Air		\dot{V} water [gal/h]					Spray dimensions							
	Type	Material number		p [psi]	\dot{V}_i [SCFM]	Water column [in WC]			Aspiration height [in WC]		p air [psi]	Aspiration height [in WS]	B ₁ [in]	B ₂ [in]				
		1Y				16	6	12	18	4					8	12	24	35
		Stainless steel 316L				Stainless steel 303												
60°	136.525.xx.B2	●	●	0.02	9	0.9	-	-	-	0.5	-	-	-	-	15	12	6	9
12					1.1	-	-	-	0.6	0.6	0.5	-	-	44	12	8	12	
17					1.4	0.7	0.8	-	0.7	0.6	0.6	0.5	0.4	67	12	8	13	
20					1.5	0.8	0.8	0.8	0.7	0.7	0.6	0.6	0.5	87	12	10	16	
26					1.8	0.8	0.8	0.8	0.7	0.7	0.7	0.6	0.5	-	-	-	-	
29					1.9	0.8	0.8	0.8	0.7	0.7	0.7	0.6	0.5	-	-	-	-	
35					2.2	0.8	0.8	0.8	0.7	0.7	0.6	0.5	0.4	-	-	-	-	
38					2.3	0.7	0.8	0.8	0.7	0.6	0.6	0.5	0.4	-	-	-	-	
44					2.6	0.7	0.7	0.8	0.6	0.6	0.5	0.5	0.5	-	-	-	-	
46					2.7	0.7	0.7	0.7	0.6	0.5	0.5	0.5	0.5	-	-	-	-	
52					3.0	0.6	0.6	0.7	0.6	0.6	0.6	0.5	0.5	-	-	-	-	
55					3.1	0.6	0.6	0.7	0.6	0.6	0.6	0.5	0.5	-	-	-	-	
61					3.4	0.6	0.6	0.6	0.6	0.6	0.6	0.5	0.5	-	-	-	-	
64					3.5	0.6	0.6	0.6	0.6	0.5	0.5	0.5	0.5	-	-	-	-	
70					3.8	0.6	0.6	0.6	0.6	0.5	0.5	0.5	0.6	-	-	-	-	
73					3.9	0.6	0.6	0.6	0.6	0.5	0.5	0.6	0.6	-	-	-	-	
78	4.2	0.7	0.6	0.6	0.7	0.7	0.7	0.6	0.5	-	-	-	-					
81	4.3	0.7	0.6	0.7	0.7	0.7	0.6	0.6	0.5	-	-	-	-					
87	4.6	0.7	0.7	0.7	0.6	0.6	0.6	0.5	0.5	-	-	-	-					

Ordering Type + Material no. = Ordering no.
 example: 136.525.xx.B2 + 1Y = 136.525.1Y.B2

➤ Pneumatic atomizing nozzles, flat fan, pressure principle, external mixing Series 136.6



Features:

- Fine flat fan atomization
- Liquid pressure principle
- External mixing

Applications:

- Humidification of goods
- Cooling
- Belt humidification
- Atomization of viscous liquids

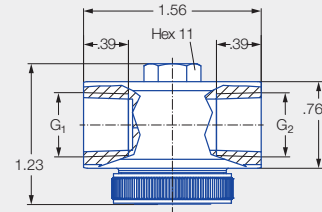

Series 136.6

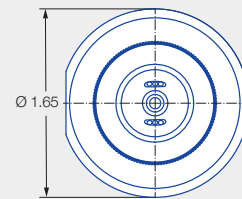
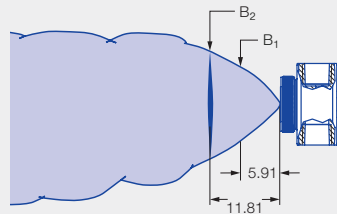

Liquid connection G ₁	Air connection G ₂	Screw plug thread (size 11)	Weight [lb] (Stainless steel 303)
1/4 NPT	1/4 NPT	5/16-24 UNF-2A	0.5

Spray angle	Ordering number		Narrowest free cross section Ø [in]	Liquid pressure p [psi]												Spray dimensions				
	Type	Material number		10			20			40			60			p air [psi]	p water [psi]	B ₁ [in]	B ₂ [in]	
		1Y		16	p air [psi]	V̇ water [gal/h]	V̇ air [SCFM]	p air [psi]	V̇ water [gal/h]	V̇ air [SCFM]	p air [psi]	V̇ water [gal/h]	V̇ air [SCFM]	p air [psi]	V̇ water [gal/h]					V̇ air [SCFM]
45°	136.616.xx.B2	●	●	0.02	12	0.4	1.5	12	0.6	1.4	12	0.9	1.5	15	1.0	1.6	20	1	3	5
					17	0.5	1.8	15	0.7	1.7	17	0.9	1.8	20	1.0	2.0	32	2	4	5
					23	0.5	2.2	20	0.7	2.1	23	0.9	2.2	26	1.0	2.4	46	3	4	5
					29	0.6	2.5	26	0.7	2.5	29	1.0	2.5	32	1.0	2.7	58	4	4	6
					35	0.5	2.9	32	0.7	2.8	35	1.0	2.9	38	1.0	3.1	73	5	4	6
					41	0.6	3.2	38	0.7	3.2	41	1.0	3.2	44	1.0	3.4	-	-	-	-
					46	0.6	3.6	44	0.7	3.5	46	1.0	3.6	49	1.0	3.8	-	-	-	-
					52	0.6	3.9	52	0.7	3.9	52	1.0	3.9	55	1.0	4.1	-	-	-	-
					58	0.6	4.3	58	0.7	4.3	58	1.0	4.3	61	1.0	4.5	-	-	-	-
					64	0.6	4.6	64	0.7	4.6	64	1.0	4.6	67	1.0	4.8	-	-	-	-
					70	0.6	5.0	70	0.7	5.0	70	1.0	4.9	73	1.0	5.2	-	-	-	-
					75	0.6	5.4	75	0.7	5.4	75	1.0	5.4	78	1.0	5.5	-	-	-	-
					81	0.6	5.7	81	0.7	5.7	81	1.0	5.7	84	1.0	5.9	-	-	-	-
					87	0.6	6.0	87	0.7	6.0	87	1.0	6.0	87	1.0	6.0	-	-	-	-





Spray angle	Ordering number				Narrowest free cross section Ø [in]	Liquid pressure p [psi]												Spray dimensions				
	Type	Material number		Stainless steel 316L		Stainless steel 303	10			20			40			60			p air [psi]	p water [psi]	B ₁ [in]	B ₂ [in]
		1Y	16				p air [psi]	V̇ water [gal/h]	V̇ _n air [SCFM]	p air [psi]	V̇ water [gal/h]	V̇ _n air [SCFM]	p air [psi]	V̇ water [gal/h]	V̇ _n air [SCFM]	p air [psi]	V̇ water [gal/h]	V̇ _n air [SCFM]				
45°	136.635.xx.B2	●	●	0.02	12	0.63	1.5	12	0.91	1.4	12	1.3	1.4	15	1.4	1.6	20	1	3	5		
					17	0.69	1.8	17	0.94	1.8	17	1.3	1.8	20	1.4	2.0	32	2	4	5		
					23	0.8	2.2	23	1.0	2.2	23	1.3	2.2	26	1.4	2.4	46	3	4	5		
					29	0.8	2.5	29	1.0	2.5	30	1.3	2.5	32	1.4	2.7	58	4	4	6		
					35	0.8	2.9	35	1.0	2.9	35	1.4	2.9	38	1.5	3.1	73	5	4	6		
					41	0.8	3.2	41	1.0	3.2	41	1.4	3.2	44	1.5	3.4	-	-	-	-		
					46	0.8	3.6	46	1.0	3.6	46	1.4	3.6	49	1.5	3.8	-	-	-	-		
					52	0.8	3.9	52	1.0	3.9	52	1.4	3.9	55	1.5	4.1	-	-	-	-		
					58	0.8	4.3	58	1.0	4.2	58	1.4	4.3	61	1.5	4.5	-	-	-	-		
					64	0.8	4.6	64	1.0	4.6	64	1.4	4.6	67	1.5	4.8	-	-	-	-		
	70	0.8	4.9	70	1.0	4.9	70	1.4	4.9	73	1.5	5.1	-	-	-	-						
	75	0.8	5.3	75	1.0	5.3	75	1.4	5.3	78	1.5	5.5	-	-	-	-						
	81	0.8	5.7	81	1.0	5.7	81	1.4	5.7	84	1.5	5.8	-	-	-	-						
	87	0.8	6.0	87	1.0	6.0	87	1.4	6.0	87	1.5	6.0	-	-	-	-						
	12	1.4	1.4	12	1.9	1.4	17	2.7	1.8	23	2.9	2.2	20	1	4	5						
	17	1.5	1.8	17	2.0	1.8	23	2.7	2.2	29	3.0	2.5	32	2	4	6						
	23	1.5	2.2	23	2.0	2.2	29	2.7	2.5	35	3.0	2.9	46	3	4	6						
	29	1.6	2.5	29	2.1	2.5	35	2.8	2.9	41	3.0	3.2	58	4	4	6						
	35	1.6	2.9	35	2.1	2.9	41	2.8	3.2	46	3.0	3.6	73	5	4	6						
	41	1.7	3.2	41	2.1	3.2	46	2.8	3.6	52	3.0	3.9	-	-	-	-						
46	1.7	3.6	46	2.1	3.6	52	2.8	3.9	58	3.0	4.2	-	-	-	-							
52	1.7	3.9	52	2.1	3.9	58	2.8	4.2	64	3.0	4.6	-	-	-	-							
58	1.7	4.2	58	2.1	4.2	64	2.8	4.6	70	3.0	4.9	-	-	-	-							
64	1.7	4.6	64	2.1	4.6	70	2.8	4.9	75	3.0	5.3	-	-	-	-							
70	1.7	4.9	70	2.1	4.9	75	2.8	5.3	81	3.0	5.7	-	-	-	-							
75	1.6	5.3	75	2.1	5.3	81	2.8	5.7	87	2.9	5.9	-	-	-	-							
81	1.6	5.7	81	2.1	5.7	87	2.7	6.0	-	-	-	-	-	-	-							
87	1.5	6.0	87	2.0	6.0	-	-	-	-	-	-	-	-	-	-							
60°	136.626.xx.B2	●	●	0.02	12	0.5	1.6	12	0.7	1.6	12	0.9	1.6	12	1.0	1.6	23	1	3	5		
					17	0.5	2.1	17	0.7	2.1	17	1.0	2.1	17	1.0	2.1	35	2	4	6		
					23	0.6	2.5	23	0.7	2.5	23	1.0	2.5	23	1.0	2.5	46	3	4	6		
					29	0.6	2.9	29	0.7	2.9	29	1.0	2.9	29	1.0	2.9	58	4	4	6		
					35	0.6	3.3	35	0.8	3.3	35	1.0	3.3	35	1.0	3.3	75	5	4	6		
					41	0.6	3.7	41	0.8	3.7	41	1.0	3.7	41	1.1	3.7	-	-	-	-		
					46	0.6	4.1	46	0.8	4.1	46	1.0	4.1	46	1.1	4.1	-	-	-	-		
					52	0.6	4.5	52	0.8	4.5	52	1.0	4.5	52	1.1	4.5	-	-	-	-		
					58	0.6	4.9	58	0.8	4.9	58	1.0	4.9	58	1.1	4.9	-	-	-	-		
					64	0.6	5.3	64	0.8	5.3	64	1.0	5.3	64	1.1	5.3	-	-	-	-		
					70	0.6	5.7	70	0.8	5.7	70	1.0	5.7	70	1.1	5.7	-	-	-	-		
					75	0.6	6.1	75	0.8	6.1	75	1.0	6.1	75	1.1	6.1	-	-	-	-		
					81	0.6	6.6	81	0.8	6.5	81	1.0	6.5	81	1.1	6.5	-	-	-	-		
					87	0.6	6.9	87	0.8	6.9	87	1.0	6.9	87	1.1	6.9	-	-	-	-		



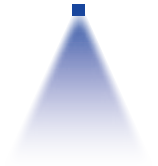

Spray angle	Ordering number		Narrowest free cross section \varnothing [in]	Liquid pressure p [psi]									Spray dimensions							
	Type	Material number		10			20			40			60			p air [psi]	p water [psi]	B ₁ [in]	B ₂ [in]	
		1Y		16	p air [psi]	V̇ water [gal/h]	V̇ _n air [SCFM]	p air [psi]	V̇ water [gal/h]	V̇ _n air [SCFM]	p air [psi]	V̇ water [gal/h]	V̇ _n air [SCFM]	p air [psi]	V̇ water [gal/h]					V̇ _n air [SCFM]
		Stainless steel 316L		Stainless steel 303																
60°	136.645.xx.B2	●	●	0.02	12	40	1.6	12	0.97	1.6	15	1.4	1.9	1.00	1.5	1.8	23	1	4	6
					17	41	2.1	17	1.02	2.1	20	1.4	2.3	1.40	1.5	2.3	35	2	4	6
					23	45	2.5	23	1.1	2.5	26	1.4	2.7	1.80	1.5	2.7	46	3	5	6
					29	47	2.9	29	1.1	2.9	32	1.4	3.1	2.20	1.5	3.1	58	4	5	6
					35	49	3.3	35	1.1	3.3	38	1.4	3.5	2.60	1.5	3.5	75	5	5	6
					41	49	3.6	41	1.1	3.7	44	1.5	3.9	3.00	1.5	3.9	-	-	-	-
					46	50	4.1	46	1.1	4.1	49	1.5	4.2	3.40	1.6	4.3	-	-	-	-
					52	50	4.5	52	1.1	4.5	55	1.5	4.7	3.80	1.6	4.7	-	-	-	-
					58	51	4.9	58	1.1	4.9	61	1.5	5.1	4.20	1.6	5.1	-	-	-	-
					64	51	5.3	64	1.1	5.3	67	1.5	5.5	4.60	1.6	5.5	-	-	-	-
					70	52	5.7	70	1.2	5.7	73	1.5	5.9	5.00	1.6	5.9	-	-	-	-
					75	52	6.1	75	1.1	6.1	78	1.5	6.3	5.40	1.6	6.3	-	-	-	-
	81	52	6.5	81	1.1	6.5	84	1.5	6.7	5.80	1.6	6.7	-	-	-	-				
	87	52	6.9	87	1.2	6.9	87	1.5	6.9	6.00	1.6	6.9	-	-	-	-				
	136.664.xx.B2	●	●	0.03	12	79	1.6	15	2.0	1.9	15	2.8	1.9	1.00	3.0	1.9	23	1	4	6
					17	86	2.1	20	2.1	2.3	20	2.8	2.3	1.40	3.0	2.3	35	2	5	6
					23	89	2.5	26	2.1	2.7	26	2.9	2.7	1.80	3.1	2.6	46	3	6	7
					29	93	2.9	32	2.2	3.1	32	2.9	3.1	2.20	3.1	3.1	58	4	6	7
					35	96	3.3	38	2.2	3.5	38	2.9	3.5	2.60	3.1	3.5	75	5	6	8
					41	98	3.7	44	2.3	3.9	44	2.9	3.9	3.00	3.1	3.9	-	-	-	-
					46	101	4.1	49	2.3	4.3	49	3.0	4.3	3.40	3.2	4.3	-	-	-	-
					52	101	4.5	55	2.3	4.7	55	3.0	4.7	3.80	3.2	4.7	-	-	-	-
					58	102	4.9	61	2.3	5.1	61	3.0	5.1	4.20	3.2	5.1	-	-	-	-
					64	103	5.3	67	2.3	5.5	67	3.0	5.5	4.60	3.2	5.5	-	-	-	-
					70	103	5.7	73	2.3	5.9	73	3.0	5.9	5.00	3.2	5.9	-	-	-	-
					75	104	6.1	78	2.3	6.3	78	3.0	6.3	5.40	3.2	6.3	-	-	-	-
	136.673.xx.B2	●	●	0.04	9	201	3.3	15	4.89	4.5	23	6.6	10.20	2.00	7.0	6.9	23	1	5	6
					15	207	4.5	20	4.89	5.5	29	6.5	11.70	6.9	7.0	7.9	35	2	5	6
					20	207	5.5	26	4.8	6.5	35	6.5	13.30	7.8	6.8	8.9	46	3	5	6
					26	205	6.5	32	4.7	7.5	41	6.2	15.10	8.9	6.5	9.8	58	4	5	6
					32	198	7.4	38	4.6	8.4	46	5.9	16.60	9.8	6.2	10.8	75	5	5	7
					38	198	8.4	44	4.4	9.4	52	5.6	18.40	10.8	5.8	11.7	-	-	-	-
					44	193	11.1	49	4.2	10.2	58	5.3	19.80	11.7	5.4	12.7	-	-	-	-
					49	187	10.2	55	4.0	11.2	64	5.0	21.50	12.7	5.1	13.6	-	-	-	-
					55	182	11.2	61	3.9	12.2	70	4.6	23.20	13.7	4.8	14.5	-	-	-	-
					61	177	12.2	67	3.7	13.1	75	4.4	24.80	14.6	4.5	15.5	-	-	-	-
67					171	13.2	73	3.5	14.1	81	4.1	26.40	15.5	4.2	16.5	-	-	-	-	
73					159	14.1	78	3.2	15.1	84	4.0	27.30	16.1	-	-	-	-	-	-	
78	151	15.1	84	3.0	16.0	87	3.9	28.00	16.5	-	-	-	-	-	-					
84	139	16.0	87	2.9	16.5	-	-	-	-	-	-	-	-	-	-					
87	130	16.5	-	-	-	-	-	-	-	-	-	-	-	-	-					





Spray angle	Ordering number		Narrowest free cross section Ø [in]	Liquid pressure p [psi]												Spray dimensions					
	Type	Material number		10			20			40			60			p air [psi]	p water [psi]	B ₁ [in]	B ₂ [in]		
		1Y		16	p air [psi]	Ṃ water [gal/h]	Ṃ _n air [SCFM]	p air [psi]	Ṃ water [gal/h]	Ṃ _n air [SCFM]	p air [psi]	Ṃ water [gal/h]	Ṃ _n air [SCFM]	p air [psi]	Ṃ water [gal/h]					Ṃ _n air [SCFM]	
		Stainless steel 316L		Stainless steel 303																	
60°	136.682.xx.B2	●	●	0,06	15	5.9	4.4	20	7.6	5.5	26	10.9	6.5	29	11.6	6.9	23	1	4	6	
					20	5.3	5.5	26	6.9	6.4	32	9.2	7.4	35	10.3	7.9	35	2	5	6	
					26	5.0	6.5	32	6.3	7.4	38	8.8	8.4	41	9.3	8.9	46	3	5	6	
					32	4.7	7.4	38	5.9	8.4	44	8.0	9.4	46	8.5	9.8	58	4	5	6	
					38	4.5	8.4	44	5.6	9.4	49	7.5	10.3	52	8.0	10.8	75	5	5	7	
					44	4.4	9.4	49	5.3	10.3	55	7.0	11.2	58	7.5	11.7	-	-	-	-	-
					49	4.2	10.3	55	5.1	11.2	61	6.7	12.2	64	7.1	12.7	-	-	-	-	-
					55	4.2	11.2	61	5.0	12.2	67	6.4	13.1	70	6.8	13.6	-	-	-	-	-
					61	4.2	12.2	67	4.9	13.1	73	6.1	14.1	75	6.4	14.6	-	-	-	-	-
					67	4.2	13.1	73	4.8	14.1	78	5.8	15.0	81	6.2	15.5	-	-	-	-	-
	73	4.0	14.1	78	4.6	14.9	84	5.6	16.0	87	5.9	16.5	-	-	-	-	-				
	78	3.7	15.0	84	4.2	16.0	87	5.5	16.5	-	-	-	-	-	-	-	-				
	84	3.2	16.0	87	3.9	16.5	-	-	-	-	-	-	-	-	-	-	-				
	87	2.9	16.5	-	-	-	-	-	-	-	-	-	-	-	-	-	-				
	136.691.xx.B2	●	●	0,10	20	13.7	8.1	29	17.8	10.3	38	24.4	12.5	38	27.0	12.5	23	1	6	8	
					26	13.2	9.6	35	17.1	11.8	44	23.2	13.9	44	25.7	13.9	35	2	6	8	
					32	12.8	11.1	41	16.4	13.2	49	22.3	15.3	49	24.4	15.4	46	3	6	8	
					38	12.5	12.5	46	16.0	14.7	55	21.3	16.8	55	23.4	16.8	58	4	6	8	
					44	12.3	13.9	52	15.3	16.1	61	20.3	18.2	61	22.5	18.2	75	5	6	8	
					49	12.0	15.4	58	14.8	17.5	67	19.7	19.7	67	21.5	19.7	-	-	-	-	
55					11.7	16.8	64	14.3	18.9	73	18.8	21.1	73	20.7	21.1	-	-	-	-		
61					11.3	18.2	70	13.8	20.4	78	18.0	22.5	78	19.6	22.5	-	-	-	-		
67					11.0	19.7	75	13.2	21.8	84	17.0	24.0	84	18.8	24.0	-	-	-	-		
73					10.5	21.1	81	12.7	23.2	87	16.7	24.7	87	18.2	24.7	-	-	-	-		
78	10.3	22.5	87	12.3	24.7	-	-	-	-	-	-	-	-	-	-						
81	10.2	23.2	-	-	-	-	-	-	-	-	-	-	-	-	-						

Ordering Type + Material no. = Ordering no.
 example: 136.682.xx.B2 + 1Y = 136.682.1Y.B2

Accessories for pneumatic atomizing nozzles

Series 136.1 to 136.6



Overview of accessories

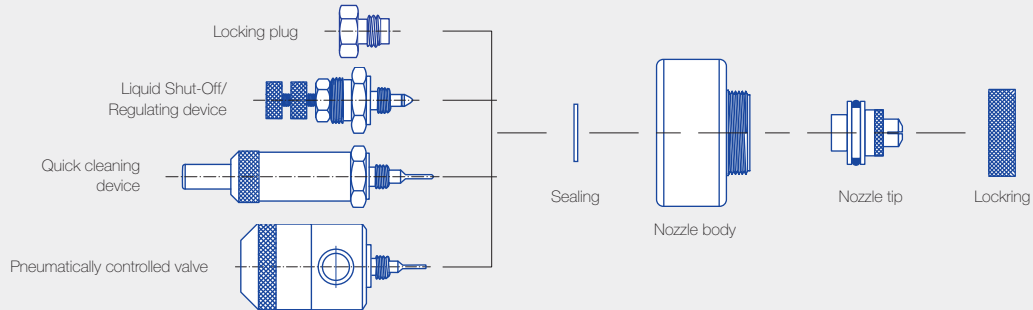

Regulating device and shut-off needle

Enables manual regulation of the flow rate and closing of the nozzle.

Material: Stainless steel 303
Weight: .07 lb

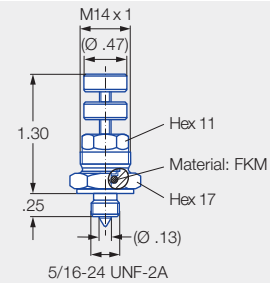

Ordering no.

Type

015.600.16

Suitable for all nozzles of series 136

Regulating device with quick-cleaning needle

Enables manual regulation of the flow rate and cleaning of the nozzle orifice.

Material: Stainless steel 303
Weight: .17 lb

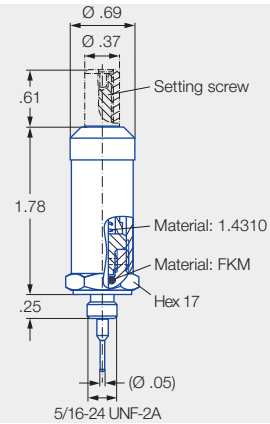

Ordering number

Type

013.601.16.30

013.602.16.30

013.603.16.30

013.604.16.30

013.605.16.30

013.606.16.30

For nozzles

136.xx1

136.xx2

136.xx3

136.xx4

136.xx5

136.xx6

Needle diameter
D
[in]

0.08

0.05

0.03

0.02

0.02

0.01



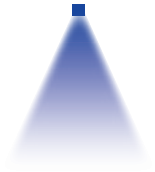

Pneumatically controlled valve. Opening pressure 30 psi, max. 180 cycles/min.

External control system via separate compressed air connection for switching the nozzle on and off.

Material: Stainless steel 303
Weight: .51 lb

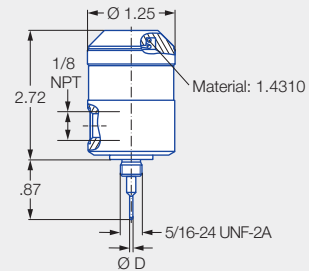

Ordering number	For nozzles	Needle diameter D [in]
013.601.16.10	136.xx1	0.08
013.602.16.10	136.xx2	0.05
013.603.16.10	136.xx3	0.03
013.604.16.10	136.xx4	0.02
013.605.16.10	136.xx5	0.02
013.606.16.10	136.xx6	0.01

- 1E for Series 136/166
- Locking plug
- 136. 000. 1Y. 00. 04
- 2A for Series 136
- Seal
- 095. 015. 7A. 03. 04
- 3A for Series 136/166
- Lockring
- 136. 000. 1Y. 00. 07

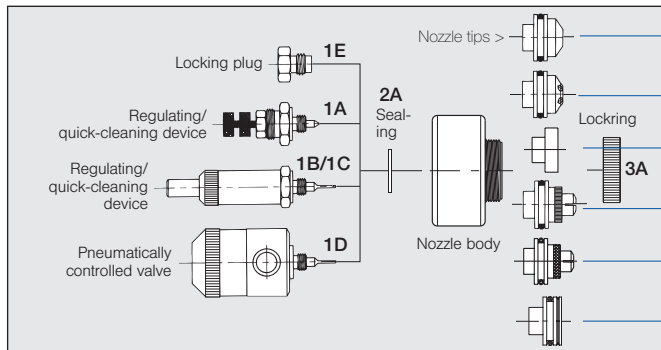

- Nozzle tips*
- Series 136.1/166.1
 - 136. xxx. 1Y. 00. 03
 - Series 136.2/166.2
 - 136. xxx. 1Y. 00. 03
 - Series 136.3/166.3
 - 136. xxx. 1Y. 00. 03
 - Series 136.4/166.4
 - 136. xxx. 1Y. 00. 03
 - Series 136.5/166.5
 - 136. xxx. 1Y. 00. 03
 - Series 136.6/166.6
 - 136. xxx. 1Y. 00. 03

* Use the 3 digits from the full nozzle assembly for the spare tip part number
Example:
136.414.17.B2

➤ Pneumatic atomizing nozzles, full cone, pressure principle, internal mixing

Series 166.1



Features:

- Version with magnetic valve
- Fine full cone atomization
- Liquid pressure principle
- Internal mixing

Applications:

- Humidification
- Cooling

Technical data:

- Operating pressure: 0–87 psi
- Voltage: 24 V DC
- Power: 8 W
- Switching frequency: Approx. 500/min
- Protective system: IP 67
- Ambient temperature: +50 °C/+122 °F
- Cable length: 39.37 in
- Material of gasket: EPDM

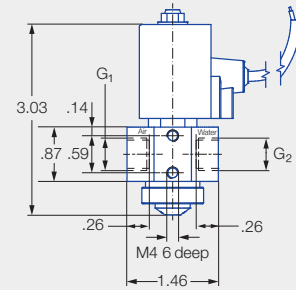

Series 166.1

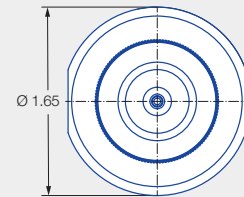
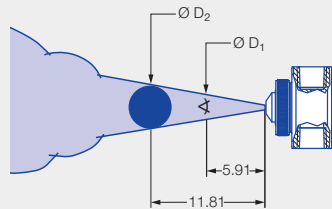

Air connection G ₁	Water connection G ₂	Weight [lb]
1/4 NPT	1/4 NPT	0.91

Spray angle	Ordering number		Narrowest free cross section Ø [in]	Liquid pressure p [psi]												Spray dimensions						
	Type	Material number		10				20				40				60						
		16		p air [psi]	V̇ water [gal/h]	V̇ air [SCFM]	p air [psi]	V̇ water [gal/h]	V̇ air [SCFM]	p air [psi]	V̇ water [gal/h]	V̇ air [SCFM]	p air [psi]	V̇ water [gal/h]	V̇ air [SCFM]	p air [psi]	p water [psi]	Ø D ₁ [in]	Ø D ₂ [in]			
20°	166.115.xx.B2	●	0.02	6	1.56	0.3	0.2	1.5	0.5	35	2.4	0.6	44	2.9	0.7	12	10	2	4			
				12	1.00	0.6	0.4	1.1	0.6	41	2.0	0.7	49	2.5	0.8	26	22	2	4			
				17	0.45	0.9	0.5	0.6	0.8	46	1.6	0.9	55	2.2	0.9	38	29	2	4			
				-	-	-	-	2.6	0.3	1.0	52	1.2	1.1	61	1.8	1.1	46	44	2	4		
				-	-	-	-	-	-	-	58	0.8	1.2	67	1.5	1.3	64	58	2	4		
				-	-	-	-	-	-	-	64	0.5	1.5	73	1.1	1.5	-	-	-	-		
				-	-	-	-	-	-	-	70	0.3	1.6	78	0.8	1.6	-	-	-	-		
				-	-	-	-	-	-	-	75	0.1	1.8	84	0.6	1.8	-	-	-	-		
				166.125.xx.B2	●	0.02	12	1.24	1.5	0.9	1.8	1.1	41	2.4	1.9	49	2.8	2.3	20	10	2	4
							17	1.16	1.9	1.1	1.7	1.3	46	2.3	2.2	55	2.7	2.5	32	22	2	4
	23	1.06	2.3				1.4	1.6	1.5	52	2.2	2.4	61	2.6	2.7	41	29	2	4			
	29	0.92	2.6				1.5	1.5	1.8	58	2.1	2.6	67	2.5	2.9	49	44	2	4			
	35	0.79	3.0				1.8	1.4	2.0	64	2.0	2.8	73	2.5	3.2	61	58	2	4			
	41	0.71	3.2				1.9	1.3	2.2	70	1.9	3.1	78	2.4	3.4	-	-	-	-			
	46	0.53	3.7				2.2	1.2	2.4	75	1.8	3.3	84	2.3	3.6	-	-	-	-			
	52	0.42	4.1				2.4	1.0	2.6	81	1.7	3.5	-	-	-	-	-	-	-			
	58	0.34	4.5				2.6	0.9	2.8	87	1.6	3.7	-	-	-	-	-	-	-			
	64	0.26	4.9				2.9	0.8	3.1	-	-	-	-	-	-	-	-	-	-			
	70	0.16	5.2	3.1	0.7	3.3	-	-	-	-	-	-	-	-	-	-						
	-	-	-	3.3	0.6	3.5	-	-	-	-	-	-	-	-	-	-	-					
-	-	-	3.5	0.5	3.7	-	-	-	-	-	-	-	-	-	-	-						





Spray angle	Ordering number		Narrowest free cross section \varnothing [in]	Liquid pressure p [psi]												Spray dimensions			
	Type	Material number		10			20			40			60			p air [psi]	p water [psi]	$\varnothing D_1$ [in]	$\varnothing D_2$ [in]
		16		p air [psi]	\dot{V} water [gal/h]	\dot{V}_i air [SCFM]	p air [psi]	\dot{V} water [gal/h]	\dot{V}_i air [SCFM]	p air [psi]	\dot{V} water [gal/h]	\dot{V}_i air [SCFM]	p air [psi]	\dot{V} water [gal/h]	\dot{V}_i air [SCFM]				
20°	166.134.xx.B2	●	0.03	17	3.5	1.6	29	5.1	2.3	44	7.5	3.1	55	8.6	1.6	26	10	2	4
				23	3.3	1.9	35	4.8	2.6	49	7.3	3.4	61	8.5	1.8	41	22	2	4
				29	3.1	2.3	41	4.6	2.9	55	7.1	3.7	67	8.3	1.9	55	29	2	4
				35	3.0	2.6	46	4.4	3.2	61	6.8	4.0	73	8.1	2.1	75	44	3	4
				41	2.9	2.9	52	4.3	3.5	67	6.6	4.3	78	7.9	2.2	87	58	3	4
				46	2.9	3.2	58	4.1	3.8	73	6.4	4.6	84	7.7	2.4	-	-	-	-
				52	2.8	3.5	64	4.0	4.1	78	6.2	4.9	-	-	-	-	-	-	-
				58	2.7	3.8	70	4.0	4.5	84	6.1	5.2	-	-	-	-	-	-	-
				64	2.7	4.1	75	3.9	4.8	-	-	-	-	-	-	-	-	-	-
				70	2.6	4.5	81	3.7	5.1	-	-	-	-	-	-	-	-	-	-
	75	2.5	4.8	87	3.6	5.4	-	-	-	-	-	-	-	-	-	-			
	81	2.4	5.1	-	-	-	-	-	-	-	-	-	-	-	-	-			
	87	2.2	5.4	-	-	-	-	-	-	-	-	-	-	-	-	-			
	166.142.xx.B2	●	0.10	20	6.4	3.0	23	14.1	2.8	46	18.7	4.7	55	24.6	2.4	12	10	2	4
				26	5.4	3.7	29	11.3	3.5	52	16.5	5.4	61	22.0	2.7	23	22	3	4
				32	5.3	4.2	35	9.3	4.2	58	14.7	6.2	67	19.9	3.0	44	29	2	4
				38	5.1	4.8	41	8.0	4.9	64	13.0	6.9	73	18.2	3.3	58	44	3	4
				44	4.6	5.5	46	7.6	5.6	70	11.8	7.6	78	16.8	3.6	87	58	3	4
				49	4.4	6.1	52	7.5	6.2	75	11.1	8.3	84	15.2	3.9	-	-	-	-
				55	4.5	6.7	58	7.2	6.8	81	10.7	8.9	-	-	-	-	-	-	-
61				4.3	7.3	64	6.8	7.4	87	10.5	9.5	-	-	-	-	-	-	-	
67				4.0	7.8	70	6.4	7.9	-	-	-	-	-	-	-	-	-	-	
73				3.7	8.4	75	5.9	8.6	-	-	-	-	-	-	-	-	-	-	
78	3.5	9.0	81	5.8	9.2	-	-	-	-	-	-	-	-	-	-				
84	3.3	9.5	87	5.7	9.8	-	-	-	-	-	-	-	-	-	-				

Ordering Type + Material no. = Ordering no.
 example: 166.134.xx.B2 + 16 = 166.134.16.B2

➤ Pneumatic atomizing nozzles, wide full cone, pressure principle, internal mixing

Series 166.2

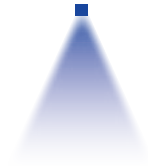

Features:

- Version with magnetic valve
- Fine full cone atomization
- Pressure principle
- Internal mixing
- Extra wide spray angle of 60°

Applications:

- Humidification of air
- Cooling

Technical data:

- Operating pressure: 0–87 psi
- Voltage: 24 V DC
- Power: 8 W
- Switching frequency: Approx. 500/min
- Protective system: IP 67
- Ambient temperature: +50 °C / +122 °F
- Cable length: 39.37 in
- Material of gasket: EPDM



Series 166.2

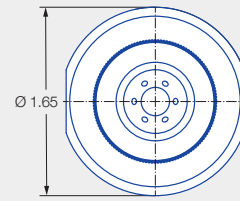
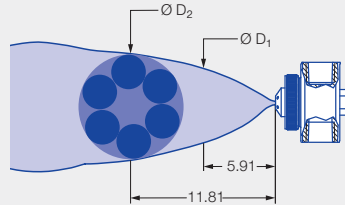
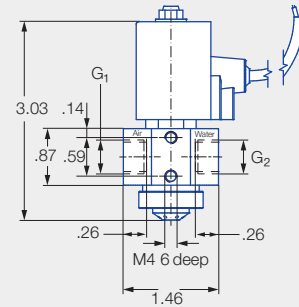

Air connection G ₁	Water connection G ₂	Weight [lb]
1/4 NPT	1/4 NPT	0.90

Spray angle	Ordering number		Narrowest free cross section Ø [in]	Liquid pressure p [psi]												Spray dimensions						
	Type	Material number		10				20				40				60				p water [psi]	Ø D ₁ [in]	Ø D ₂ [in]
		16		p air [psi]	v̇ water [gal/h]	v̇ air [SCFM]	p air [psi]	v̇ water [gal/h]	v̇ air [SCFM]	p air [psi]	v̇ water [gal/h]	v̇ air [SCFM]	p air [psi]	v̇ water [gal/h]	v̇ air [SCFM]							
60°	166.215.xx.B2	●	0.02	15	0.8	0.8	23	1.5	1.0	41	2.2	1.4	55	2.5	1.8	15	10	8	330			
				17	0.5	0.9	26	1.3	1.1	46	1.9	1.6	61	2.2	2.1	23	22	9	380			
				20	0.2	1.1	29	1.0	1.2	52	1.5	1.9	67	1.8	2.3	35	29	9	385			
				-	-	-	32	0.7	1.4	58	1.1	2.1	73	1.4	2.5	46	44	10	390			
				-	-	-	35	0.4	1.5	64	0.6	2.4	78	1.0	2.8	61	58	10	410			
				-	-	-	38	0.2	1.6	70	0.2	2.6	84	0.6	3.1	-	-	-	-			
				-	-	-	-	-	-	73	0.1	2.7	87	0.4	3.3	-	-	-	-			
				-	-	-	-	-	-	-	-	-	-	-	-	-	-	-	-			
	166.222.xx.B2	●	0.04	12	4.6	1.6	23	6.8	2.4	44	10.7	3.4	55	14.5	3.8	12	10	10	450			
				15	1.6	2.5	26	3.9	3.1	46	8.3	4.1	58	12.0	4.3	23	22	10	465			
				-	-	-	29	1.8	3.9	49	5.9	4.8	61	9.9	5.0	33	29	10	465			
				-	-	-	32	0.5	4.8	52	3.9	5.6	64	7.8	5.7	46	44	10	465			
				-	-	-	-	-	-	55	2.2	6.5	67	5.7	6.6	61	58	10	465			
				-	-	-	-	-	-	58	1.2	7.2	70	4.0	7.3	-	-	-	-			
				-	-	-	-	-	-	-	-	-	73	2.6	8.1	-	-	-	-			
				-	-	-	-	-	-	-	-	-	75	1.6	8.9	-	-	-	-			
	166.231.xx.B2	●	0.06	23	6.8	3.0	38	11.7	4.1	52	24.8	4.6	61	35.1	4.3	29	10	9	15			
				29	4.7	3.6	44	8.7	4.8	58	20.7	5.5	67	31.0	5.3	38	22	10	16			
				35	3.0	4.2	49	6.5	5.4	64	17.4	6.2	73	26.7	6.1	35	29	10	17			
				41	1.8	4.8	55	4.8	6.0	70	14.5	7.0	78	23.2	6.9	52	44	10	17			
				-	-	-	61	3.5	6.6	75	12.0	7.7	84	20.2	7.8	61	58	10	17			
				-	-	-	67	2.5	7.1	81	10.0	8.3	87	18.8	8.1	-	-	-	-			
				-	-	-	-	-	-	87	9.5	8.5	-	-	-	-	-	-	-			
				-	-	-	-	-	-	-	-	-	-	-	-	-	-	-	-			

Ordering Type + Material no. = Ordering no.
 example: 166.215.xx.B2 + 16 = 166.215.16.B2



➤ Pneumatic atomizing nozzles, flat fan, pressure principle, internal mixing Series 166.4

Features:

- Version with magnetic valve
- Fine flat fan atomization
- Liquid pressure principle
- Internal mixing

Applications:

- Belt humidification
- Cooling
- Humidification of goods

Technical data:

- Operating pressure: 0–87 psi
- Voltage: 24 V DC
- Power: 8 W
- Switching frequency: Approx. 500/min
- Protective system: IP 67
- Ambient temperature: +50 °C / +122 °F
- Cable length: 39.37 in
- Material of gasket: EPDM



Series 166.4

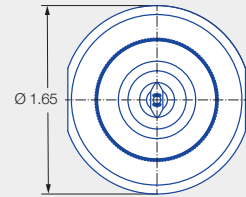
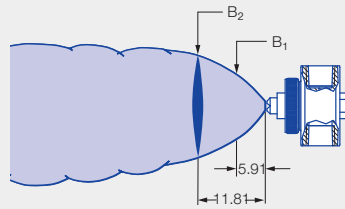
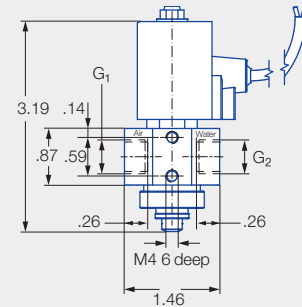

Air connection G ₁	Water connection G ₂	Weight [lb]
1/4 NPT	1/4 NPT	0.90

Spray angle	Ordering number		Narrowest free cross section Ø [in]	Liquid pressure p [psi]												Spray dimensions							
	Type	Material number		10				20				40				60				p _{air} [psi]	p _{water} [psi]	B ₁ [in]	B ₂ [in]
		16		p _{air} [psi]	V _{water} [gal/h]	V _{air} [SCFM]	p _{air} [psi]	V _{water} [gal/h]	V _{air} [SCFM]	p _{air} [psi]	V _{water} [gal/h]	V _{air} [SCFM]	p _{air} [psi]	V _{water} [gal/h]	V _{air} [SCFM]								
45°	166.414.xx.B2	●	0.03	15	2.0	0.8	20	3.8	0.9	32	5.9	1.2	44	6.6	1.5	20	10	3	5				
				17	1.6	0.9	23	3.4	0.9	38	5.3	1.4	49	6.1	1.6	35	22	4	6				
				20	1.1	1.0	26	3.1	1.1	44	4.7	1.5	55	5.5	1.8	46	29	4	6				
				23	0.7	1.1	29	2.7	1.2	49	4.1	1.8	61	5.0	2.1	55	44	5	7				
				26	0.3	1.2	32	2.4	1.3	55	3.5	2.0	67	4.5	2.2	67	58	5	8				
				–	–	–	35	2.0	1.4	61	2.9	2.2	73	3.9	2.5	–	–	–	–				
				–	–	–	38	1.6	1.5	67	2.3	2.4	78	3.4	2.7	–	–	–	–				
				–	–	–	41	1.2	1.6	73	1.7	2.6	84	2.9	2.9	–	–	–	–				
	–	–	–	44	0.8	1.8	78	1.1	2.9	87	2.6	3.1	–	–	–	–							
	–	–	–	46	0.6	1.9	84	0.7	3.1	–	–	–	–	–	–	–							
	–	–	–	49	0.3	2.0	87	0.4	3.2	–	–	–	–	–	–	–							
	166.462.xx.B2	●	0.06	17	5.0	1.5	29	5.8	1.2	44	16.3	2.4	55	20.1	2.7	17	10	5	6				
				23	3.2	2.0	35	4.8	1.4	49	13.7	2.8	58	18.6	3.0	35	22	5	7				
				29	2.5	2.4	41	3.8	1.6	55	11.8	3.4	61	17.3	3.2	46	29	5	7				
				35	1.9	2.8	46	3.0	1.9	61	10.3	3.9	64	16.2	3.5	55	44	6	8				
				41	1.5	3.2	52	2.3	2.1	67	8.8	4.4	67	15.1	3.8	87	58	6	8				
46				1.3	3.5	58	2.1	2.3	73	7.8	4.8	70	14.3	3.9	–	–	–	–					
52				1.0	3.9	64	1.6	2.5	78	6.7	5.2	73	13.6	4.2	–	–	–	–					
58				0.8	4.2	70	1.2	2.7	84	5.8	5.7	75	13.0	4.5	–	–	–	–					
64				0.6	4.6	75	0.8	2.9	87	5.4	5.8	78	12.3	4.8	–	–	–	–					
–				–	–	81	0.4	3.1	–	–	–	81	11.5	5.1	–	–	–	–					
–				–	–	84	0.2	3.2	–	–	–	84	10.9	5.2	–	–	–	–					
–				–	–	–	–	–	–	–	–	87	10.3	5.5	–	–	–	–					



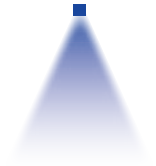

Spray angle	Ordering number		Narrowest free cross section Ø [in]	Liquid pressure p [psi]												Spray dimensions			
	Type	Material number		10			20			40			60			p air [psi]	p water [psi]	B ₁ [in]	B ₂ [in]
		16		p air [psi]	V water [gal/h]	V air [SCFM]	p air [psi]	V water [gal/h]	V air [SCFM]	p air [psi]	V water [gal/h]	V air [SCFM]	p air [psi]	V water [gal/h]	V air [SCFM]				
60°	166.425.xx.B2	●	0.02	12	1.7	0.7	20	2.5	1.0	35	3.5	1.5	35	16.1	4.3	17	10	6	8
				17	1.5	0.9	26	2.3	1.2	38	3.4	1.6	41	15.5	4.1	32	22	6	10
				23	1.2	1.1	32	2.1	1.4	44	3.2	1.8	46	15.0	4.0	44	29	7	10
				29	1.1	1.4	38	1.9	1.6	49	3.1	2.0	52	14.5	3.8	49	44	8	13
				35	0.8	1.5	44	1.7	1.8	55	2.9	2.2	58	13.9	3.7	81	58	8	13
				41	0.7	1.7	49	1.5	2.0	61	2.7	2.4	64	13.4	3.5	-	-	-	-
				44	0.6	1.8	55	1.3	2.2	67	2.6	2.5	70	12.8	3.4	-	-	-	-
				-	-	-	58	1.3	2.3	73	2.4	2.7	75	12.2	3.2	-	-	-	-
				-	-	-	64	1.1	2.5	78	2.3	2.9	81	11.7	3.1	-	-	-	-
				-	-	-	70	1.0	2.6	84	2.1	3.1	87	11.2	3.0	-	-	-	-
	-	-	-	75	0.7	2.8	87	2.1	3.2	-	-	-	-	-	-	-	-		
	-	-	-	81	0.6	3.0	-	-	-	-	-	-	-	-	-	-	-		
	-	-	-	87	0.4	3.2	-	-	-	-	-	-	-	-	-	-	-		
	-	-	-	-	-	-	-	-	-	-	-	-	-	-	-	-	-		
	-	-	-	-	-	-	-	-	-	-	-	-	-	-	-	-	-		
	166.452.xx.B2	●	0.06	15	5.0	2.3	26	8.2	3.1	46	13.2	4.5	55	18.7	4.8	15	10	5	7
				20	2.3	3.4	29	6.7	3.7	52	10.4	5.5	61	15.5	5.7	26	22	6	9
				26	2.0	4.1	32	5.3	4.2	58	8.3	6.6	67	12.8	6.6	38	29	6	10
				32	1.1	4.9	35	4.1	4.7	64	6.3	7.6	73	10.9	7.7	52	44	7	11
				38	0.3	5.8	38	3.3	5.2	70	4.7	8.5	78	8.9	8.7	73	58	7	11
41				0.03	6.1	41	2.7	5.7	75	3.5	9.4	84	7.3	9.7	-	-	-	-	
-				-	-	-	-	-	81	2.8	10.3	87	6.4	10.1	-	-	-	-	
-				-	-	-	-	-	87	2.3	11.1	-	-	-	-	-	-	-	
80°	166.433.xx.B2	●	0.02	15	3.1	1.2	26	4.8	1.6	44	8.2	2.2	55	9.9	2.6	20	10	6	8
				17	2.1	1.4	29	4.0	1.9	49	6.7	2.6	61	8.6	2.9	32	22	7	10
				20	1.4	1.6	32	3.2	2.1	55	5.4	3.0	67	7.3	3.4	44	29	8	12
				23	1.0	1.9	35	2.6	2.4	61	4.3	3.5	73	6.2	3.8	55	58	12	19
				-	-	-	38	2.0	2.5	67	3.3	3.9	78	5.1	4.2	75	58	10	16
				-	-	-	41	1.6	2.8	73	2.5	4.3	84	4.2	4.6	-	-	-	-
				-	-	-	44	1.2	2.9	78	1.7	4.7	87	3.8	4.9	-	-	-	-

Ordering Type + Material no. = Ordering no.
 example: 166.425.xx.B2 + 16 = 166.425.16.B2



Pneumatic atomizing nozzles, flat fan, pressure principle, external mixing

Series 166.6

Features:

- Version with magnetic valve
- Fine flat fan atomization
- Liquid pressure principle
- External mixing

Applications:

- Belt humidification
- Cooling
- Humidification of goods
- Atomization of viscous liquids

Technical data:

- Operating pressure: 0–8 psi
- Voltage: 24 V DC
- Power: 8 W
- Switching frequency: Approx. 500/min
- Protective system: IP 67
- Ambient temperature: +50 °C / +122 °F
- Cable length: 39.37 in
- Material of gasket: EPDM



Series 166.6

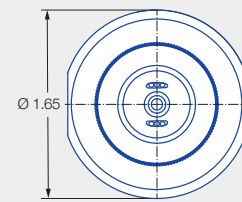
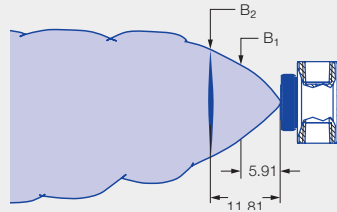
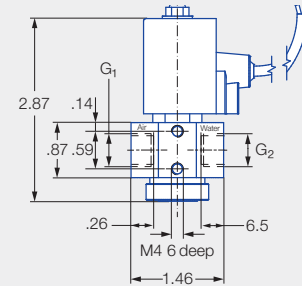

Air connection G ₁	Water connection G ₂	Weight [lb]
1/4 NPT	1/4 NPT	0.90

Spray angle	Ordering number		Narrowest free cross section Ø [in]	Liquid pressure p [psi]												Spray dimensions							
	Type	Material number		10				20				0.30				0.35				p _{air} [psi]	p _{water} [bar]	B ₁ [in]	B ₂ [mm]
		16		p _{air} [psi]	V _{water} [gal/h]	V _{air} [SCFM]	p _{air} [psi]	V _{water} [gal/h]	V _{air} [SCFM]	p _{air} [psi]	V _{water} [gal/h]	V _{air} [SCFM]	p _{air} [psi]	V _{water} [gal/h]	V _{air} [SCFM]								
45°	166.616.xx.B2	●	0.02	12	0.4	1.5	12	0.6	1.4	12	0.9	1.5	15	1.0	1.6	20	1	3	5				
				17	0.5	1.8	15	0.6	1.7	17	0.9	1.8	20	1.0	2.0	32	2	4	5				
				23	0.5	2.2	20	0.7	2.1	23	0.9	2.2	26	1.0	2.4	46	3	4	5				
				29	0.6	2.5	26	0.7	2.5	29	1.0	2.5	32	1.0	2.7	58	4	4	6				
				35	0.5	2.9	32	0.7	2.8	35	1.0	2.9	38	1.0	3.1	73	5	4	6				
				41	0.6	3.2	38	0.7	3.2	41	1.0	3.2	44	1.0	3.4	-	-	-	-				
				46	0.6	3.6	44	0.7	3.5	46	1.0	3.6	49	1.0	3.8	-	-	-	-				
				52	0.6	3.9	52	0.7	3.9	52	1.0	3.9	55	1.0	4.1	-	-	-	-				
				58	0.6	4.3	58	0.7	4.3	58	1.0	4.3	61	1.0	4.5	-	-	-	-				
				64	0.6	4.6	64	0.7	4.6	64	1.0	4.6	67	1.0	4.8	-	-	-	-				
				70	0.6	5.0	70	0.7	5.0	70	1.0	4.9	73	1.0	5.2	-	-	-	-				
				75	0.6	5.4	75	0.7	5.4	75	1.0	5.4	78	1.0	5.5	-	-	-	-				
				81	0.6	5.7	81	0.7	5.7	81	1.0	5.7	84	1.0	5.9	-	-	-	-				
				87	0.6	6.0	87	0.7	6.0	87	1.0	6.0	87	1.0	6.0	-	-	-	-				
				45°	166.654.xx.B2	●	0.03	12	1.4	1.4	12	1.9	1.4	17	2.7	1.8	23	2.9	2.2	20	1	3	5
								17	1.5	1.8	17	2.0	1.8	23	2.7	2.2	29	3.0	2.5	32	2	4	5
								23	1.5	2.2	23	2.0	2.2	29	2.7	2.5	35	3.0	2.9	46	3	4	5
								29	1.6	2.5	29	2.1	2.5	35	2.8	2.9	41	3.0	3.2	58	4	4	6
35	1.6	2.9	35					2.1	2.9	41	2.8	3.2	46	3.0	3.6	73	5	4	6				
41	1.7	3.2	41					2.1	3.2	46	2.8	3.6	52	3.0	3.9	-	-	-	-				
46	1.7	3.6	46					2.1	3.6	52	2.8	3.9	58	3.0	4.2	-	-	-	-				
52	1.7	3.9	52					2.1	3.9	58	2.8	4.2	64	3.0	4.6	-	-	-	-				
58	1.7	4.2	58					2.1	4.2	64	2.8	4.6	70	3.0	4.9	-	-	-	-				
64	1.7	4.6	64					2.1	4.6	70	2.8	4.9	75	3.0	5.3	-	-	-	-				
70	1.7	4.9	70					2.1	4.9	75	2.8	5.3	81	3.0	5.7	-	-	-	-				
75	1.6	5.3	75					2.1	5.3	81	2.8	5.7	87	2.9	5.9	-	-	-	-				
81	1.6	5.7	81	2.1	5.7	87	2.7	6.0	-	-	-	-	-	-	-								
87	1.5	6.0	87	2.0	6.0	-	-	-	-	-	-	-	-	-	-								





Spray angle	Ordering number		Narrowest free cross section \varnothing [in]	Liquid pressure p [psi]												Spray dimensions				
	Type	Material number		10			20			0.30			0.35			p air [psi]	p water [bar]	B ₁ [in]	B ₂ [mm]	
		16		p air [psi]	V water [gal/h]	V _i air [SCFM]	p air [psi]	V water [gal/h]	V _i air [SCFM]	p air [psi]	V water [gal/h]	V _i air [SCFM]	p air [psi]	V water [gal/h]	V _i air [SCFM]					
60°	166.626.xx.B2	●	0.02	12	0.5	1.6	12	0.7	1.6	12	0.9	1.6	0.80	12	1.6	23	1	3	5	
				17	0.5	2.1	17	0.7	2.1	17	1.0	2.1	1.20	17	2.1	35	2	4	6	
				23	0.6	2.5	23	0.7	2.5	23	1.0	2.5	1.60	23	2.5	46	3	4	6	
				29	0.6	2.9	29	0.7	2.9	29	1.0	2.9	2.00	29	2.9	58	4	4	6	
				35	0.6	3.3	35	0.8	3.3	35	1.0	3.3	2.40	35	3.3	75	5	4	6	
				41	0.6	3.7	41	0.8	3.7	41	1.0	3.7	2.80	41	3.7	-	-	-	-	
				46	0.6	4.1	46	0.8	4.1	46	1.0	4.1	3.20	46	4.1	-	-	-	-	
				52	0.6	4.5	52	0.8	4.5	52	1.0	4.5	3.60	52	4.5	-	-	-	-	
				58	0.6	4.9	58	0.8	4.9	58	1.0	4.9	4.00	58	4.9	-	-	-	-	
				64	0.6	5.3	64	0.8	5.3	64	1.0	5.3	4.40	64	5.3	-	-	-	-	
				70	0.6	5.7	70	0.8	5.7	70	1.0	5.7	4.80	70	5.7	-	-	-	-	
				75	0.6	6.1	75	0.8	6.1	75	1.0	6.1	5.20	75	6.1	-	-	-	-	
	81	0.6	6.6	81	0.8	6.5	81	1.0	6.5	5.60	81	6.5	-	-	-	-				
	87	0.6	6.9	87	0.8	6.9	87	1.0	6.9	6.00	87	6.9	-	-	-	-				
		166.682.xx.B2	●	0.06	15	5.9	4.4	20	7.6	5.5	26	10.9	6.5	2.00	29	6.9	23	1	4	6
	20				5.3	5.5	26	6.9	6.4	32	9.2	7.4	2.40	35	7.9	35	2	5	6	
	26				5.0	6.5	32	6.3	7.4	38	8.8	8.4	2.80	41	8.9	46	3	5	6	
	32				4.7	7.4	38	5.9	8.4	44	8.0	9.4	3.20	46	9.8	58	4	5	6	
	38				4.5	8.4	44	5.6	9.4	49	7.5	10.3	3.60	52	10.8	75	5	5	7	
	44				4.4	9.4	49	5.3	10.3	55	7.0	11.2	4.00	58	11.7	-	-	-	-	
	49				4.2	10.3	55	5.1	11.2	61	6.7	12.2	4.40	64	12.7	-	-	-	-	
	55				4.2	11.2	61	5.0	12.2	67	6.4	13.1	4.80	70	13.6	-	-	-	-	
	61				4.2	12.2	67	4.9	13.1	73	6.1	14.1	5.20	75	14.6	-	-	-	-	
	67				4.2	13.1	73	4.8	14.1	78	5.8	15.0	5.60	81	15.5	-	-	-	-	
	73				4.0	14.1	78	4.6	14.9	84	5.6	16.0	6.00	87	16.5	-	-	-	-	
	78				3.7	15.0	84	4.2	16.0	87	5.5	16.5	-	-	-	-	-	-	-	
	84	3.2	16.0	87	3.9	16.5	-	-	-	-	-	-	-	-	-	-				
	87	2.9	16.5	-	-	-	-	-	-	-	-	-	-	-	-	-				
		166.691.xx.B2	●	0.10	20	13.7	8.1	29	17.8	10.3	38	24.4	12.5	2.60	38	12.5	23	1	6	8
	26				13.2	9.6	35	17.1	11.8	44	23.2	13.9	3.00	44	13.9	35	2	6	8	
	32				12.8	11.1	41	16.4	13.2	49	22.3	15.3	3.40	49	15.4	46	3	6	8	
	38				12.5	12.5	46	16.0	14.7	55	21.3	16.8	3.80	55	16.8	58	4	6	8	
	44				12.3	13.9	52	15.3	16.1	61	20.3	18.2	4.20	61	18.2	75	5	6	8	
	49				12.0	15.4	58	14.8	17.5	67	19.7	19.7	4.60	67	19.7	-	-	-	-	
	55				11.7	16.8	64	14.3	18.9	73	18.8	21.1	5.00	73	21.1	-	-	-	-	
	61				11.3	18.2	70	13.8	20.4	78	18.0	22.5	5.40	78	22.5	-	-	-	-	
67	11.0				19.7	75	13.2	21.8	84	17.0	24.0	5.80	84	24.0	-	-	-	-		
73	10.5				21.1	81	12.7	23.2	87	16.7	24.7	6.00	87	24.7	-	-	-	-		
78	10.3				22.5	87	12.3	24.7	-	-	-	-	-	-	-	-	-	-		
81	10.2				23.2	-	-	-	-	-	-	-	-	-	-	-	-	-		

Ordering Type + Material no. = Ordering no.
 example: 166.626.xx.B2 + 16 = 166.626.16.B2



➤ Pneumatic atomizing nozzles, full cone, siphon principle, internal mixing Series 140

Features:

- Particularly fine full cone atomization
- Siphon principle
- Internal mixing
- Integrated regulating device
- Material: Brass

Applications:

- Lubrication
- Cooling
- Humidification



Series 140

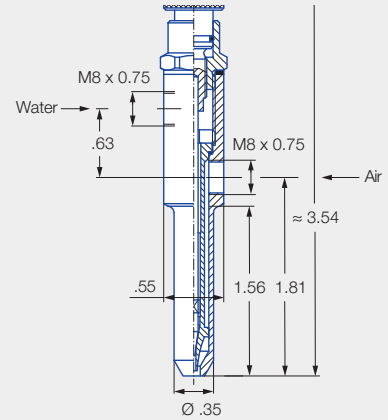

Material	Weight [lb]
Brass	0.07

Spray angle	Ordering number	Narrowest free cross section Ø [in]		Hs Aspiration height [in WS]	Flow rate							
		Water	Air		7		15		30		45	
					\dot{V}_W [gal/h]	\dot{V}_A L [SCFM]	\dot{V}_W [gal/h]	\dot{V}_A L [SCFM]	\dot{V}_W [gal/h]	\dot{V}_A L [SCFM]	\dot{V}_W [gal/h]	\dot{V}_A L [SCFM]
20°-30°	140.252.30.01	0.02	0.03	20	-	-	1.2	2.4	2.1	3.5	2.8	4.7
		0.02	0.03	8	1.2	1.50	1.8	2.4	2.6	3.5	3.2	4.7

Assembly scheme/Accessories

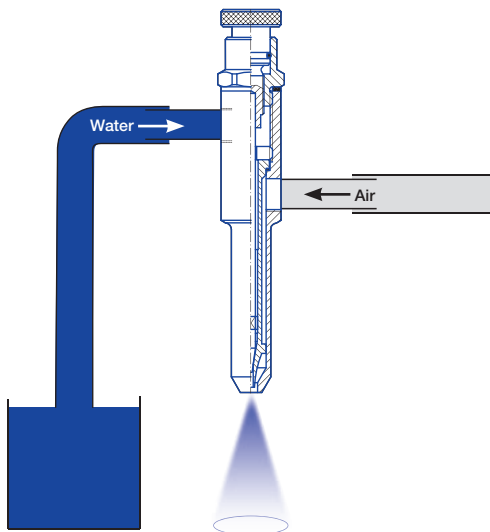

Accessories:

- Gasket
014.040.72
7.8 x 12 x 1 (EWP 210)



- Nipple
014.010.30.04
(Material: Brass)
Weight: .04 lb

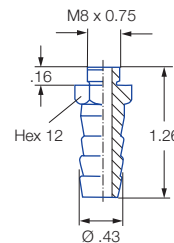

➤ Pneumatic atomizing nozzles for atomizing viscous media

Series 176 ViscoMist



The ViscoMist™ series offers independent regulation of both atomizing air and fan air, which provides the user with infinite control over the viscous fluid's spray pattern and roplet size.

The ViscoMist™ nozzle features a standard 'Liquid Shut-Off/Clean-Out Needle' function. This design element activates and deactivates the liquid supply, while simultaneously removing excess fluid from the fluid nozzle preventing clogging. This feature is especially vital when the viscous liquids are being applied in continuous process environments.

The modular design of the ViscoMist™ allows maximum flexibility to meet the exact spray requirements.

Interchangeable air caps and various flow capacities are available to suit any spraying application needs.



Series 176 ViscoMist

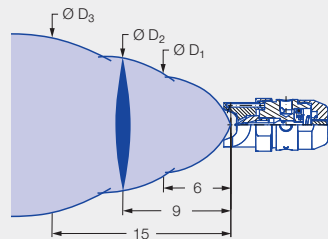
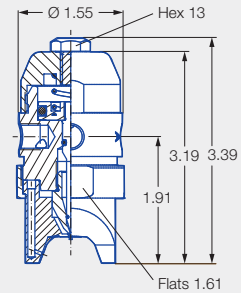

External mixing nozzle for viscous liquids, e.g. for:

- Coating processes
- Moisturising
- Lubrication
- Glazing
- Disinfection

One nozzle – several spray characters:

- Spray characters
 - Solid stream
 - Full cone
 - Flat fan
- Independent regulation of liquid, atomizing air and fan air
- Fluid circulation possible (nozzle body with five connections)

Nozzle sizes:

- Ø 0.01 in to 0.10 in

Valve position:

- Normally closed, fail-safe with loss of air

Signal air pressure:

- Min. 30 psi, max. 45 psi

Cycles per minute:

- 180 cycles/min (short term)

Connection thread:

- 1/8 NPT
- BSPP thread available on request

Weight:

- 1.21 lb

Material:

- 1Y (stainless steel 316L)

Flow rate range:

- Water: .55 to 21.4 gal/hr, at 30 psi
- Air 27.5 to 104.12 gal/min in normal condition, at 30 psi

Atomizing air/Signal air/Fan air:

The atomizing air causes the liquid to atomize at the nozzle orifice. The spray character can be adjusted with the fan air to suit the application. The signal air activates the nozzle.

Nozzle body configurations

Nozzle body configuration 2

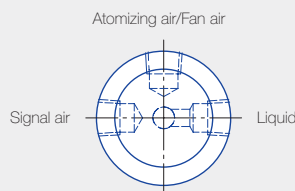

Version with three connections

Nozzle body configuration 4

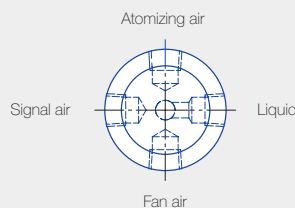

Version with four connections

Nozzle body configuration 5

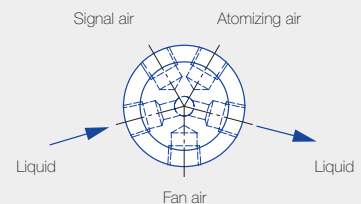

Version with five connections



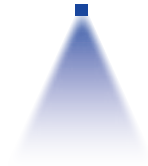

Ordering number	Narrowest free cross section Ø [in]	Liquid		Air			Spray dimensions [in] at distance D ₁ , D ₂ and D ₃																
		Liquid pressure p [psi]	V̇ water [gal/h]	Air pressure p air [psi]	Atomizing air [SCFM]	Fan air [SCFM]	Atomizing air [psi]	Liquid pressure p [psi]	Fan air [psi]														
									0.00*			5			10			15			22		
									Ø D ₁ = 6 in	Ø D ₂ = 9 in	Ø D ₃ = 15 in	Ø D ₁ = 6 in	Ø D ₂ = 9 in	Ø D ₃ = 15 in	Ø D ₁ = 6 in	Ø D ₂ = 9 in	Ø D ₃ = 15 in	Ø D ₁ = 6 in	Ø D ₂ = 9 in	Ø D ₃ = 15 in	Ø D ₁ = 6 in	Ø D ₂ = 9 in	Ø D ₃ = 15 in
176.201.1Y.01.00 176.401.1Y.01.00 176.501.1Y.01.00	0.01	2	0.5	2	0.2	0.6	4	5	2	2	4	6	7	8	7	9	11	7	9	10	7	9	11
		4	0.7	4	0.4	0.8		10	2	2	3	6	8	11	8	11	13	9	12	13	9	11	13
		10	1.2	10	0.6	1.3		15	-	-	-	7	8	11	8	12	15	9	12	14	10	12	15
		15	1.5	15	0.7	1.7		22	-	-	-	7	8	14	8	10	13	10	12	14	11	13	15
		20	1.7	20	0.8	2.0	15	5	2	2	4	4	5	7	5	7	9	6	9	11	7	9	12
		25	1.9	25	0.9	2.3		10	2	2	4	3	4	7	5	7	9	6	8	9	7	9	11
		29	2.1	29	1.1	2.7		15	1	2	3	3	5	7	5	7	10	6	9	11	7	9	13
		35	2.3	35	1.2	3.0		22	-	-	-	4	6	8	6	7	10	7	10	14	7	11	14
		40	2.4	40	1.4	3.3	30	5	2	2	4	2	3	4	4	5	6	4	6	7	6	8	9
		46	2.6	46	1.5	3.7		10	2	2	4	2	4	6	3	4	6	4	7	9	6	8	10
		51	2.7	51	1.6	4.0		15	2	2	4	3	4	6	4	5	7	5	8	10	6	8	10
		58	3.0	58	1.8	4.5		22	-	-	-	2	3	5	4	6	7	6	7	9	7	9	12
		176.202.1Y.01.00 176.402.1Y.01.00 176.502.1Y.01.00	0.02	2	1.1	2	0.3	0.6	4	5	2	2	4	6	7	11	2	10	12	7	9	11	8
4	1.6			4	0.4	0.8	10	-		-	-	7	9	10	3	12	14	11	13	16	12	13	16
10	2.4			10	0.6	1.3	15	-		-	-	6	8	9	3	11	17	12	13	18	12	15	22
15	3.0			15	0.7	1.7	22	-		-	-	-	-	-	3	11	14	11	13	17	14	16	19
20	3.5			20	0.8	2.0	15	5	2	2	4	4	6	6	5	7	9	6	7	9	7	9	10
25	4.0			25	0.9	2.3		10	2	2	4	4	5	7	6	7	9	7	9	10	8	9	11
29	4.3			29	1.1	2.7		15	-	-	-	4	6	8	7	8	11	7	9	13	8	10	13
35	4.7			35	1.2	3.0		22	-	-	-	-	-	-	7	8	12	8	10	14	10	12	15
40	5.1			40	1.4	3.3	30	5	2	2	3	2	3	4	4	5	7	4	6	7	5	8	9
46	5.4			46	1.5	3.7		10	2	2	3	3	4	5	4	6	7	6	7	7	6	8	10
51	5.7			51	1.6	4.0		15	1	2	4	3	4	5	4	6	7	5	7	9	6	8	10
58	6.2			58	1.8	4.5		22	-	-	-	3	4	6	4	6	9	5	7	9	7	9	12
176.203.1Y.01.00 176.403.1Y.01.00 176.503.1Y.01.00	0.03			2	2.2	2	0.2	0.6	4	5	-	-	-	9	12	16	13	16	19	13	16	20	12
		4	3.3	4	0.2	0.8	6	-		-	-	9	11	13	12	14	20	16	19	24	17	23	29
		10	5.1	10	0.4	1.3	10	-		-	-	-	-	-	13	16	21	16	18	25	18	21	28
		15	6.3	15	0.5	1.7	13	-		-	-	-	-	-	11	14	18	15	18	24	16	20	23
		20	7.3	20	0.6	2.3	16	5	2	2	4	6	8	11	7	9	11	9	12	15	11	14	16
		25	8.2	25	0.6	3.0		10	-	-	-	6	8	10	9	12	15	12	14	18	13	15	17
								15	-	-	-	-	-	-	9	11	16	12	15	20	12	16	19
								22	-	-	-	-	-	-	9	11	15	11	15	20	13	17	21

Notice:

The fourth digit in the order number (2, 4 or 5) stands for the housing variant (for details see Page 139).

* A cone-shaped spray pattern is produced without fan air.





Ordering number	Narrowest free cross section Ø [in]	Liquid		Air			Spray dimensions [in] at distance D ₁ , D ₂ and D ₃																
		Liquid pressure p [psi]	V̇ water [gal/h]	Air pressure p air [psi]	Atomizing air [SCFM]	Fan air [SCFM]	Atomizing air [psi]	Liquid pressure p [psi]	Fan air [psi]														
									0.00*			5			10			15			22		
									Ø D ₁ = 6 in	Ø D ₂ = 9 in	Ø D ₃ = 15 in	Ø D ₁ = 6 in	Ø D ₂ = 9 in	Ø D ₃ = 15 in	Ø D ₁ = 6 in	Ø D ₂ = 9 in	Ø D ₃ = 15 in	Ø D ₁ = 6 in	Ø D ₂ = 9 in	Ø D ₃ = 15 in	Ø D ₁ = 6 in	Ø D ₂ = 9 in	Ø D ₃ = 15 in
176.203.1Y.01.00 176.403.1Y.01.00 176.503.1Y.01.00	0.03	29	9.0	29	1.3	2.7	30	5	1	2	3	4	6	7	6	8	9	7	9	12	8	9	11
		35	9.7	35	1.4	3.0		10	-	-	-	5	6	8	7	9	13	9	12	15	10	12	14
		40	10.4	40	1.6	3.3		15	-	-	-	5	7	8	7	9	13	9	12	16	10	13	16
		46	11.1	40	1.7	3.7		22	-	-	-	-	-	-	7	9	13	9	12	17	10	13	17
		51	11.7	46	1.9	4.0	40	5	2	2	4	4	5	7	6	7	9	7	8	11	7	9	12
		58	12.7	51	2.1	4.5		10	-	-	-	4	6	8	6	8	10	7	9	12	9	11	15
					15	-		-	-	-	-	-	7	9	12	8	10	14	9	11	15		
							22	-	-	-	-	-	-	7	9	13	9	11	15	9	11	16	
176.204.1Y.01.00 176.404.1Y.01.00 176.504.1Y.01.00	0.04	2	4.5	2	1.4	1.2	4	5	-	-	-	6	8	12	12	16	18	13	16	22	12	16	20
		4	6.4	4	2.0	1.7		10	-	-	-	-	-	-	12	15	41	14	17	21	16	19	25
		10	9.8	10	3.3	2.7		15	-	-	-	-	-	-	10	15	20	14	18	23	16	20	27
		15	12.1	15	4.3	3.4	15	5	2	2	3	4	6	7	6	8	10	8	10	13	10	12	17
		20	14.0	20	5.2	4.1		10	-	-	-	4	6	9	7	8	11	9	11	15	10	13	17
		25	15.6	25	6.0	4.7		15	-	-	-	4	5	7	6	7	12	9	10	15	10	12	19
		29	17.2	29	6.8	5.3		22	-	-	-	-	-	-	6	8	11	8	10	16	9	12	18
		35	18.6	35	7.6	6.0	30	5	2	2	4	3	4	6	4	5	7	4	7	9	6	7	11
		40	19.9	40	8.4	6.6		10	-	-	-	3	4	6	4	5	8	5	7	9	6	8	11
		46	21.2	46	9.2	7.2		15	-	-	-	3	4	6	4	6	8	5	7	10	6	8	11
		51	22.4	51	10.1	7.8		22	-	-	-	3	4	6	4	6	9	5	7	10	6	8	12
		58	24.2	58	11.5	8.9	40	5	2	3	4	3	4	6	4	5	7	4	6	8	6	7	10
								10	2	3	4	2	4	6	4	5	7	4	6	9	6	7	10
								15	-	-	-	3	4	6	4	5	7	4	6	10	6	7	11
					22	-		-	-	3	4	6	4	5	7	4	6	9	6	7	12		
176.205.1Y.01.00 176.405.1Y.01.00 176.505.1Y.01.00	0.05	2	6.5	2	1.3	1.2	4	5	-	-	-	9	13	18	14	18	21	16	21	25	18	21	26
		4	9.3	4	1.9	1.7		10	-	-	-	-	-	-	13	18	23	16	20	26	16	19	24
		10	14.3	10	3.0	2.7		15	-	-	-	-	-	-	13	16	19	14	18	22	17	22	29
		15	17.6	15	4.0	3.4	15	5	-	-	-	5	7	9	7	9	15	9	11	17	7	14	20
		20	20.2	20	4.7	4.1		10	-	-	-	4	7	9	7	9	13	9	11	16	7	14	20
		25	22.8	25	5.4	4.7		15	-	-	-	-	-	-	7	9	14	9	12	17	11	13	19
		29	25.0	29	6.1	5.3		22	-	-	-	-	-	-	7	9	12	9	12	16	10	13	19
		35	27.2	35	6.8	6.0	30	5	2	2	4	3	4	6	4	6	8	6	7	10	7	9	13
		40	29.2	40	7.5	6.6		10	-	-	-	3	4	6	4	6	9	5	7	11	7	9	14
		46	31.0	46	8.2	7.2		15	-	-	-	3	4	6	4	6	9	6	7	11	7	9	14
		51	32.8	51	8.9	7.8		22	-	-	-	3	4	6	4	6	8	6	7	12	7	9	14
		58	35.4	58	10.1	8.9	40	5	2	2	4	3	4	6	4	5	8	4	6	9	6	7	11
								10	-	-	-	2	4	6	4	5	8	4	7	10	6	8	12
								15	-	-	-	2	4	5	4	5	8	5	7	9	6	8	12
					22	-		-	-	2	4	6	4	5	8	4	7	10	6	8	12		

Notice:

The fourth digit in the order number (2, 4 or 5) stands for the housing variant (for details see Page 139).

* A cone-shaped spray pattern is produced without fan air.





Ordering number	Narrowest free cross section Ø [in]	Liquid		Air			Spray dimensions [in] at distance D ₁ , D ₂ and D ₃																											
		Liquid pressure p [psi]	V water [gal/h]	Air pressure p air [psi]	Atomizing air [SCFM]	Fan air [SCFM]	Atomizing air [psi]	Liquid pressure p [psi]	Fan air [psi]																									
									10			15			20			25			30													
									Ø D ₁ = 6 in	Ø D ₂ = 9 in	Ø D ₃ = 15 in	Ø D ₁ = 6 in	Ø D ₂ = 9 in	Ø D ₃ = 15 in	Ø D ₁ = 6 in	Ø D ₂ = 9 in	Ø D ₃ = 15 in	Ø D ₁ = 6 in	Ø D ₂ = 9 in	Ø D ₃ = 15 in	Ø D ₁ = 6 in	Ø D ₂ = 9 in	Ø D ₃ = 15 in											
176.206.1Y.01.00 176.406.1Y.01.00 176.506.1Y.01.00	0.04	2	11.0	2	0.9	1.2	15	5	9	13	20	11	16	24	14	18	26	-	-	-	-	-	-											
		4	15.7	4	1.3	1.7		10	9	14	21	13	17	26	14	20	30	-	-	-	-	-	-											
		10	24.0	10	2.0	2.7		15	10	14	20	12	17	24	14	20	27	-	-	-	-	-	-											
		15	29.5	15	2.6	3.4		22	-	-	-	12	15	22	13	18	24	-	-	-	-	-	-											
		20	34.1	20	3.0	4.1	30	5	6	9	13	8	11	16	9	12	18	9	13	18	10	13	17											
								10	7	9	12	8	10	15	9	12	18	10	14	19	11	14	20											
								15	6	9	13	7	10	15	9	12	17	10	13	19	11	14	21											
								22	-	-	-	7	10	14	9	11	17	10	13	20	11	14	20											
								25	38.1	25	3.5	4.7	40	5	6	7	11	7	9	12	7	10	14	8	11	16	8	11	17					
														10	6	8	12	7	9	13	7	10	15	8	11	16	9	12	16					
														15	6	7	11	7	9	13	7	9	15	8	11	16	9	12	17					
														22	5	7	10	6	8	13	7	10	15	8	11	17	9	13	19					
		29	41.7	29	3.9	5.3	60	5	5	7	10	6	8	12	7	9	13	7	9	14	7	9	14											
								10	5	7	11	6	8	12	7	9	13	7	9	14	7	10	15											
15	5							7	11	6	8	12	6	8	12	7	10	14	8	10	16													
22	-							-	-	6	8	12	6	9	14	7	10	15	8	11	17													
176.207.1Y.01.00 176.407.1Y.01.00 176.507.1Y.01.00	0.08	2	15.6	2	2.1	2.0	15	5	8	11	16	11	14	19	13	17	21	13	19	27	16	19	26											
		4	22.4	4	3.2	2.9		10	8	11	16	11	14	19	12	16	23	14	18	28	16	21	30											
		10	34.3	10	5.0	4.6		15	6	9	14	9	12	18	11	14	21	12	17	24	14	20	29											
		15	42.1	15	6.4	5.9		22	-	-	-	-	-	-	-	-	-	-	-	-	-	-	-	-										
		20	48.8	20	7.6	7.2	30	5	4	6	9	6	7	11	7	9	14	9	11	15	10	13	19											
								10	4	6	9	6	7	11	7	10	15	8	11	16	10	13	19											
								15	4	6	10	5	7	11	7	9	13	8	11	16	9	12	19											
								22	-	-	-	-	-	-	6	9	13	7	10	15	9	12	17											
		25	54.6	25	8.8	8.3	45	5	4	5	7	4	7	10	6	8	12	7	9	13	8	11	15											
								10	4	5	8	5	7	10	6	8	12	7	9	14	8	11	16											
								15	4	4	7	5	6	10	6	7	12	7	9	13	8	11	15											
								22	4	5	8	4	6	10	6	8	12	6	9	14	8	11	15											
		29	59.9	29	10.0	9.4	60	5	4	4	6	4	6	9	6	7	10	6	9	14	7	10	16											
								10	4	4	7	4	6	9	5	7	11	6	8	13	7	10	14											
15	3							4	7	4	6	9	5	7	11	6	9	13	7	10	15													
22	-							-	-	4	6	9	5	7	10	6	8	13	7	9	14													

Notice:

The fourth digit in the order number (2, 4 or 5) stands for the housing variant (for details see Page 139).

* A cone-shaped spray pattern is produced without fan air.



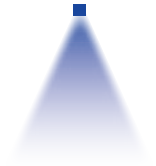

Ordering number	Narrowest free cross section Ø [in]	Liquid		Air			Spray dimensions [in] at distance D ₁ , D ₂ and D ₃																		
		Liquid pressure p [psi]	V water [gal/h]	Air pressure p air [psi]	Atomizing air [SCFM]	Fan air [SCFM]	Atomizing air [psi]	Liquid pressure p [psi]	Fan air [psi]																
									10			15			20			25			30				
									Ø D ₁ = 6 in	Ø D ₂ = 9 in	Ø D ₃ = 15 in	Ø D ₁ = 6 in	Ø D ₂ = 9 in	Ø D ₃ = 15 in	Ø D ₁ = 6 in	Ø D ₂ = 9 in	Ø D ₃ = 15 in	Ø D ₁ = 6 in	Ø D ₂ = 9 in	Ø D ₃ = 15 in	Ø D ₁ = 6 in	Ø D ₂ = 9 in	Ø D ₃ = 15 in		
176.208.1Y.01.00 176.408.1Y.01.00 176.508.1Y.01.00	0.09	2	25.7	2	2.3	2.6	15	5	7	11	17	11	14	24	12	18	28	-	-	-	-	-	-		
		4	30.3	4	2.7	3.1		10	7	11	17	10	14	24	13	19	30	-	-	-	-	-	-		
		10	43.1	10	4.0	4.6		15	-	-	-	9	13	22	12	17	27	-	-	-	-	-	-		
		15	52.6	15	5.1	5.9		22	-	-	-	10	14	21	12	15	23	-	-	-	-	-	-		
		20	60.7	20	6.0	7.2	30	5	4	7	12	7	10	14	8	11	16	9	13	18	11	18	22		
		25	67.7	25	7.0	8.3		10	4	7	10	7	9	14	9	11	16	9	14	20	11	15	21		
		29	74.2	29	7.9	9.4		15	4	7	9	6	8	13	7	10	16	9	12	19	11	15	24		
		35	80.1	35	8.8	10.4		22	-	-	-	6	8	13	8	11	15	9	12	18	11	15	22		
		40	85.6	40	9.6	11.6	40	5	4	7	9	6	7	11	7	10	14	8	11	15	10	14	18		
		46	90.7	46	10.6	12.7		10	4	6	9	6	8	12	7	9	14	8	11	17	9	13	19		
		51	95.5	51	11.3	13.7		15	4	6	8	5	7	11	7	9	15	8	11	16	9	13	19		
		58	102.7	58	12.8	15.5		22	4	5	8	5	7	11	6	9	14	7	11	18	9	13	18		
		176.209.1Y.01.00 176.409.1Y.01.00 176.509.1Y.01.00	0.10	2	21.7	2	1.1	2.0	15	5	8	12	18	11	15	24	13	18	28	16	21	30	18	26	32
				4	31.6	4	2.2	2.9		10	8	11	17	11	16	24	13	19	27	16	22	29	18	25	32
10	47.6			10	3.9	4.6	15	-		-	-	-	-	-	12	18	27	16	20	27	17	23	32		
15	58.4			15	5.0	5.9	22	-		-	-	-	-	-	12	18	27	15	21	30	17	23	32		
20	67.5			20	6.0	7.2	30	5	5	8	12	7	10	15	8	11	18	10	13	20	11	14	22		
25	75.4			25	6.8	8.3		10	5	7	11	7	9	14	8	11	18	9	13	22	11	15	24		
29	82.7			29	7.7	9.4		15	4	7	11	7	9	14	8	11	17	9	13	20	11	15	22		
35	89.5			35	8.7	10.4		22	-	-	-	-	-	-	8	10	17	9	12	18	10	15	22		
40	95.8			40	9.6	11.6	40	5	4	6	9	6	8	13	7	9	16	8	11	18	9	14	20		
46	101.7			46	10.4	12.7		10	4	6	9	6	7	12	7	9	16	8	11	18	9	14	22		
51	107.2			51	11.4	13.7		15	4	6	9	6	7	12	7	10	16	8	11	18	10	14	22		
58	115.4			58	12.8	15.5		22	4	6	8	6	7	12	7	10	16	8	11	18	9	13	20		
60	5			4	6	8	5	7	10	6	7	11	7	10	14	7	10	14	7	10	16				
	10			4	5	8	5	7	11	6	8	12	7	9	14	8	11	16	8	11	16				
	15	4	5	7	4	6	10	6	8	12	7	9	16	8	11	18	8	11	18						
	22	-	-	-	4	6	10	6	7	12	7	9	16	7	9	16	7	9	16						

Notice:
 The fourth digit in the order number (2, 4 or 5) stands for the housing variant (for details see Page139).
 * A cone-shaped spray pattern is produced without fan air.

➤ Spare parts set for pneumatic atomizing nozzles Series 176 ViscoMist

Overview of the spare parts set and the power set

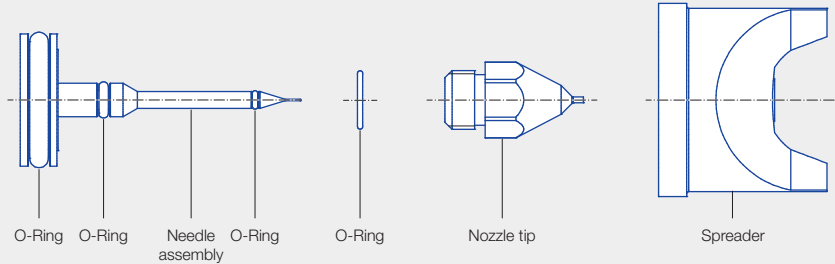

Spare parts set

Spare parts set for replacing the main wear parts of the nozzle, consisting of:

- Needle (stainless steel 316L)
- O-rings (Viton)
- Nozzle tip (stainless steel 316L)

Power set

Power set for replacing the main wear parts of the nozzle and the air hood, consisting of:

- Needle (stainless steel 316L)
- O-rings (Viton)
- Nozzle tip (stainless steel 316L)
- Spreader (stainless steel 316L)

Ordering number	Narrowest free cross section Ø [in]	For nozzles
Type		
017.601.1Y.01	0.015	176.xx1.1Y.11.00
017.602.1Y.01	0.023	176.xx2.1Y.11.00
017.603.1Y.01	0.03	176.xx3.1Y.11.00
017.604.1Y.01	0.042	176.xx4.1Y.11.00
017.605.1Y.01	0.052	176.xx5.1Y.11.00
017.606.1Y.01	0.067	176.xx6.1Y.11.00
017.607.1Y.01	0.081	176.xx7.1Y.11.00
017.608.1Y.01	0.093	176.xx8.1Y.11.00
017.609.1Y.01	0.100	176.xx9.1Y.11.00

Ordering number	Narrowest free cross section Ø [in]	For nozzles
Type		
017.601.1Y.00	0.015	176.xx1.1Y.11.00
017.602.1Y.00	0.023	176.xx2.1Y.11.00
017.603.1Y.00	0.031	176.xx3.1Y.11.00
017.604.1Y.00	0.042	176.xx4.1Y.11.00
017.605.1Y.00	0.052	176.xx5.1Y.11.00
017.606.1Y.00	0.067	176.xx6.1Y.11.00
017.607.1Y.00	0.081	176.xx7.1Y.11.00
017.608.1Y.00	0.093	176.xx8.1Y.11.00
017.609.1Y.00	0.100	176.xx9.1Y.11.00

Notice:

Instructions for replacing individual or all components of the nozzles are included in the scope of delivery of the spare parts sets and the power sets.

O-ring set

Type	Ordering number		Consisting of 4 O-rings, suitable for all nozzles of series 176
	Material number		
	7A	6C	
	Viton	EPDM	
017.600.xx.01.03	●	●	

Viton (7A) is the standard O-ring material.
EPDM (6C) is optionally available.

Ordering Type + Material no. = Ordering no.
example: 017.600.xx.01.03 + 7A = 017.600.7A.01.03

➤➤ HOLLOW CONE NOZZLES

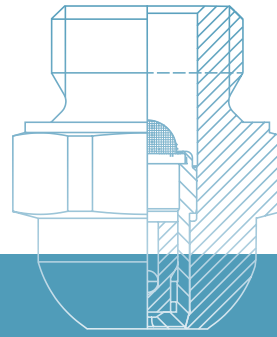

»» HOLLOW CONE NOZZLES OVERVIEW OF TYPES

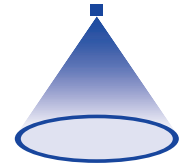

Hollow cone nozzles are used wherever fine droplets are required. A distinction is made between axial-flow hollow cone nozzles and tangential-flow hollow cone nozzles. Axial-flow hollow cone nozzles are mainly used for cooling, humidification and disinfecting, while tangential-flow hollow cone nozzles are traditionally used for humidification, dust control, sprinkling and foam control.

Axial-flow hollow cone nozzles

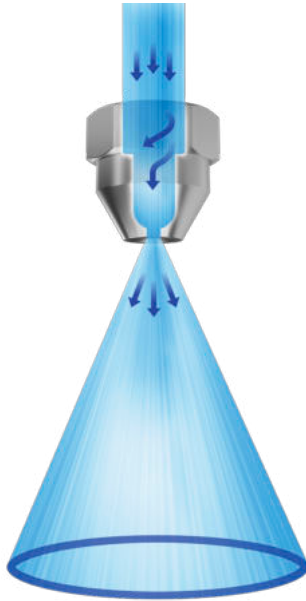

- High and controlled degree of atomization due to integrated swirl insert.
- Narrow droplet size spectrum.
- Uniform atomization.
- Large droplet surface area for mass transfer processes.

Tangential-flow hollow cone nozzles

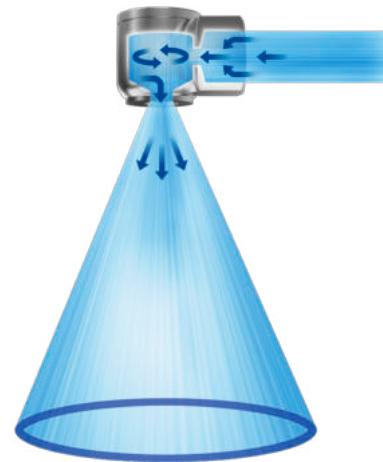







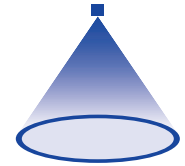

- Liquid rotation without swirl insert.
- Clog-resistant maximum free passage.
- Large free cross sections.
- Operational reliability.
- Coarse droplets that are larger than axial-flow hollow cone nozzles.









Hollow cone nozzles

HOLLOW CONE NOZZLES OVERVIEW OF SERIES



		Axial-flow hollow cone nozzles			
					
Series		220	226	214/216/218	2TR
Information on page		153	154	155	156
 Flow rate at p = 30 psi	Very low < 0.13 gal/min	• (at p = 75 psi)	• (at p = 75 psi)	• (at p = 75 psi)	• (at p = 75 psi)
	Low 0.13 gal/min–.53 gal/min			• (at p = 75 psi)	• (at p = 75 psi)
	Medium .53 gal/min–2.64 gal/min			• (at p = 75 psi)	
	High 2.64 gal/min–13.21 gal/min			• (at p = 75 psi)	
	Very high > 13.21 gal/min				
 Spray angle	Small 45°				
	Medium 55°–95°	•	•	•	•
	Large 130°				
 Nozzle material	Stainless steel	•	•	•	
	Brass			•	
	Plastic				•
 Nozzle connection		1/4 NPT	Assembly with retaining nut 3/8 NPT	1/8 NPT 1/4 NPT 3/8 NPT 1/2 NPT	Assembly with retaining nut 3/8 NPT

Tangential-flow hollow cone nozzles

					
302	302 with bayonet quick-release system	308	304/306/307	350	373 Ramp Bottom
157/158	158	161	162	163	162
•	•				
•	•	•		•	
•		•	•	•	
•			•		
					•
	•				
•	•	•	•		•
•	•		•	•	
•			•		•
•		•	•		
•	•			•	
3/8 NPT 3/8 BSPP	Assembly with bayonet quick-release system	3/8 BSPP	1/2 BSPP 3/4 BSPP	3/8 BSPP	1 NPT 1 1/4 NPT 1 1/2 NPT 2 NPT

➤ Axial-flow hollow cone nozzles Series 220

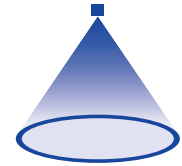

Features:

- Extremely fine, fog-like atomization

Applications:

- Humidification
- Cooling
- Disinfection
- Chemical engineering
- Adiabatic cooling

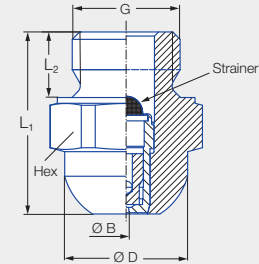

Series 220

Connection	G	Dimensions [in]				Weight [lb]
		L ₁	L ₂	Ø D	Hex (mm)	
BC	1/4 NPT	0.87	0.31	0.59	17	0.06

Spray angle	Ordering number				Bore diameter B [in]	Narrowest free cross section Ø [in]	Strainer insert mesh size [in]	V̇ water [gal/min]										Spray diameter D [in] (at p = 75 bar)
	Type	Mat. no.		Connection				p [psi]										
		1Y	11					30	45	75	Liters per min.	100	145	290	725	1450		
60°	220.004	●	●	BC	0.004	0.004	0.002	–	–	0.003	0.013	0.004	0.005	0.007	0.011	0.015	5	
	220.014	●	●	BC	0.006	0.006	0.002	–	0.004	0.005	0.019	0.006	0.007	0.010	0.016	0.022	6	
	220.054	●	●	BC	0.008	0.006	0.002	0.005	0.006	0.007	0.027	0.008	0.010	0.014	0.023	0.032	6	
80°	220.085	●	●	BC	0.010	0.010	0.004	0.007	0.008	0.011	0.040	0.012	0.015	0.021	0.033	0.047	7	
	220.125	●	●	BC	0.014	0.014	0.004	0.011	0.013	0.017	0.062	0.019	0.023	0.033	0.052	0.073	9	
	220.145	●	●	BC	0.016	0.016	0.004	0.014	0.017	0.022	0.082	0.025	0.031	0.043	0.068	0.097	10	
	220.165	●	●	BC	0.018	0.018	0.008	0.018	0.021	0.028	0.103	0.032	0.038	0.054	0.086	0.122	10	
	220.185	●	●	BC	0.022	0.014	0.008	0.022	0.027	0.035	0.130	0.040	0.049	0.069	0.109	0.154	11	
	220.205	●	●	BC	0.024	0.014	0.008	0.028	0.034	0.044	0.168	0.053	0.063	0.089	0.140	0.198	11	
	220.245	●	●	BC	0.028	0.020	0.008	0.044	0.054	0.070	0.261	0.081	0.097	0.138	0.218	0.308	11	
220.285	●	●	BC	0.035	0.022	0.004	0.066	0.081	0.105	0.390	0.121	0.146	0.206	0.326	0.461	12		

Also available in BSPP

Mat. no.	Housing	Nozzle insert	Strainer
1Y	Stainless steel 316L	Stainless steel 316L	Stainless steel 316L
11	Stainless steel 430F	Stainless steel 430F	Stainless steel 316L

The supplied and integrated strainer insert prevents clogging of the nozzle, thereby ensuring a long service life.

Conversion formula for this series: $\dot{V}_2 = \dot{V}_1 \cdot \sqrt{\frac{p_2}{p_1}}$

Ordering Type + Material no. + Code = Ordering no.
example: 220.004 + 1Y + BC = 220.004.1Y.BC

 Assembly accessories can be found in Chapter 12 "Accessories".

➤ Axial-flow hollow cone nozzles

Series 226

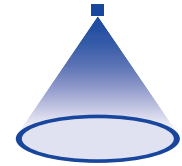

Features:

- Extremely fine, fog-like atomization
- Assembly with retaining nut

Applications:

- Humidification
- Cooling
- Disinfection
- Chemical engineering
- Adiabatic cooling



Series 226

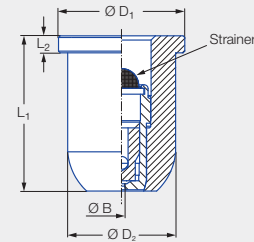

Connection	Dimensions [in]				Weight [lb]
	L ₁	L ₂	Ø D ₁	Ø D ₂	
Assembly with retaining nut 3/8 BSPP	0.71	0.08	0.58	0.50	0.04

Spray angle	Ordering number		Bore diameter B [in]	Narrowest free cross section Ø [in]	Strainer insert mesh size [in]	V̇ water [gal/min]										Spray diameter D [in] (at p = 75 psi)
	Type	Mat. no.				p [psi]										
		16				30	45	75	Liters per min. 5 bar	100	145	290	725	1450	H = 10 [in]	
60°	Stainless steel 303	226.004	●	0.004	0.004	0.002	–	–	0.003	0.013	0.004	0.005	0.007	0.011	0.015	5
		226.014	●	0.006	0.006	0.002	–	0.004	0.005	0.019	0.006	0.007	0.010	0.016	0.022	6
		226.054	●	0.008	0.006	0.002	0.005	0.006	0.007	0.027	0.008	0.010	0.014	0.023	0.032	6
80°	Stainless steel 303	226.085	●	0.010	0.010	0.004	0.007	0.008	0.011	0.040	0.012	0.015	0.021	0.033	0.047	7
		226.125	●	0.014	0.014	0.004	0.011	0.013	0.017	0.062	0.019	0.023	0.033	0.052	0.073	9
		226.145	●	0.016	0.016	0.004	0.014	0.017	0.022	0.082	0.025	0.031	0.043	0.068	0.097	10
		226.165	●	0.018	0.018	0.004	0.018	0.021	0.028	0.103	0.032	0.038	0.054	0.086	0.122	10
		226.185	●	0.022	0.014	0.008	0.022	0.027	0.035	0.130	0.040	0.049	0.069	0.109	0.154	11
		226.205	●	0.024	0.014	0.008	0.028	0.034	0.044	0.168	0.053	0.063	0.089	0.140	0.198	11
		226.245	●	0.028	0.020	0.008	0.044	0.054	0.070	0.261	0.081	0.097	0.138	0.218	0.308	11
226.285	●	0.035	0.022	0.008	0.066	0.081	0.105	0.390	0.121	0.146	0.206	0.326	0.461	12		

Mat. no.	Housing	Nozzle insert	Strainer
16	Stainless steel 303	Stainless steel 430F	Stainless steel 316L

The supplied and integrated strainer insert prevents clogging of the nozzle, thereby ensuring a long service life.

Conversion formula for this series: $\dot{V}_2 = \dot{V}_1 \cdot \sqrt{\frac{p_2}{p_1}}$

Ordering example: Type 226.004 + Material no. 16 = Ordering no. 226.004.16



Assembly accessories can be found in Chapter 12 "Accessories".

➤ Axial-flow hollow cone nozzles

Series 214/216/218

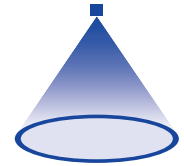

Features:

- Fine, uniform atomization

Applications:

- Cooling
- Gas washing
- Dust control
- Sprinkling
- Adiabatic cooling



Series 214/216/218

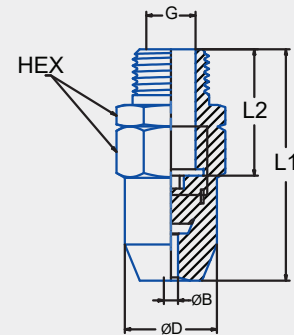

Ordering no.	Dimensions [in]					Weight [lb]
	Thread size Male NPT	Hex (mm)	L ₁	L ₂	Ø D ₁	
214.xxx.YY.BA	1/8	17	1.531	0.718	0.625	0.15
214.xxx.YY.BC	1/4	17	1.593	0.718	0.625	0.20
216.xxx.YY.BC	1/4	22	1.468	1.156	0.843	0.25
216.xxx.YY.BE	3/8	22	1.468	1.156	0.843	0.25
218.xxx.YY.BG	1/2	27	2.531	1.406	1.031	0.30

Spray angle	Ordering number								Bore diameter B [in]	Narrowest free cross section Ø [in]	V̇ water [gal/min]							Spray diameter D [in] (at p = 75 bar)
	Type	Mat. no.		Connection Male NPT				p [psi]										
		17	30	1/8"	1/4"	3/8"	1/2"	10			15	30	45	75	Liters per min. 5 bar	145	290	
								Stainless steel 316Ti			Brass	BA	BC	BE		BE	BE	
60°	214.184	●	●	BA	BC			0.020	0.020	–	–	0.02	0.027	0.035	0.13	0.05	0.07	5
	216.324	●	●		BC	BE		0.039	0.039	–	0.08	0.11	0.13	0.17	0.63	0.24	0.33	7
	216.364	●	●		BC	BE		0.055	0.055	–	0.12	0.17	0.21	0.27	1.00	0.37	0.53	9
	216.404	●	●		BC	BE		0.079	0.079	–	0.19	0.27	0.33	0.42	1.58	0.59	0.83	9
80°	214.245	●	●	BA	BC			0.039	0.020	–	–	0.04	0.05	0.07	0.25	0.10	0.13	9
	214.305	●	●	BA	BC			0.071	0.020	–	0.06	0.09	0.11	0.14	0.51	0.19	0.27	13
90°	216.496	●	●		BC	BE		0.118	0.079	–	0.32	0.46	0.56	0.72	2.69	1.00	1.42	17
	216.566	●	●		BC	BE		0.157	0.079	–	0.47	0.67	0.82	1.06	3.95	1.48	2.09	17
	216.646	●	●		BC	BE		0.138	0.079	0.62	0.76	1.07	1.32	1.70	6.32	2.36	3.34	17
	216.686	●	●		BC	BE		0.157	0.079	0.78	0.95	1.34	1.65	2.13	7.91	2.95	4.18	18
	216.726	●	●		BC	BE		0.197	0.079	0.98	1.20	1.69	2.07	2.68	9.96	3.72	5.26	18
	216.776	●	●		BC	BE		0.234	0.079	1.31	1.61	2.28	2.79	3.60	13.40	5.01	7.08	19
	218.646	●	●				BG	0.197	0.079	0.62	0.76	1.07	1.32	1.70	6.32	2.36	3.34	20
	218.666	●	●				BG	0.217	0.079	0.70	0.86	1.21	1.48	1.91	7.12	2.66	3.76	20
	218.706	●	●				BG	0.256	0.079	0.87	1.06	1.50	1.84	2.38	8.85	3.31	4.68	20
	218.766	●	●				BG	0.197	0.079	1.24	1.52	2.15	2.63	3.40	12.65	4.73	6.68	20
	218.826	●	●				BG	0.256	0.079	1.74	2.13	3.01	3.69	4.76	17.71	6.62	9.36	20
	218.846	●	●				BG	0.300	0.079	1.94	2.37	3.36	4.11	5.31	19.76	7.38	10.44	20
218.886	●	●				BG	0.354	0.094	2.48	3.04	4.30	5.26	6.80	25.30	9.45	13.37	20	

Also available in BSPP

Conversion formula for this series: $\dot{V}_2 = \dot{V}_1 \cdot \sqrt{\frac{p_2}{p_1}}$

Ordering Type + Material no. + Code = Ordering no.
 example: 214.184 + 17 + BC = 214.184.17.BC

Assembly accessories can be found in Chapter 12 "Accessories".



➤ Axial-flow hollow cone nozzles

Series 2TR

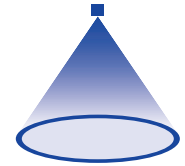

Features:

- Fine, uniform atomization
- Assembly with retaining nut

Applications:

- Sprinkling
- Adiabatic cooling
- Cooling
- Humidification of air



Series 2TR

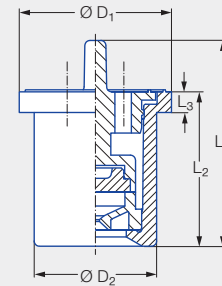

Connection	Dimensions [in]					Weight [lb]
	L ₁	L ₂	L ₃	Ø D ₁	Ø D ₂	
Assembly with retaining nut 3/8 BSPP	0.79	0.59	0.08	0.58	0.47	0.007

Spray angle	Ordering number		Color	Bore diameter B [in]	Narrowest free cross section Ø [in]	V̇ water [gal/min]							Spray diameter D [in] (at p = 75 bar)
	Type	Mat. no.				p [psi]							
		C8				Housing: POM Insert: Ceramic	15	30	45	75	Liters per min. 5 bar	100	145
80°	2TR.245	●	Purple	0.026	0.022	–	0.04	0.05	0.07	0.25	0.08	0.09	9
	2TR.275	●	Black	0.032	0.028	0.04	0.06	0.07	0.09	0.35	0.11	0.13	10
	2TR.305	●	Orange	0.035	0.032	0.06	0.09	0.11	0.14	0.51	0.16	0.19	13
	2TR.345	●	Green	0.043	0.035	0.09	0.13	0.16	0.20	0.76	0.24	0.28	17
	2TR.365	●	Yellow	0.055	0.037	0.12	0.18	0.21	0.28	1.03	0.32	0.38	19
	2TR.405	●	Blue	0.067	0.043	0.18	0.26	0.32	0.41	1.53	0.47	0.57	21
	2TR.445	●	Red	0.079	0.047	0.24	0.34	0.42	0.54	2.02	0.63	0.75	22
2TR.485	●	Brown	0.087	0.051	0.30	0.42	0.52	0.67	2.50	0.78	0.93	22	

Assembly example



Conversion formula for this series: $\dot{V}_2 = \dot{V}_1 \cdot \sqrt{\frac{p_2}{p_1}}$

Ordering example: Type 2TR.245 + Material no. C8 = Ordering no. 2TR.245.C8



Assembly accessories can be found in Chapter 12 "Accessories".

➤ Tangential-flow hollow cone nozzles, stainless steel/brass version

Series 302

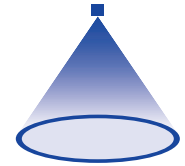

Features:

- Uniform atomization
- Clog-resistant nozzle without swirl insert

Applications:

- Humidification
- Dust control
- Sprinkling
- Foam control
- Adiabatic cooling

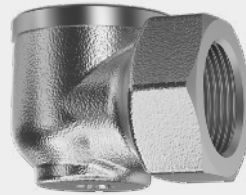

Series 302

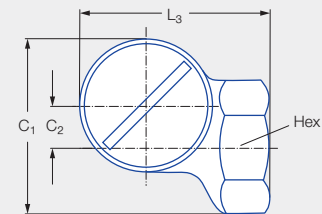
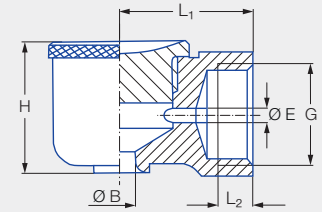

G	Dimensions [in]							Weight [lb] (Brass)
	C ₁	C ₂	H	L ₁	L ₂	L ₃	Hex (mm)	
3/8 BSPP	1.34	0.31	0.91	0.91	0.26	1.42	22	0.20

Spray angle	Ordering number				Bore diameter B [in]	Narrowest free cross section Ø [in]	V̇ water [gal/min]								Spray diameter D [mm] (at p = 30 psi)	
	Type	Mat. no.		C onn.			p [psi]								H = 10 [in]	H = 20 [in]
		1Y	30				10	15	30	Liters per min. 2 bar	45	75	100	145		
60°	302.364	●	●	00	0.06	0.06	0.10	0.12	0.17	0.63	0.21	0.27	0.31	0.37	11	17
	302.464	●	●	00	0.08	0.08	0.22	0.27	0.38	1.40	0.46	0.59	0.69	0.83	11	18
80°	302.545	●	●	00	0.19	0.09	0.35	0.43	0.60	2.24	0.74	0.95	1.10	1.32	14	26
90°	302.606	●	●	00	0.18	0.16	0.49	0.60	0.85	3.15	1.04	1.34	1.55	1.86	19	32
130°	302.368	●	●	00	0.12	0.04	0.10	0.12	0.17	0.63	0.21	0.27	0.31	0.37	26	43
	302.468	●	●	00	0.20	0.07	0.22	0.27	0.38	1.40	0.46	0.59	0.69	0.83	32	54
	302.548	●	●	00	0.20	0.10	0.35	0.43	0.60	2.24	0.74	0.95	1.10	1.32	38	65
	302.608	●	●	00	0.20	0.14	0.49	0.60	0.85	3.15	1.04	1.34	1.55	1.86	42	71
	302.668	●	●	00	0.30	0.14	0.70	0.85	1.21	4.50	1.48	1.91	2.21	2.66	44	77
	302.748	●	●	00	0.30	0.19	1.10	1.35	1.91	7.10	2.34	3.02	3.48	4.19	46	85

Available in NPT with adapter add-on.

Conversion formula for this series: $\dot{V}_2 = \dot{V}_1 \cdot \sqrt{\frac{p_2}{p_1}}$

Ordering Type + Material no. + Code = Ordering no.
 example: 302.364 + 30 + 00 = 302.364.30.00



Assembly accessories can be found in Chapter 12 "Accessories".

➤ Tangential-flow hollow cone nozzles, plastic version

Series 302

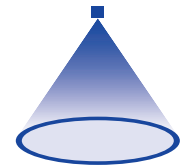

Features:

- Uniform atomization
- Clog resistant nozzle without swirl insert

Applications:

- Humidification
- Dust control
- Sprinkling
- Foam control
- Adiabatic cooling

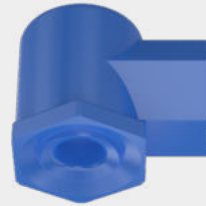

Series 302

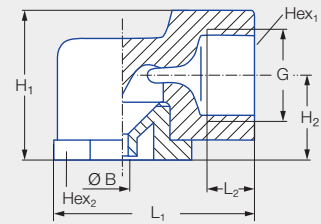

Type 302.32x-302.48x

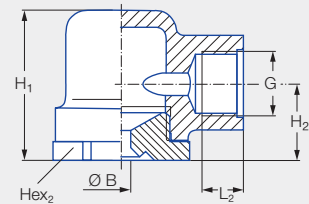

Type 302.52x-302.96x

Type	G	Dimensions [in]						Weight [lb]	P _{max} [psi]
		H ₁	H ₂	L ₁	L ₂	Hex ₁ (mm)	Hex ₂ (mm)		
302.32x-302.48x	3/8 NPT/BSPP	1.08	0.65	1.71	0.39	22	22	0.03	75
302.52x-302.96x	3/8 NPT/BSPP	1.34	0.73	1.46	0.39	22	22	0.04	75

Spray angle	Ordering number						Bore diameter B [in]	Narrowest free cross section Ø [in]	V̇ water [gal/min]						Spray diameter D [in] (at p = 30 psi)	
	Type	Mat. no.			Connection				p [psi]							
		51	5E	53	Female											
		PA	PVDF	PP	3/8" NPT	3/8" BSPP			10	15	30	Liters per min.	45	75	H = 10 [in]	H = 20 [in]
60°	302.364	●		●	-	00	0.05	0.05	0.10	0.12	0.17	0.63	0.21	0.27	13	24
	302.464	●		●	-	00	0.08	0.08	0.22	0.27	0.38	1.40	0.46	0.59	13	24
90°	302.326	●	●		-	00	0.04	0.04	0.06	0.08	0.11	0.40	0.13	0.17	19	30
	302.366	●	●		-	00	0.05	0.05	0.10	0.12	0.17	0.63	0.21	0.27	19	31
	302.406	●	●	●	-	00	0.06	0.06	0.16	0.19	0.27	1.00	0.33	0.42	19	32
	302.486	●		●	-	00	0.08	0.08	0.25	0.30	0.43	1.60	0.53	0.68	20	33
	302.526	●		●	BF	00	0.20	0.08	0.31	0.38	0.54	2.00	0.66	0.85	20	34
	302.566	●		●	-	00	0.20	0.09	0.39	0.47	0.67	2.50	0.82	1.06	20	35
	302.606	●		●	BF	00	0.20	0.13	0.49	0.60	0.85	3.15	1.04	1.34	21	37
	302.686	●			BF	00	0.30	0.13	0.78	0.95	1.34	5.00	1.65	2.12	21	40
	302.766	●			BF	00	0.35	0.17	1.24	1.52	2.15	8.00	2.63	3.40	21	41
	302.846	●		●	BF	00	0.43	0.20	1.94	2.37	3.36	12.50	4.11	5.31	21	41
302.886	●	●	●	BF	00	0.43	0.25	2.48	3.04	4.30	16.00	5.26	6.80	21	41	
302.966	●			BF	00	0.43	0.34	3.88	4.75	6.72	25.00	8.23	10.62	21	41	



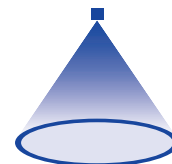

Spray angle	Ordering number						Bore diameter B [in]	Narrowest free cross section Ø [in]	V̇ water [gal/min]						Spray diameter D [in] (at p = 30 psi)	
	Type	Mat. no.			Connection				p [psi]							
		51	5E	53	Female				10	15	30	Liters per min. 2 bar	45	75		
		PA	PVDF	PP	3/8" NPT	3/8" BSPP										
130°	302.328		●			00	0.05	0.03	0.06	0.08	0.11	0.40	0.13	0.17	25	37
	302.368	●	●			00	0.07	0.04	0.10	0.12	0.17	0.63	0.21	0.27	26	40
	302.408	●	●			00	0.14	0.05	0.16	0.19	0.27	1.00	0.33	0.42	27	44
	302.488	●		●		00	0.20	0.06	0.25	0.30	0.43	1.60	0.53	0.68	28	49
	302.528	●			BF	00	0.20	0.08	0.31	0.38	0.54	2.00	0.66	0.85	30	52
	302.568	●				00	0.20	0.09	0.39	0.47	0.67	2.50	0.82	1.06	31	56
	302.608	●	*●	●	BF	00*	0.20	0.13	0.49	0.60	0.85	3.15	1.04	1.34	32	59
	302.648	●			BF	00	0.30	0.12	0.62	0.76	1.07	4.00	1.32	1.70	34	63
	302.688	●			BF	00	0.30	0.13	0.78	0.95	1.34	5.00	1.65	2.12	35	65
	302.728	●			BF	00	0.30	0.16	0.98	1.20	1.69	6.30	2.07	2.68	36	67
	302.768	●			BF	00	0.35	0.17	1.24	1.52	2.15	8.00	2.63	3.40	37	68
	302.848	●			BF	00	0.43	0.20	1.94	2.37	3.36	12.50	4.11	5.31	38	69
	302.888	●		●	BF	00	0.43	0.25	2.48	3.04	4.30	16.00	5.26	6.80	38	70
302.968	*●	●		BF	00*	0.43	0.34	3.88	4.75	6.72	25.00	8.23	10.62	39	71	

* Material only available in BSPP

Conversion formula for this series: $\dot{V}_2 = \dot{V}_1 \cdot \sqrt{\frac{p_2}{p_1}}$

Ordering Type + Material no. = Ordering no.
 example: 302.328 + 5E = 302.328.5E

Assembly accessories can be found in Chapter 12 "Accessories".

➤ Tangential-flow hollow cone nozzles, plastic version with bayonet quick-release system

Series 302

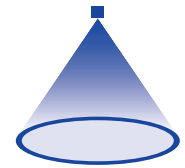

Features:

- Uniform atomization
- Clog-resistant nozzle without swirl insert
- Quick and secure assembly thanks to bayonet quick-release system
- Fixed alignment

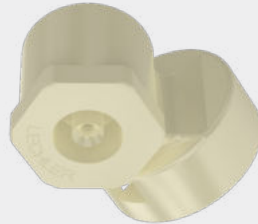

Series 302

Applications:

- Humidification
- Dust control
- Sprinkling
- Foam control
- Adiabatic cooling

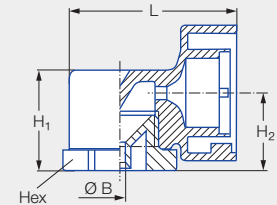

Type 302.32x-302.54x

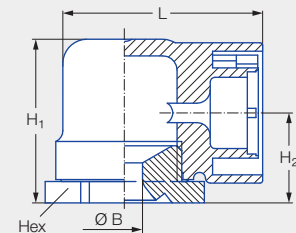

Type 302.6xx.51.KB

Type	Connection	Dimensions [in]				Weight [lb]	P _{max} [psi]
		H ₁	H ₂	L	Hex (mm)		
302.32x-302.54x	KB	0.86	0.66	1.42	22	0.03	75
302.6xx.51	KB	1.34	0.75	1.65	30	0.04	75

Spray angle	Ordering number				Bore diameter B [in]	Narrowest free cross section Ø [in]	V̇ water [gal/min]						Spray diameter D [in] (at p = 30 psi)	
	Type	Mat. no.		Connection			p [psi]						H = 10 [in]	H = 20 [in]
		51	56				10	15	30	Liters per min. 2 bar	45	75		
45°	302.503	●		KB	0.081	0.081	0.28	0.34	0.48	1.80	0.59	0.76	8	17
60°	302.464		●	KB	0.077	0.077	0.22	0.27	0.38	1.40	0.46	0.59	11	21
80°	302.545		●	KB	0.091	0.091	0.35	0.43	0.60	2.24	0.74	0.95	18	32
90°	302.326	●	●	KB	0.041	0.041	0.06	0.08	0.11	0.40	0.13	0.17	16	28
	302.406	●	●	KB	0.061	0.061	0.16	0.19	0.27	1.00	0.33	0.42	16	29
	302.486	●		KB	0.083	0.083	0.25	0.30	0.43	1.60	0.53	0.68	18	31
	302.606	●		KB	0.197	0.126	0.49	0.60	0.85	3.15	1.04	1.34	21	39
130°	302.686		●	KB	0.300	0.133	0.78	0.95	1.34	5.00	1.65	2.12	21	40
	302.368		●	KB	0.051	0.051	0.10	0.12	0.17	0.63	0.21	0.27	26	43
	302.408	●	●	KB	0.079	0.079	0.16	0.19	0.27	1.00	0.33	0.42	27	47
	302.468	●		KB	0.094	0.094	0.22	0.27	0.38	1.40	0.46	0.59	27	49
	302.488	●		KB	0.108	0.108	0.25	0.30	0.43	1.60	0.53	0.68	28	51

Conversion formula for this series: $\dot{V}_2 = \dot{V}_1 \cdot \sqrt{\frac{p_2}{p_1}}$

Ordering example: Type 302.503 + Material no. 51 + Code KB = Ordering no. 302.503.51.KB



Assembly accessories can be found in Chapter 12 "Accessories".

➤ Tangential-flow hollow cone nozzles

Series 308

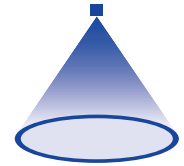

Features:

- Uniform atomization
- Clog-resistant nozzle without swirl insert
- Adjustable flow rate

Applications:

- Humidification in air washers
- Dust control
- Spraying onto filters
- Foam control
- Cooling



Series 308

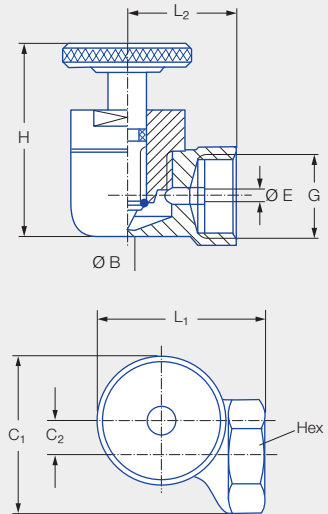

G	Dimensions [in]						Weight [lb]
	C ₁	C ₂	H	L ₁	L ₂	Hex (mm)	
3/8 BSPP	1.34	0.31	1.57	1.42	0.91	22	0.33

Spray angle	Ordering number		Bore diameter B [in]	Narrowest free cross section Ø [in]	\dot{V}_{\max} water [gal/min]							Spray diameter D [in] (at p = 30 psi)		
	Type	Mat. no.			p [psi]									
		30			5		10		15		30			H = 10 [in]
		Brass								Liters per min.				
										2 bar				
90°	308.466	●	0.08	0.08	0.15	0.22	0.27	0.38	1.40	0.59	0.83	17	33	
	308.606	●	0.16	0.16	0.35	0.49	0.60	0.85	3.15	1.34	1.86	18	33	

Conversion formula for this series: $\dot{V}_2 = \dot{V}_1 \cdot \sqrt{\frac{p_2}{p_1}}$

Ordering Type + Material no. = Ordering no.
example: 308.466 + 30 = 308.466.30



Assembly accessories can be found in Chapter 12 "Accessories".

➤ Tangential-flow hollow cone nozzles

Series 304/306/307

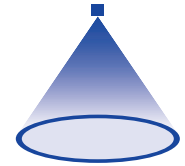

Features:

- Uniform atomization
- Clog-resistant nozzle without swirl insert

Applications:

- Storage tank cooling
- Foam control
- Dust control
- Surface treatment
- Absorption



Series 304/306/307

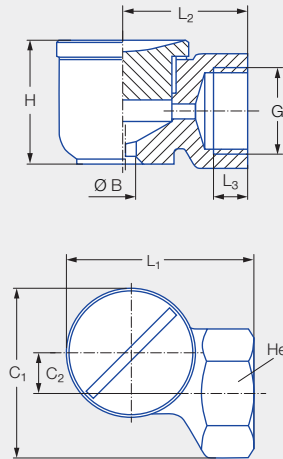

Series	G	Dimensions [in]							Weight [lb] (Brass)
		C ₁	C ₂	H	L ₁	L ₂	L ₃	Hex (mm)	
304	1/2 BSPP	1.69	0.43	1.30	1.81	1.18	0.43	27	0.45
306/307	3/4 BSPP	2.13	0.51	1.69	2.36	1.57	0.51	36	0.90

Spray angle	Ordering number		Bore diameter B [in]	Narrowest free cross section Ø [in]	V̇ water [gal/min]								Spray diameter D [in] (at p = 30 psi)		
	Type	Mat. no.			p [psi]								H = 10 [in]	H = 20 [in]	
		1Y			30	5	10	30	Liters per min. 2 bar	45	75	100			145
90°	304.706	●	●	0.201	0.201	0.61	0.87	1.50	5.60	1.84	2.38	2.75	3.31	20	39
	304.796	●	●	0.350	0.236	1.04	1.47	2.55	9.50	3.13	4.04	4.66	5.61	20	39
	306.906	●	●	0.354	0.354	1.97	2.79	4.84	18.00	5.92	7.65	8.83	10.63	22	41
	306.976	●	●	0.531	0.394	2.91	4.11	7.12	26.50	8.72	11.26	13.00	15.65	22	41
130°	304.818	●	●	0.472	0.197	1.16	1.64	2.85	10.60	3.49	4.50	5.20	6.26	47	83
	304.898	●	●	0.472	0.276	1.86	2.64	4.57	17.00	5.59	7.22	8.34	10.04	49	87
	306.978	●	●	0.748	0.287	2.91	4.11	7.12	26.50	8.72	11.26	13.00	15.65	51	93
	307.018	●	●	0.748	0.339	3.67	5.20	9.00	33.50	11.02	14.23	16.43	19.79	51	93

Available in NPT with adaptor add-on.

Conversion formula for this series: $\dot{V}_2 = \dot{V}_1 \cdot \sqrt{\frac{p_2}{p_1}}$

Ordering Type + Material no. = Ordering no.
example: 304.706 + 1Y = 304.706.1Y



Assembly accessories can be found in Chapter 12 "Accessories".

➤ Tangential-flow hollow cone nozzles

Series 350

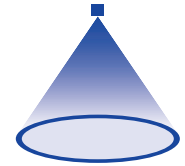

Features:

- High performance nozzle for humidification
- Very narrow droplet size spectrum
- Extremely uniform liquid distribution over the entire spray pattern
- Quick-release clamp unit available for pipe mounting

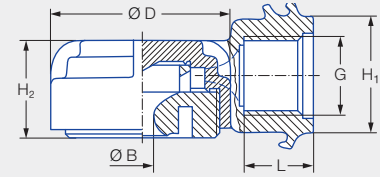
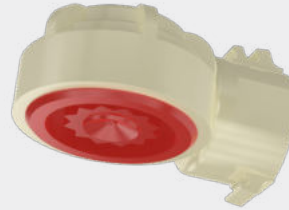

Applications:

- Foam control
- Dust control
- Surface treatment
- Absorption

Series 350

G	Dimensions [in]				Weight [lb]	P _{max} [psi]
	H ₁	H ₂	L	Ø D		
3/8 BSPP	0.94	0.79	0.55	1.46	0.08	300

Spray angle	Ordering number		Bore diameter B [in]	Narrowest free cross section Ø [in]	V̇ water [gal/min]								Spray diameter D [in] (at p = 30 psi)	
	Type	Mat. no.			p [psi]								H = 10 [in]	H = 20 [in]
		56			10	15	30	Liters per min. 2 bar	45	75	100	145		
130°	350.368	●	0.06	0.03	0.10	0.12	0.17	0.63	0.21	0.27	0.31	0.37	37	49
	350.608	●	0.20	0.06	0.49	0.60	0.85	3.15	1.04	1.34	1.55	1.86	39	77

Accessories:

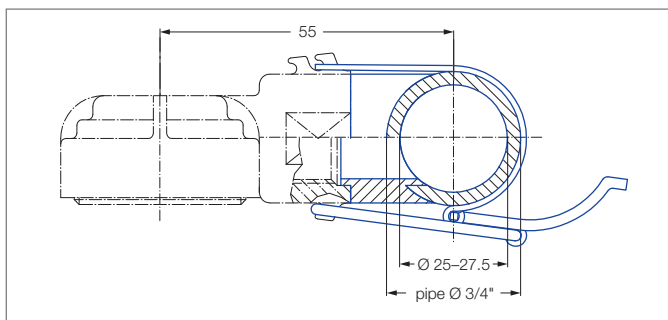

Recommended bore diameter 18 mm.

Quick-release clamp unit: Ordering no. 035.030.15.05.00.0.

Consisting of: Stainless steel clamp, polyurethane gasket.

Conversion formula for this series: $\dot{V}_2 = \dot{V}_1 \cdot \sqrt{\frac{p_2}{p_1}}$

Ordering Type + Material no. = Ordering no.
example: 350.368 + 56 = 350.368.56



Assembly accessories can be found in Chapter 12 "Accessories".

➤ Eccentric hollow cone nozzles

Series 373 Ramp Bottom

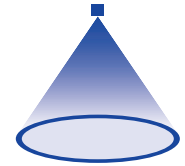

Features:

- Fine, uniform atomization even at low pressure
- Patented swirl chamber with built-in ramp extends service life

Applications:

- Gas cooling
- Water recooling
- Dust control



Series 373

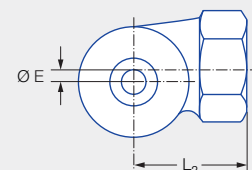
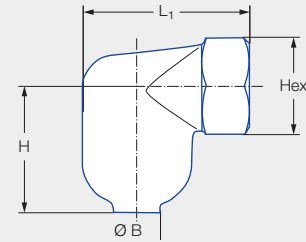

Connection	G	Dimensions [in]					Weight [lb]
		H	L ₁	L ₂	E	Hex (mm)	
BN	1 NPT	2.05	2.64	1.77	0.25	41	0.6
BQ	1 1/4 NPT	2.56	3.03	2.01	0.31	48	1.2
BS	1 1/2 NPT	3.19	3.82	2.56	0.31	58	2.0
BW	2 NPT	3.69	4.25	4.50	0.50	71	2.7

Spray angle (at p = 40 psi)	Ordering number					Bore diameter B [in]	V̇ water [gal/min]						Spray diameter D [in] (at p = 30 psi)		
	Type	Mat. no.	Connection				p [psi]						 H = 20 [in] H = 40 [in]		
		17	Female												
		Stainless steel 316	1 NPT	1 1/4 NPT	1 1/2 NPT		2 NPT	5	10	15	30	Liters per min. 2 bar	75	145	
70°	373.115	●	BN			0.45	6.91	9.77	11.97	16.93	63	26.76	37.21	26	47
80°	373.175	●	BN			0.51	8.77	12.41	15.2	21.49	80	33.98	47.25	31	57
75°	373.235	●		BQ		0.64	12.94	18.30	22.42	31.70	118	50.12	69.69	30	51
85°	373.285	●		BQ		0.81	17.55	24.82	30.39	42.98	160	67.96	94.50	31	53
85	373.325	●			BS	0.87	21.94	31.02	37.99	53.73	200	84.96	118.13	35	59
77°	373.365	●			BS	0.93	24.90	35.21	43.12	60.98	227	96.42	134.07	33	55
80°	373.445	●			BW	1.14	44.53	62.97	77.13	109.07	406	172.46	239.80	39	67
90°	373.465	●			BW	1.21	50.56	71.50	87.57	123.85	461	195.82	272.28	46	80

Other sizes and flow rates available upon request

Conversion formula for this series: $\dot{V}_2 = \dot{V}_1 \cdot \sqrt{\frac{p_2}{p_1}}$

Ordering Type + Material no. + Code = Ordering no.
 example: 373.115 + 17 + BN = 373.115.17.BN



Assembly accessories can be found in Chapter 12 "Accessories".

➤➤ FULL CONE NOZZLES

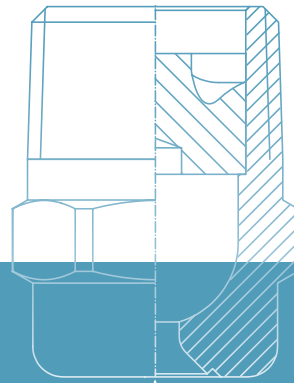

➤ FULL CONE NOZZLES OVERVIEW OF TYPES

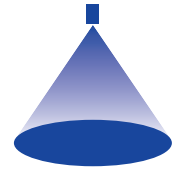

Lechler full cone nozzles are characterised by uniform liquid distribution over the entire circular impact area and are used, among other things, for surface spraying, in cleaning and washing processes and also in chemical process engineering. Full cone nozzles come in a variety of sizes and are made available as an axial full cone or a tangential full cone design. For special applications, unique types are made available, e.g. cluster head nozzles and deflector-plate nozzles.

Axial-flow full cone nozzles



- Axial flow
- Uniform liquid distribution
- Full surface impact
- Extensive flow rate range
- Extensive range of spray angles
- Standard materials:
Stainless steel 316Ti/316L, Brass, PVDF (special material available on request)

Tangential-flow full cone nozzles



- Tangential flow
- Uniform liquid distribution
- Full surface impact
- Maximum free passage making less susceptible to clogging
- Stable spray angle
- Standard materials:
Stainless steel 316L, Brass, PVDF (special material available on request)

Cluster head nozzles

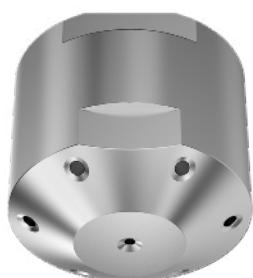

- Axial flow
- Multi-nozzle spray head
- Full surface impact
- Atomized spray – very fine droplets
- Small droplet sizes
- Enlarged droplet surface area
- Standard materials:
Stainless steel 316Ti/316L, Brass
(special material available on request)

Deflector-plate nozzles







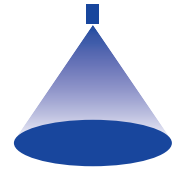











- Axial flow
- Large impact area
- Large free cross sections
- Standard materials:
Stainless steel 316Ti/316L, Brass
(special material available on request)

FULL CONE NOZZLES OVERVIEW OF SERIES



Axial-flow full cone nozzles

							
Series		460/461	490/491	468	452	405	459
Information on page		171	173	174	175	178	177
 Flow rate at p = 30 psi	Very low < 1.32 gal/min	•	•	•	•		
	Low 1.32 gal/min–6.6 gal/min	•	•	•	•		
	Medium 6.6 gal/min–21.13 gal/min	•	•				•
	High 21.13 gal/min–105.67 gal/min					•	•
	Very high > 105.67 gal/min						•
 Spray angle	Small 45°		•		•		•
	Medium 60°-90°	•	•	•		•	•
	Large ≥ 120°	•	•	•		•	•
 Nozzle material	Stainless steel		•	•	•	•	•
	Brass		•	•	•	•	
	Plastic	•		•			
 Nozzle connection		1/8 NPT 1/4 NPT 3/8 NPT 1/2 NPT 3/4 NPT 3/4 NPT 1 NPT	1/8 NPT 1/4 NPT 3/8 NPT 1/2 NPT 3/4 NPT 3/4 NPT 1 NPT	Assembly with retaining nut 3/8 NPT	1/4 NPT 3/8 NPT	1 1/4 NPT 1 1/2 NPT 2 NPT	1 1/2NPT 2 NPT 2 1/2 NPT 3 NPT

			Tangential-flow full cone nozzles		Cluster head nozzles	Deflector-plate nozzles
						
403	419	485	422/423	422 with bayonet quick-release system	502/503	524/525
180	179	180	183/186	188	189	190
			•	•	•	
			•		•	•
			•		•	•
	• (at p = 15 psi)	•	•			•
•	• (at p = 15 psi)	•				
•	•	•	•	•	•	
•	•		•	•	•	•
•	•	•	•		•	•
			•		•	•
			•	•		
2 1/2 NPT 3 NPT 3 1/2 NPT 4 NPT	2 NPT 2 1/2 NPT 3 NPT	4 NPT 5 NPT 6 NPT 8 NPT	1/4 NPT 3/8 NPT 1/2 NPT 3/4 NPT 1 NPT	Assembly with bayonet quick-release system	1/2 NPT 3/4 NPT	1/2 NPT

➤ Axial-flow full cone nozzles Series 460/461

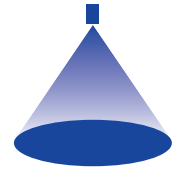

Features:

- Extremely uniform liquid distribution

Applications:

- Cleaning and washing processes
- Cooling
- Surface spraying
- Chemical process engineering



Series 460/461

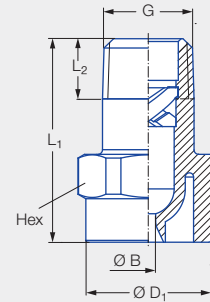

Figure 1

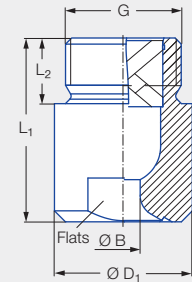

Figure 2

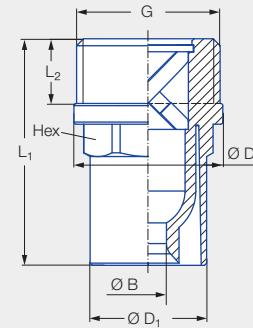
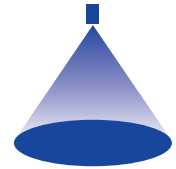

Figure 3

Connection	Figure	G	Dimensions [in]					Weight [lb]
			L ₁	L ₂	Ø D ₁	Ø D ₂	Hex (mm)	
BA	1	1/8 NPT	0.87	0.26	0.51	–	14	0.006
BC	1	1/4 NPT	0.87	0.38	0.51	–	14	0.007
BE	1	3/8 NPT	1.18	0.39	0.67	–	17	0.014
BG	1	1/2 NPT	1.71	0.52	0.87	–	22	0.032
BK	2	3/4 NPT	1.65	0.59	1.24	–	27	0.044
BM	3	1 NPT	2.07	0.59	1.06	1.36	27	0.076

Spray angle	Ordering number							Bore diameter B [in]	Narrowest free cross sections Ø [in]	V̇ water [gal/min]							Spray diameter D [in] (at p = 30 psi)					
	Type	Mat. no.	Connection							p [psi]												
			5E	1/8 NPT	1/4 NPT	3/8 NPT	1/2 NPT			3/4 NPT	1 NPT	7	15	30	Liters per min. 2 bar				45	60	75	145
															2.00	0.63	0.71	0.77				
60°	460.524	●	BA						0.063	0.063	0.30	0.41	0.54	2.00	0.63	0.71	0.77	1.01	8	15		
	460.644	●		BC					0.094	0.075	0.60	0.81	1.07	4.00	1.26	1.41	1.55	2.01	9	17		
	460.724	●		BC					0.110	0.083	0.94	1.28	1.69	6.30	1.98	2.23	2.43	3.17	10	18		
	460.964	●					BK		0.228	0.193	3.74	5.07	6.69	25.00	7.87	8.83	9.66	12.57	12	22		





Spray angle	Ordering number								Bore diameter B [in]	Narrowest free cross sections Ø [in]	V̇ water [gal/min]								Spray diameter D [in] (at p = 30 psi)	
	Type	Mat. no.	Connection								p [psi]								H = 10 [in]	H = 20 [in]
		5E	1/8 NPT	1/4 NPT	3/8 NPT	1/2 NPT	3/4 NPT	1 NPT			7	15	30	Liters per min. 2 bar	45	60	75	145		
		PVDF																		
90°	460.326	●	BA						0.031	0.022	0.06	0.08	0.11	0.40	0.13	0.14	0.15	0.20	17	30
	460.406	●	BA						0.047	0.033	0.15	0.20	0.27	1.00	0.31	0.35	0.39	0.50	17	31
	460.486	●	BA						0.057	0.047	0.24	0.32	0.43	1.60	0.50	0.57	0.62	0.80	18	31
	460.526	●	BA						0.065	0.051	0.30	0.41	0.54	2.00	0.63	0.71	0.77	1.01	18	32
	460.606	●	BA		BE				0.081	0.057	0.47	0.64	0.84	3.15	0.99	1.11	1.22	1.58	19	33
	460.646	●		BC					0.091	0.071	0.60	0.81	1.07	4.00	1.26	1.41	1.55	2.01	19	34
	460.726	●			BE				0.116	0.079	0.94	1.28	1.69	6.30	1.98	2.23	2.43	3.17	20	35
	460.746	●			BE				0.130	0.075	1.06	1.44	1.90	7.10	2.24	2.51	2.74	3.57	20	36
	460.766	●			BE				0.130	0.094	1.20	1.62	2.14	8.00	2.52	2.83	3.09	4.02	20	36
	460.806	●			BE				0.146	0.106	1.50	2.03	2.68	10.00	3.15	3.53	3.86	5.03	20	36
	460.846	●			BE				0.159	0.126	1.87	2.54	3.35	12.50	3.94	4.42	4.83	6.29	20	37
	460.886	●			BE	BG			0.185	0.122	2.39	3.25	4.28	16.00	5.04	5.65	6.18	8.05	20	37
	460.926	●				BG			0.201	0.110	2.99	4.06	5.36	20.00	6.30	7.07	7.73	10.06	20	37
	460.966	●				BG			0.228	0.150	3.74	5.07	6.69	25.00	7.87	8.83	9.66	12.57	20	37
	461.006	●				BG			0.252	0.150	4.71	6.39	8.43	31.50	9.92	11.13	12.17	15.84	20	37
	461.046	●					BK ¹		0.283	0.209	5.98	8.12	10.71	40.00	12.60	14.13	15.45	20.11	20	37
	461.086	●					BK ¹		0.331	0.197	7.48	10.15	13.39	50.00	15.74	17.66	19.31	25.14	21	37
120°	460.368	●	BA						0.037	0.026	0.09	0.13	0.17	0.63	0.20	0.22	0.24	0.32	26	41
	460.408	●	BA						0.047	0.033	0.15	0.20	0.27	1.00	0.31	0.35	0.39	0.50	27	43
	460.488	●	BA						0.059	0.039	0.24	0.32	0.43	1.60	0.50	0.57	0.62	0.80	28	46
	460.528	●	BA						0.065	0.047	0.30	0.41	0.54	2.00	0.63	0.71	0.77	1.01	28	47
	460.608	●	BA						0.083	0.055	0.47	0.64	0.84	3.15	0.99	1.11	1.22	1.58	29	50
	460.648	●		BC					0.096	0.063	0.60	0.81	1.07	4.00	1.26	1.41	1.55	2.01	30	52
	460.728	●			BE				0.122	0.075	0.94	1.28	1.69	6.30	1.98	2.23	2.43	3.17	31	54
	460.748	●			BE				0.130	0.075	1.06	1.44	1.90	7.10	2.24	2.51	2.74	3.57	31	55
	460.768	●			BE				0.138	0.075	1.20	1.62	2.14	8.00	2.52	2.83	3.09	4.02	31	56
	460.808	●			BE				0.150	0.095	1.50	2.03	2.68	10.00	3.15	3.53	3.86	5.03	32	56
	460.848	●			BE				0.165	0.107	1.87	2.54	3.35	12.50	3.94	4.42	4.83	6.29	32	57
	460.888	●				BG			0.181	0.122	2.39	3.25	4.28	16.00	5.04	5.65	6.18	8.05	33	58
	460.968	●				BG			0.232	0.161	3.74	5.07	6.69	25.00	7.87	8.83	9.66	12.57	33	59
	461.048	● ¹					BK ¹		0.300	0.193	5.98	8.12	10.71	40.00	12.60	14.13	15.45	20.11	34	60

¹ Material PP (mat. no. 53).
Also available in metric thread.

Conversion formula for this series: $\dot{V}_2 = \dot{V}_1 \cdot \left(\frac{p_2}{p_1}\right)^{0.4}$
(≤ 10 bar)

Ordering Type + Material no. + Connection = Ordering no.
example: 460.326 + 5E + CB = 460.326.5E.BA



Assembly accessories can be found in Chapter 12 "Accessories".

➤ Axial-flow full cone nozzles Series 490/491

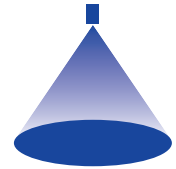

Features:

- Extremely uniform liquid distribution
- Very stable spray angle
- Non clogging due to large free cross sections

Applications:

- Cleaning and washing processes
- Surface spraying
- Chemical process engineering
- Foam control

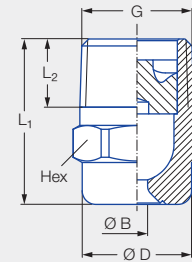

Figure 1

Series 490/491

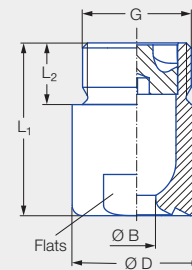

Figure 2

Connection	Figure	G	Dimensions [in]				Weight [lb] (brass)
			L ₁	L ₂	Ø D	Hex (mm)	
BA	1	1/8 NPT	0.71	0.26	0.39	11	0.03
BC	1	1/4 NPT	0.87	0.39	0.51	14	0.04
BE	1	3/8 NPT	0.96	0.39	0.63	17	0.07
BE	1	3/8 NPT	1.18	0.39	0.63	17	0.11
BG	1	1/2 NPT	1.28	0.51	0.83	22	0.13
BG	1	1/2 NPT	1.65	0.51	0.83	22	0.19
BK	2	3/4 NPT	1.65	0.59	1.26	27	0.42
BM	2	1 NPT	2.20	0.67	1.57	36	0.77

Spray angle	Ordering number								Bore diameter B [in]	Narrowest free cross sections Ø [in]	V̇ water [gal/min]								Spray diameter D [in] (at p = 30 psi)		
	Type	Mat. no.		Connection							p [psi]								H = 10 [in]	H = 20 [in]	
		1Y	30	Stainless steel 316L	Brass	1/8 NPT	1/4 NPT	3/8 NPT			1/2 NPT	3/4 NPT	1 NPT	7	15	30	Liters per min. 2 bar	45			75
45°	490.403	●	●	BA						0.049	0.049	0.15	0.20	0.27	1.00	0.31	0.39	0.43	0.50	8	16
	490.523	●	●	BA						0.067	0.067	0.30	0.41	0.54	2.00	0.63	0.77	0.87	1.01	8	16
	490.603	●	●		BC	BE ¹				0.079	0.079	0.47	0.64	0.84	3.15	0.99	1.22	1.37	1.58	8	16
	490.643	●	●		BC	BE ¹				0.096	0.096	0.60	0.81	1.07	4.00	1.26	1.55	1.73	2.01	8	16
	490.683		●			BE				0.100	0.100	0.75	1.01	1.34	5.00	1.57	1.93	2.17	2.51	8	16
	490.703		●			BE				0.104	0.104	0.84	1.14	1.50	5.60	1.76	2.16	2.43	2.82	8	17
	490.723	●	●			BE				0.112	0.112	0.94	1.28	1.69	6.30	1.98	2.43	2.73	3.17	8	17
	490.783		●				BG			0.136	0.136	1.35	1.83	2.41	9.00	2.83	3.48	3.90	4.53	8	17
	490.843		●				BG			0.150	0.150	1.87	2.54	3.35	12.50	3.94	4.83	5.42	6.29	9	17

¹ Only available in material 30.



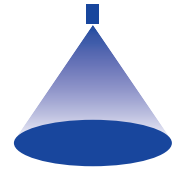

Spray angle	Ordering number										Bore diameter B [in]	Narrowest free cross sections Ø [in]	V̇ water [gal/min]								Spray diameter D [in] (at p = 30 psi)	
	Type	Mat. no.		Connection									p [psi]								H = 10 [in]	H = 20 [in]
		1Y	30	1/8 NPT	1/4 NPT	3/8 NPT	1/2 NPT	3/4 NPT	1 NPT	7			15	30	Liters per min. 2 bar	45	75	100	145			
		Stainless steel 316L	Brass																			
60°	490.404	●	●	BA							0.045	0.045	0.15	0.20	0.27	1.00	0.31	0.39	0.43	0.50	10	20
	490.444	●		BA							0.049	0.049	0.19	0.25	0.33	1.25	0.39	0.48	0.54	0.63	10	20
	490.484	●	●	BA							0.057	0.057	0.24	0.32	0.43	1.60	0.50	0.62	0.69	0.80	10	20
	490.524	●	●	BA							0.063	0.063	0.30	0.41	0.54	2.00	0.63	0.77	0.87	1.01	11	21
	490.564	●	●	BA							0.071	0.071	0.37	0.51	0.67	2.50	0.79	0.97	1.08	1.26	11	21
	490.604	●	●	BA	BC	BE					0.081	0.081	0.47	0.64	0.84	3.15	0.99	1.22	1.37	1.58	11	21
	490.644	●	●		BC	BE					0.091	0.091	0.60	0.81	1.07	4.00	1.26	1.55	1.73	2.01	11	21
	490.684	●	●		BC	BE					0.102	0.102	0.75	1.01	1.34	5.00	1.57	1.93	2.17	2.51	11	22
	490.724	●	●		BC	BE					0.116	0.110	0.94	1.28	1.69	6.30	1.98	2.43	2.73	3.17	11	22
	490.764	●	●			BE					0.128	0.128	1.20	1.62	2.14	8.00	2.52	3.09	3.47	4.02	11	22
	490.804	●	●			BE					0.146	0.146	1.50	2.03	2.68	10.00	3.15	3.86	4.33	5.03	11	22
	490.844	●	●				BG				0.159	0.159	1.87	2.54	3.35	12.50	3.94	4.83	5.42	6.29	11	22
	490.884	●	●				BG				0.183	0.183	2.39	3.25	4.28	16.00	5.04	6.18	6.93	8.05	12	23
	490.924	●	●					BK			0.205	0.205	2.99	4.06	5.36	20.00	6.30	7.73	8.67	10.06	12	23
	490.964	●	●					BK			0.228	0.228	3.74	5.07	6.69	25.00	7.87	9.66	10.83	12.57	12	23
	491.044	●	●						BM		0.285	0.285	5.98	8.12	10.71	40.00	12.60	15.45	17.34	20.11	12	24
491.084	●	●						BM		0.320	0.320	7.48	10.15	13.39	50.00	15.74	19.31	21.67	25.14	12	24	
90°	490.406	●	●	BA						0.047	0.047	0.15	0.20	0.27	1.00	0.31	0.39	0.43	0.50	19	35	
	490.446		●	BA						0.051	0.051	0.19	0.25	0.33	1.25	0.39	0.48	0.54	0.63	19	35	
	490.486	●	●	BA						0.057	0.057	0.24	0.32	0.43	1.60	0.50	0.62	0.69	0.80	20	35	
	490.526	●	●	BA						0.067	0.061	0.30	0.41	0.54	2.00	0.63	0.77	0.87	1.01	20	36	
	490.566	●	●	BA						0.075	0.075	0.37	0.51	0.67	2.50	0.79	0.97	1.08	1.26	20	36	
	490.606	●	●	BA		BE				0.083	0.081	0.47	0.64	0.84	3.15	0.99	1.22	1.37	1.58	20	37	
	490.646	●	●		BC	BE				0.094	0.094	0.60	0.81	1.07	4.00	1.26	1.55	1.73	2.01	20	37	
	490.686	●	●		BC	BE				0.106	0.106	0.75	1.01	1.34	5.00	1.57	1.93	2.17	2.51	20	38	
	490.726	●	●		BC	BE				0.126	0.110	0.94	1.28	1.69	6.30	1.98	2.43	2.73	3.17	21	38	
	490.746	●	●			BE				0.124	0.124	1.06	1.44	1.90	7.10	2.24	2.74	3.08	3.57	21	39	
	490.766	●	●			BE				0.134	0.134	1.20	1.62	2.14	8.00	2.52	3.09	3.47	4.02	21	39	
	490.806	●	●			BE				0.154	0.154	1.50	2.03	2.68	10.00	3.15	3.86	4.33	5.03	22	39	
	490.846	●	●			BE				0.183	0.157	1.87	2.54	3.35	12.50	3.94	4.83	5.42	6.29	22	39	
	490.886	●	●				BG			0.215	0.177	2.39	3.25	4.28	16.00	5.04	6.18	6.93	8.05	22	40	
	490.926	●	●				BG			0.232	0.177	2.99	4.06	5.36	20.00	6.30	7.73	8.67	10.06	22	40	
	490.966	●	●				BG			0.258	0.191	3.74	5.07	6.69	25.00	7.87	9.66	10.83	12.57	22	40	
491.006	●	●					BK		0.297	0.217	4.78	6.31	8.32	31.50	9.79	12.01	13.73	15.84	22	41		
491.046	●	●					BK		0.339	0.260	5.98	8.12	10.71	40.00	12.60	15.45	17.34	20.11	22	41		
491.086	●	●						BM	0.372	0.285	7.48	10.15	13.39	50.00	15.74	19.31	21.67	25.14	22	41		
491.126	●	●						BM	0.409	0.315	9.42	12.78	16.87	63.00	19.84	24.34	27.30	31.68	22	41		
491.146	●							BM	0.433	0.295	10.62	14.41	19.01	71.00	22.36	27.43	30.77	35.70	22	41		
120°	490.368	●	●	BA						0.033	0.026	0.09	0.13	0.17	0.63	0.20	0.24	0.27	0.32	28	49	
	490.408	●	●	BA						0.047	0.047	0.15	0.20	0.27	1.00	0.31	0.39	0.43	0.50	28	50	
	490.448	●	●	BA						0.051	0.051	0.19	0.25	0.33	1.25	0.39	0.48	0.54	0.63	29	50	
	490.488	●	●	BA						0.057	0.057	0.24	0.32	0.43	1.60	0.50	0.62	0.69	0.80	30	51	
	490.528	●	●	BA						0.067	0.067	0.30	0.41	0.54	2.00	0.63	0.77	0.87	1.01	31	52	
	490.568	●	●	BA						0.075	0.075	0.37	0.51	0.67	2.50	0.79	0.97	1.08	1.26	31	53	



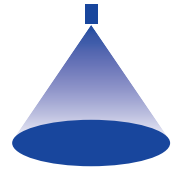

Spray angle	Ordering number										Bore diameter B [in]	Narrowest free cross sections Ø [in]	V̇ water [gal/min]								Spray diameter D [in] (at p = 30 psi)	
	Type	Mat. no.		Connection									p [psi]									
		1Y	30	1/8 NPT	1/4 NPT	3/8 NPT	1/2 NPT	3/4 NPT	1 NPT	7			15	30	Liters per min. 2 bar	45	75	100	145	H = 10 [in]		
		Stainless steel 316L	Brass																			
120°	490.608	●	●	BA							0.083	0.081	0.48	0.63	0.83	3.15	0.98	1.20	1.37	1.58	32	54
	490.648	●	●		BC	BE					0.094	0.094	0.61	0.80	1.06	4.00	1.24	1.52	1.74	2.01	33	55
	490.688	●	●		BC	BE					0.108	0.108	0.76	1.00	1.32	5.00	1.55	1.90	2.18	2.51	33	56
	490.728	●	●		BC	BE					0.126	0.110	0.96	1.26	1.66	6.30	1.96	2.40	2.75	3.17	34	58
	490.748	●	●			BE					0.126	0.126	1.08	1.42	1.88	7.10	2.21	2.71	3.10	3.57	34	59
	490.768	●	●			BE					0.136	0.136	1.21	1.60	2.11	8.00	2.49	3.05	3.49	4.02	35	60
	490.808	●	●			BE					0.154	0.154	1.52	2.00	2.64	10.00	3.11	3.81	4.36	5.03	35	62
	490.848	●	●			BE					0.185	0.157	1.90	2.50	3.30	12.50	3.88	4.76	5.45	6.29	36	64
	490.888	●	●				BG				0.201	0.177	2.43	3.20	4.23	16.00	4.97	6.10	6.98	8.05	36	66
	490.928	●	●				BG				0.228	0.187	3.04	4.00	5.28	20.00	6.21	7.62	8.72	10.06	37	67
	490.968	●	●				BG	BK			0.262	0.191	3.79	5.01	6.60	25.00	7.77	9.53	10.90	12.57	37	67
	491.048	●	●					BK			0.358	0.230	6.07	8.01	10.57	40.00	12.43	15.25	17.44	20.11	37	68
	491.128	●	●						BM		0.425	0.305	9.56	12.61	16.64	63.00	19.57	24.01	27.47	31.68	37	69
	491.148	●							BM		0.449	0.301	10.77	14.22	18.76	71.00	22.06	27.06	30.96	35.70	37	69

Conversion formula for this series: $\dot{V}_2 = \dot{V}_1 \cdot \left(\frac{p_2}{p_1}\right)^{0.4}$
 (≤ 10 bar)

Ordering Type + Material no. + Connection = Ordering no.
 example: 490.608 + 1Y + BA = 490.608.1Y.BA

 Assembly accessories can be found in Chapter 12 "Accessories".

➤ Axial-flow full cone nozzles Series 468

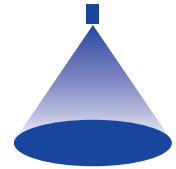

Features:

- Extremely uniform liquid distribution
- Assembly with retaining nut

Applications:

- Surface spraying
- Chemical process engineering
- Cleaning and washing processes
- Water treatment



Series 468

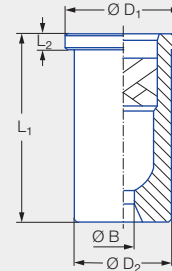

Connection	Dimensions [in]			Weight [lb] (brass)
	L ₂	Ø D ₁	Ø D ₂	
Assembly with retaining nut 3/8 BSPP	0.08	0.58	0.50	0.04

Spray angle	Ordering number				Bore diameter B [in]	Narrowest free cross sections Ø [in]	L ₁ [in]	V̇ water [gal/min]						Spray diameter D [mm] (at p = 30 psi)		
	Type	Material number						p [psi]						 H = 10 [in] H = 20 [in]		
		17 ¹	30	5E				7	15	30	Liters per min. 2 bar	45	75			145
60°	468.604	●	●		0.08	0.06	0.71	0.47	0.64	0.84	3.15	0.99	1.22	1.58	11	22
	468.644		●	●	0.09	0.07	0.96	0.60	0.81	1.07	4.00	1.26	1.55	2.01	11	22
	468.684		●		0.10	0.08	0.96	0.75	1.01	1.34	5.00	1.57	1.93	2.51	12	23
	468.724	●	●		0.11	0.08	0.96	0.94	1.28	1.69	6.30	1.98	2.43	3.17	12	23
90°	468.526	●	●	●	0.06	0.05	0.71	0.30	0.41	0.54	2.00	0.62	0.77	1.01	18	31
	468.846	●	●		0.16	0.13	0.96	1.87	2.54	3.35	12.50	3.94	4.83	6.29	20	36
120°	468.368		●		0.04	0.028	0.71	0.09	0.13	0.17	0.63	0.20	0.24	0.32	29	69
	468.408	●	●		0.05	0.033	0.71	0.15	0.20	0.27	1.00	0.31	0.39	0.50	29	69
	468.488	●	●		0.060	0.04	0.71	0.24	0.32	0.43	1.60	0.50	0.62	0.80	29	69
	468.528	●	●		0.065	0.05	0.71	0.30	0.40	0.54	2.00	0.63	0.77	1.01	29	69

¹ We reserve the right to supply material 316Ti or 316L under material no. 17.

Also available in metric thread.

Bases and Caps for Mounting

Inlet NPT Male	Outlet Male	Part No.	Standard Materials: 17 316 SS 30 Brass
1/4"	11/16 x 16	065. 215. XX. 10	
3/8"	11/16 x 16	065. 211. XX. 10	
1/4"	3/8 BSPP	065. 215. XX. 11	
3/8"	3/8 BSPP	065. 215. XX. 12	
Caps			Other materials available.
To fit 11/16x16		069. 000. XX. 00	
To fit 3/8 BSPP		065. 200. XX. 00	

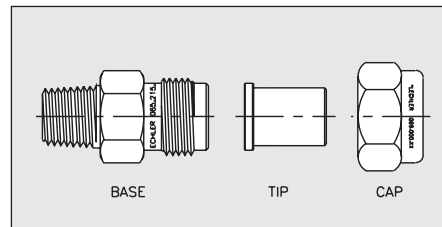

Conversion formula for this series: $\dot{V}_2 = \dot{V}_1 \cdot \left(\frac{p_2}{p_1}\right)^{0.4}$
(≤ 10 bar)

Ordering Type + Material no. = Ordering no.
example: 468.604 + 17 = 468.604.17

 Assembly accessories can be found in Chapter 12 "Accessories".

Full cone nozzle Injector narrow angle nozzle Series 452

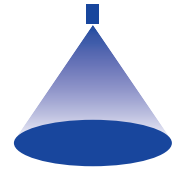

Features:

- Narrow spray angle
- High impact

Applications:

- Cleaning and washing processes
- Surface spraying



Series 452

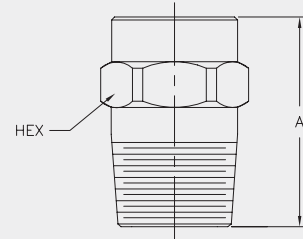

G (Male NPT)	Dimensions [in]		Weight [lb.]
	A	Hex (mm)	
1/4	1.81	18	0.16
3/8	2.31	24	0.20

Spray angle	Ordering number				V̇ water [gal/min]										Spray diameter D [in] (at p = 30 psi)
	Type	Material No.		Connection		P [psi]									
		16	30	1/4 NPT	3/8 NPT	10	20	30	Liters per min.	40	60	80	100		
		303 stainless steel	Brass						2 bar						
15°	452.661	●	●	BC	-	0.74	0.98	1.15	4.30	1.29	1.52	1.70	1.86	2	
	452.791	●	●	BC	-	1.59	2.09	2.46	9.20	2.76	3.25	3.65	3.99	2	
	452.881	●	●	-	BE	2.64	3.48	4.10	15.30	4.60	5.41	6.06	6.63	2	
30°	452.442	●	●	BC	-	0.22	0.29	0.34	1.27	0.38	0.45	0.50	0.55	5	
	452.542	●	●	BC	-	0.37	0.49	0.58	2.15	0.65	0.76	0.85	0.93	5	
	452.502	●	●	BC	-	0.55	0.72	0.85	3.16	0.95	1.12	1.25	1.37	5	
	452.672	●	●	-	BE	0.83	1.10	1.29	4.83	1.45	1.71	1.91	2.09	5	

Conversion formula for this series: $\dot{V}_2 = \dot{V}_1 \cdot \left(\frac{p_2}{p_1}\right)^{0.4}$
(≤ 10 bar)

Ordering Type + Material no. + Connection = Ordering no.
example: 452.661 + 16 + BC = 452.661.16.BC

➤ Axial-flow full cone nozzles Series 405

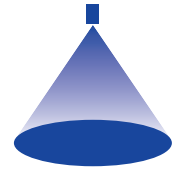

Features:

- Extremely uniform liquid distribution

Applications:

- Surface spraying
- Chemical process engineering
- Cleaning and washing processes
- Water treatment



Series 405

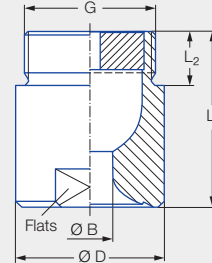

Connection	G	Dimensions [in]				Weight [lb] (brass)
		L ₁	L ₂	Ø D	Flats (mm)	
BP	1 1/4 NPT	1.97	0.75	1.93	41	1.1
BR	1 1/2 NPT	2.36	0.75	2.32	50	2.0
BV	2 NPT	3.07	0.94	2.68	60	3.5

Spray angle	Ordering number						Bore diameter B [in]	Narrowest free cross sections Ø [in]	V̇ water [gal/min]							Spray diameter D [in] (at p = 30 psi)	
	Type	Mat. no.		Connection					p [psi]							 H = 20 [in] H = 40 [in]	
		1Y	30	1 1/4 NPT	1 1/2 NPT	2 NPT											
		Stainless steel 316L	Brass						5	7	15	30	Liters per min. 2 bar	45	60		
60°	405.204	●	●	BP			0.44	0.23	13.08	14.96	20.29	26.78	100	31.49	35.33	24	45
	405.284	●	●		BR		0.56	0.28	20.92	23.94	32.47	42.84	160	50.38	56.53	25	48
	405.324	●	●			BV	0.65	0.30	26.15	29.92	40.58	53.55	200	62.98	70.66	26	49
	405.364	●	●			BV	0.72	0.33	32.69	37.40	50.73	66.94	250	78.72	88.32	26	49
	405.404	●				BV	0.79	0.28	41.19	47.12	63.92	84.34	315	99.19	111.29	26	49
90°	405.206	●	●	BP			0.47	0.20	13.08	14.96	20.29	26.78	100	31.49	35.33	44	83
	405.286	●	●		BR		0.60	0.24	20.92	23.94	32.47	42.84	160	50.38	56.53	44	83
	405.326	●				BV	0.68	0.30	26.15	29.92	40.58	53.55	200	62.98	70.66	44	83
	405.366	●				BV	0.77	0.34	32.69	37.40	50.73	66.94	250	78.72	88.32	44	83
	405.406	●	●			BV	0.87	0.37	41.19	47.12	63.92	84.34	315	99.19	111.29	44	83
120°	405.208	●	●	BP			0.50	0.20	13.08	14.96	20.29	26.78	100	31.49	35.33	73	120
	405.288	●	●		BR		0.63	0.26	20.92	23.94	32.47	42.84	160	50.38	56.53	75	124
	405.328	●				BV	0.70	0.31	26.15	29.92	40.58	53.55	200	62.98	70.66	75	126
	405.368	●	●			BV	0.79	0.35	32.69	37.40	50.73	66.94	250	78.72	88.32	75	126
	405.408	●	●			BV	0.88	0.36	41.19	47.12	63.92	84.34	315	99.19	111.29	75	126

Also available in BSPP metric thread.

Conversion formula for this series: $\dot{V}_2 = \dot{V}_1 \cdot \left(\frac{p_2}{p_1}\right)^{0.4}$
(≤ 10 bar)

Ordering Type + Material no. + Connection = Ordering no.
example: 405.204 + 1Y + BP = 405.204.1Y.BP

 Assembly accessories can be found in Chapter 12 "Accessories".

Full cone nozzles Axial-flow CenterJet™ Series 459

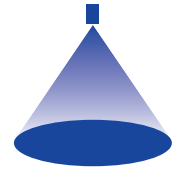

Features:

- Turbine-style vane for uniform atomization and distribution

Applications:

- Surface spraying
- Quench cooling
- Fire suppression
- Chemical processing



Series 459

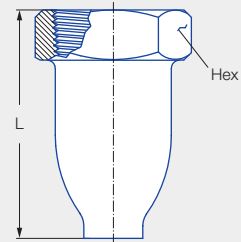

Dimensions (in)			Weight (lb)
Inlet (Female NPT)	L	Hex (mm)	
1-1/2	4.31	56	1.8
2	5.45	70	2.4
2-1/2	6.00	83	4.2
3	6.89	99	6.0

	Spray Angle in degrees at 40 psi (* = 15 psi)	Ordering number						Bore diameter (in)	V̇ water [gal/min]								
		Type	Mat. no.	Connection					P [psi]								
				17 ¹ 316SS	1½ NPT	2 NPT	2½ NPT		3 NPT	5	10	15	20	Liters per min. 2 bar	40	60	80
Standard angle	62	459.244	●	BS	-	-	-	.500	16.21	21.39	25.16	28.23	124	37.25	43.81	49.15	53.74
	62	459.284	●	BS	-	-	-	.625	21.58	28.47	33.48	37.56	165	49.57	58.29	65.40	71.51
	70	459.355	●	BS	-	-	-	.687	30.47	40.20	47.28	53.05	233	69.99	82.32	92.36	100.98
	84	459.356	●	BS	-	-	-	.687	30.47	40.20	47.28	53.05	233	69.99	82.32	92.36	100.98
	43	459.343	●	-	BW	-	-	.500	29.03	38.30	45.05	50.54	222	66.69	78.43	88.00	96.21
	80*	459.365	●	-	BW	-	-	.656	30.64	41.75	49.11	55.09	242	72.70	85.50	95.93	104.88
	66	459.415	●	-	BW	-	-	.796	44.33	58.49	68.79	77.18	339	101.84	119.77	134.37	146.92
	68	459.455	●	-	BW	-	-	.906	56.75	74.88	88.07	98.81	434	130.38	153.33	172.03	188.09
	83	459.475	●	-	-	BZ	-	.910	62.11	81.96	96.39	108.14	475	142.69	167.82	188.28	205.86
Wide angle	67	459.515	●	-	-	BZ	-	1.06	78.85	104.04	122.36	137.28	603	181.14	213.04	239.02	261.34
	57	459.584	●	-	-	-	MB	1.31	120.95	159.60	187.70	210.59	925	277.87	326.80	366.66	400.89
	120	459.238	●	BS	-	-	-	.562	16.21	21.39	25.16	28.23	124	37.25	43.81	49.15	53.74
	98	459.266	●	BS	-	-	-	.500	15.30	20.19	23.74	26.64	117	35.15	41.34	46.38	50.71
	94	459.286	●	BS	-	-	-	.625	21.58	28.47	33.48	37.56	165	49.57	58.29	65.40	71.51
	120	459.288	●	BS	-	-	-	.625	21.18	27.95	32.87	36.88	162	48.67	57.23	64.21	70.21
	120	459.348	●	BS	-	-	-	.781	29.55	38.99	45.86	51.45	226	67.89	79.85	89.58	97.95
	118	459.378	●	-	BW	-	-	.781	35.70	47.10	55.40	62.15	273	82.01	96.45	108.21	118.32
	*99	459.386	●	-	BW	-	-	.796	40.67	53.66	63.11	70.80	311	93.43	109.88	123.28	134.79
	118	459.408	●	-	BW	-	-	.937	43.41	57.28	67.37	75.58	332	99.73	117.30	131.60	143.89
	119	459.488	●	-	-	BZ	-	1.03	68.13	89.89	105.72	118.61	521	156.51	184.07	206.52	225.80
*86	459.496	●	-	-	BZ	-	0.98	71.00	93.69	110.18	123.62	543	163.12	191.84	215.24	235.33	
*90	459.575	●	-	-	-	MB	1.31	122.65	161.84	190.34	213.55	938	281.78	331.39	371.81	406.52	
120	459.608	●	-	-	-	MB	1.43	164.10	216.53	254.66	285.72	1255	377.01	443.39	497.46	543.91	

¹ We reserve the right to supply material 316Ti or 316L under material no. 17.

* Nozzles are manufactured to spray performance, not orifice diameter.

Conversion formula for this series: $\dot{V}_2 = \dot{V}_1 \cdot \left(\frac{p_2}{p_1}\right)^{0.4}$
(≤ 10 bar)

Ordering example: Type 459.455 + Material no. 17 + Conn. BW = Ordering no. 459.455.17.BW

Notice:

This product line is also available in larger capacities with inlets up to 6" in size.

Please contact Lechler if you have an application requiring a larger size.

➤ Axial-flow full cone nozzles Series 403

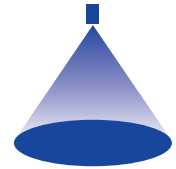

Features:

- Extremely uniform liquid distribution

Applications:

- Surface spraying
- Spraying over packings
- Chemical process engineering
- Cleaning and washing processes
- Cooling

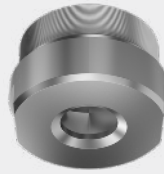

Series 403

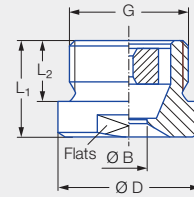

90° version

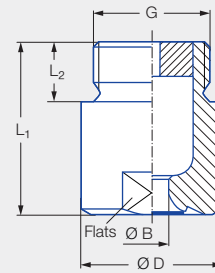

120° version

90° version

Type	G	Dimensions [in]				Weight [lb]
		L ₁	L ₂	Ø D	Flats (mm)	
403.446/403.486	2 1/2 NPT	2.05	1.06	3.27	75	2.87
403.526	3 NPT	2.36	1.18	3.86	85	4.41
403.606	3 1/2 NPT	2.76	1.26	4.65	105	7.94

120° version

Type	G	Dimensions [in]				Weight [lb]
		L ₁	L ₂	Ø D	Flats (mm)	
403.448/403.488	2 1/2 NPT	4.88	1.06	3.27	75	7.05
403.528	3 NPT	6.02	1.18	3.86	85	11.91
403.608	3 1/2 NPT	6.14	1.26	4.65	105	18.30
403.628	4 NPT	6.50	1.42	5.04	110	21.16

Spray angle	Ordering number		Bore diameter B [in]	Narrowest free cross sections Ø [in]	V̇ water [gal/min]								Spray diameter D [in] (at p = 30 psi)	
	Type	Mat. no.			p [psi]								 H = 20 [in] H = 40 [in]	
		1Y												
		Stainless steel 316L			5	7	15	30	Liters per min. 2 bar	45	60	75		
90°	403.446	●	5.6	2.7	52.30	59.84	81.17	107.10	400	125.96	141.32	154.51	39	70
	403.486	●	6.6	2.7	65.38	74.80	101.46	133.88	500	157.45	176.65	193.14	39	70
	403.526	●	7.2	3.1	82.38	94.25	127.84	168.68	630	198.38	222.58	243.36	39	70
	403.606	●	9.0	3.4	130.76	149.60	202.92	267.75	1,000	314.90	353.30	386.28	39	70
120°	403.448	●	5.7	2.2	52.30	59.84	81.17	107.10	400	125.96	141.32	154.51	67	115
	403.488	●	6.6	2.5	65.38	74.80	101.46	133.88	500	157.45	176.65	193.14	67	115
	403.528	●	7.2	3.4	82.38	94.25	127.84	168.68	630	198.38	222.58	243.36	67	115
	403.608	●	9.4	2.7	130.76	149.60	202.92	267.75	1,000	314.90	353.30	386.28	67	115
	403.628	●	10.1	3.4	163.45	187.00	253.65	324.69	1,250	393.62	441.62	482.86	67	115

Also available in BSPP metric thread.

Conversion formula for this series: $\dot{V}_2 = \dot{V}_1 \cdot \left(\frac{p_2}{p_1}\right)^{0.4}$
(≤ 10 bar)

Ordering Type + Material no. = Ordering no.
example: 403.446 + 1Y = 403.446.1Y



Assembly accessories can be found in Chapter 12 "Accessories".

➤ Axial-flow full cone nozzles Series 419 FreeFlow

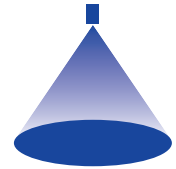

Features:

- Non clogging due to very large free cross sections
- Very stable spray angle
- Uniform liquid distribution

Applications:

- Cleaning and washing processes
- Dust control
- Absorption
- Distillation

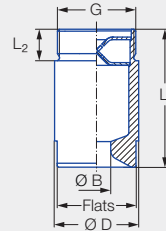

Figure 1

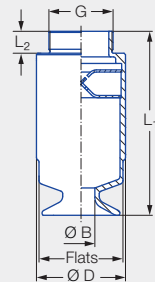



Figure 2

Series 419

Type	Connection	Figure	G	Dimensions [in]				Weight [lb]
				L ₁	L ₂	Ø D	Flats (mm)	
419.3xx	BV	1	2 NPT	4.13	0.94	2.52	60	2.6
419.4xx	BV	2	2 NPT	6.42	0.94	3.15	75	4.4
419.51x	BV	2	2 NPT	7.83	0.94	4.02	95	8.2
419.51x	BY	2	2 1/2 NPT	7.95	1.06	4.02	95	8.4
419.54x	BY	2	2 1/2 NPT	7.95	1.06	4.02	95	8.4
419.57x	BY	2	2 1/2 NPT	9.09	1.06	4.53	105	11.5
419.57x	MA	2	3 NPT	9.17	1.18	4.53	105	11.5
419.6xx	MA	2	3 NPT	9.92	1.18	4.80	115	11.9

Spray angle ¹	Ordering number				Bore diameter B [in]	Narrowest free cross sections Ø [in]	V water gal/min						Spray diameter D [in] (at p = 30 psi)		
	Type	Mat. no.	Connection				p [psi]								
			1Y	2 NPT			2 1/2 NPT	3 NPT	5	7	15	Liters per min. 1 bar			30
													Stainless steel 316L	2 NPT	
90°	419.366	●	BV			0.75	0.69	32.61	37.31	50.60	189	66.77	96.33	47	87
	419.396	●	BV			0.83	0.69	39.17	44.81	60.78	227	80.20	115.70	47	87
	419.446	●	BV			0.94	0.81	52.28	59.81	81.13	303	107.05	154.44	47	87
	419.486	●	BV			1.14	0.81	65.39	74.81	101.48	379	133.90	193.18	47	87
	419.516	●	BV	BY		1.15	0.95	78.50	89.81	121.83	455	160.70	231.92	47	87
	419.546	●		BY		1.30	0.95	92.82	106.20	144.05	538	190.08	274.22	47	87
	419.576	●		BY	MA	1.38	1.07	111.11	127.12	172.43	644	277.52	328.25	47	87
	419.606	●			MA	1.48	1.19	130.78	149.62	202.96	758	267.80	386.36	47	87
419.626	●			MA	1.69	1.19	163.39	186.93	253.56	947	334.57	482.69	47	87	
120°	419.368	●	BV			0.87	0.69	32.61	37.31	50.60	189	66.77	96.33	65	114
	419.398	●	BV			0.95	0.69	39.17	44.81	60.78	227	80.20	115.70	65	114
	419.448	●	BV			0.96	0.81	52.28	59.81	81.13	303	107.05	154.44	65	114
	419.488	●	BV			1.16	0.81	65.39	74.81	101.48	379	133.90	193.18	65	114
	419.518	●	BV	BY		1.15	0.95	78.50	89.81	121.83	455	160.70	231.92	65	114
	419.548	●		BY		1.34	0.95	92.82	106.20	144.05	538	190.08	274.22	65	114
	419.578	●		BY	MA	1.38	1.13	111.11	127.12	172.43	644	277.52	328.25	65	114
	419.608	●			MA	1.50	1.27	130.78	149.62	202.96	758	267.80	386.36	65	114
419.628	●			MA	1.71	1.27	163.39	186.93	253.56	947	334.57	482.69	65	114	

¹ Spray angle at 1 bar.

Also available in metric thread.

Conversion formula for this series: $\dot{V}_2 = \dot{V}_1 \cdot \left(\frac{p_2}{p_1}\right)^{0.4}$
(≤ 10 bar)

Ordering Type + Material no. + Connection = Ordering no.
example: 419.366 + 1Y + BV = 419.366.1Y.BV

 Assembly accessories can be found in Chapter 12 "Accessories".

➤ Axial-flow full cone nozzles Series 485

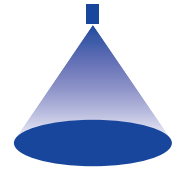

Features:

- One piece design
- Generates large droplets and even droplets at a wide a wide range of operating pressures

Applications:

- High volume surface spraying
- Cooling and quenching
- Fire protection
- Chemical processing and scrubbers



Series 485

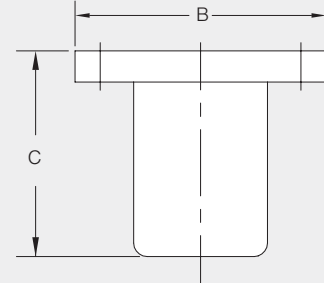

Inlet Flange Connection	Dimensions [in]		Weight [lb.]
	B	C	
4	9.00	6.13	19
5	10.00	8.38	42
6	11.00	10.56	54
8	13.47	12.25	98
10	16.00	17.00	140
12	19.00	20.00	200
16	23.50	22.00	330
18	25.00	28.75	450

Nozzle Inlet Flange Conn. (in)	Ordering no. Material number	Bore diameter [in]	Free Passage (In.)	V̇ water [gal/min]											Spray Angle in degrees at				
				p [psi]											3 psi	7 psi	15 psi		
				1	2	3	5	7	10	15	20	Liters per min. 2 bar	40	60					
	17 ¹ 316 SS																		
4	485.646.17.04	2.25	1.19	108	143	168	207	236	273	321	360	1581	475	558	77	80	82		
	485.656.17.04	2.50		126	167	196	241	276	318	374	420	1844	554	651	86	90	91		
	485.666.17.04	2.75		152	201	236	290	332	382	450	505	2218	666	783	88	92	94		
	485.676.17.04	3.00		169	223	263	323	369	426	501	562	2468	741	872	91	95	97		
5	485.676.17.05	2.75	.68	169	223	263	323	369	426	501	562	2468	741	872	82	92	92		
	485.686.17.05	2.84		181	239	282	346	395	456	536	602	2644	794	934	85	92	95		
	485.696.17.05	2.95		193	255	299	367	420	485	570	640	2811	844	993	86	93	95		
	485.706.17.05	3.15		214	282	332	407	466	537	632	709	3114	935	1100	88	94	98		
	485.716.17.05	3.32		243	321	377	463	529	611	718	806	3540	1063	1250	84	90	94		
	485.726.17.05	3.50		269	355	417	512	586	676	795	892	3918	1177	1384	86	92	97		
6	485.716.17.06	3.25	.97	243	321	377	463	529	611	718	803	3540	1063	1250	80	86	90		
	485.726.17.06	3.47		269	355	417	512	586	676	795	892	3918	1177	1384	82	88	94		
	485.736.17.06	3.62		295	389	458	562	642	741	872	978	4296	1290	1518	83	89	95		
	485.746.17.06	3.87		323	426	501	614	703	811	954	1070	4700	1412	1660	86	89	98		
	485.756.17.06	4.12		369	488	573	703	805	928	1092	1225	5381	1616	1901	87	94	96		
	485.766.17.06	4.62		400	527	620	761	870	1004	1181	1325	5820	1748	2056	88	94	98		
	485.736.17.08	3.5		311	410	482	591	677	780	918	1030	4524	1359	1598	63	70	70		
8	485.756.17.08	3.93	1.31	397	523	615	755	864	996	1172	1315	5776	1735	2040	80	87	90		
	485.776.17.08	4.43		475	627	737	904	1035	1193	1404	1575	6918	2078	2444	90	100	102		
	485.786.17.08	5.12		543	716	842	1034	1183	1364	1604	1800	7906	2375	2793	82	96	101		
	485.806.17.10	5.00		603	796	936	1149	1314	1516	1782	2000	8785	2639	3104	85	87	90		
10	485.826.17.10	5.56	1.75	739	975	1147	1407	1610	1857	2184	2450	10762	3233	3802	85	87	90		
	485.836.17.10	6.00		884	1166	1372	1683	1925	2220	2611	2930	12870	3866	4547	85	87	90		
	485.846.17.12	6.21		941	1242	1461	1792	2050	2364	2781	3120	13705	4117	4842	85	87	90		
12	485.856.17.12	6.59	2.06	1044	1377	1620	1987	2273	2622	3084	3460	15198	4565	5369	85	87	90		
	485.866.17.12	7.06		1207	1592	1873	2297	2628	3031	3565	4000	17570	5278	6207	85	87	90		
	485.876.17.12	7.40		1321	1744	2051	2516	2878	3319	3904	4380	19240	5780	6797	85	87	90		
	485.896.17.16	8.00		1554	2050	2411	2958	2958	3384	4590	5150	22622	6796	7992	85	87	90		
16	485.916.17.16	9.25	2.75	1985	2620	3081	3779	4324	4987	5865	6580	28904	8683	10212	85	87	90		
	485.936.17.18	10.7		2598	3428	4031	4945	5658	6525	7674	8610	37821	11361	13362	85	87	90		

* Nozzles are manufactured to spray performance, not orifice diameter

➤ Tangential-flow full cone nozzles stainless steel/brass version Series 422/423

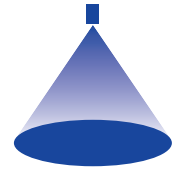

Features:

- Tangentially arranged supply of liquid
- Without swirl inserts
- Non-clogging
- Stable spray angle
- Uniform liquid distribution

Applications:

- Surface spraying
- Cooling
- Cleaning and washing processes
- Foam control

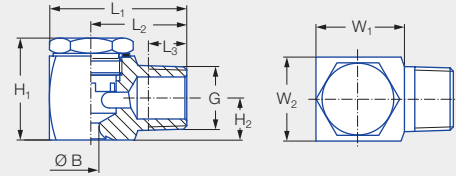
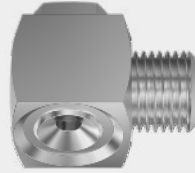

Figure 1

Series 422/423

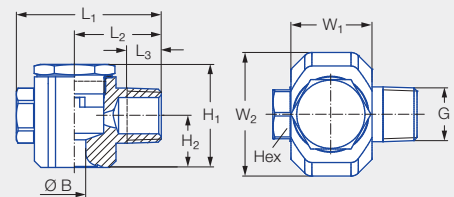
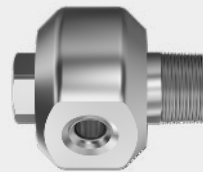

Figure 2

Connection	Figure	G	Dimensions [in]								Hex (mm)	Weight [lb] (stainless steel 316L)
			H ₁	H ₂	L ₁	L ₂	L ₃	W ₁	W ₂			
BC	1	1/4 NPT	0.83	0.31	1.10	0.79	0.38	0.61	0.61	-	0.1	
BE	1	3/8 NPT	1.05	0.43	1.42	0.98	0.40	0.91	0.91	-	0.22	
BG	2	1/2 NPT	1.57	0.79	2.20	1.32	0.52	1.26	1.26	19	0.82	
BK	2	3/4 NPT	2.24	0.93	2.58	1.52	0.57	1.57	1.57	27	1.83	
BM	2	1 NPT	2.60	1.07	3.35	1.91	0.66	2.17	2.17	36	3.49	

Spray angle	Ordering Number										Bore diameter [in]	Narrowest free cross sections Ø [in]	V̇ water gal/min							Spray diameter D [in] (at p = 30 psi)		
	Type	Material number		Connection						p [psi]							H = 10 [in]	H = 20 [in]				
		1Y	30	1/4 NPT	3/8 NPT	1/2 NPT	3/4 NPT	1 NPT	1-1/4 NPT	2 NPT			10	20	30	Liters per min.			80	100		
		316L SS	Brass													2					4	
30°	422.882	●					BE				0.193	0.193	2.48	3.51	4.30	16.00	4.96	6.08	7.02	7.85	6	15
	423.082	●					BK				0.323	0.323	7.76	10.97	13.43	50.00	15.51	19.00	21.94	24.53	6	15
	423.202	●							BP		0.472	0.472	15.51	21.94	26.87	100.00	31.03	38.00	43.88	49.06	6	15
60°	422.364	●		BC							0.045	0.043	0.09	0.13	0.16	0.60	0.19	0.23	0.26	0.29	10	20
	422.484	●		BC							0.071	0.071	0.25	0.35	0.43	1.60	0.50	0.61	0.70	0.78	10	20
	422.524	●			BE						0.079	0.079	0.31	0.44	0.54	2.00	0.62	0.76	0.88	0.98	10	20
	422.564	●			BE						0.089	0.089	0.39	0.55	0.67	2.50	0.78	0.95	1.10	1.23	10	20
	422.644	●	●		BE						0.118	0.118	0.62	0.88	1.07	4.00	1.24	1.52	1.76	1.96	10	20
	422.724	●			BE						0.142	0.142	0.98	1.38	1.69	6.30	1.95	2.39	2.76	3.09	10	20
	422.784	●				BG					0.163	0.163	1.40	1.97	2.42	9.00	2.79	3.42	3.95	4.42	10	20
	422.884	●				BG					0.252	0.252	2.48	3.51	4.30	16.00	4.96	6.08	7.02	7.85	15	25
	423.124	●					BK				0.441	0.441	9.77	13.82	16.93	63.00	19.55	23.94	27.65	30.91	15	25
	423.174	●						BM			0.500	0.500	13.19	18.65	22.84	85.00	26.37	32.30	37.30	41.70	15	25
	423.414	●							BV		0.969	0.969	51.97	73.50	90.00	335.00	103.95	127.31	147.00	164.30	15	25

Also available in metric thread.



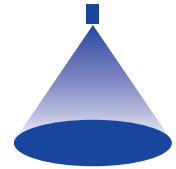

Spray angle	Ordering Number											Bore diameter [in]	Narrowest free cross sections Ø [in]									Spray diameter D [in] (at p = 30 psi)			
	Type	Material number		Connection										10	20	30	Liters per min. 2 bar	40	60	80	100	H =10 [in]	H =20 [in]		
		1Y	30	1/4 NPT	3/8 NPT	1/2 NPT	3/4 NPT	1 NPT	1-1/4 NPT	2 NPT	2-1/2 NPT													3 NPT	
		316L SS	Brass																						
90°	422.286	●	BC											0.027	0.027	0.04	0.05	0.07	0.25	0.08	0.09	0.11	0.12	20	35
	422.326	●	BC											0.033	0.031	0.06	0.09	0.11	0.40	0.12	0.15	0.18	0.20	20	35
	422.346	●	BC											0.037	0.035	0.08	0.11	0.13	0.50	0.16	0.19	0.22	0.25	20	35
	422.366	●	BC											0.043	0.043	0.09	0.13	0.16	0.60	0.19	0.23	0.26	0.29	20	35
	422.406	●	●	BC										0.059	0.057	0.16	0.22	0.27	1.00	0.31	0.38	0.44	0.49	20	35
	422.446	●	BC											0.065	0.063	0.20	0.29	0.35	1.30	0.40	0.49	0.57	0.64	20	35
	422.486	●	BC											0.075	0.071	0.25	0.35	0.43	1.60	0.50	0.61	0.70	0.78	20	35
	422.506	●	BC											0.079	0.079	0.28	0.39	0.48	1.80	0.56	0.68	0.79	0.88	20	36
	422.526	●	BC											0.083	0.083	0.31	0.44	0.54	2.00	0.62	0.76	0.88	0.98	20	36
	422.566	●	●	BC										0.091	0.087	0.39	0.55	0.67	2.50	0.78	0.95	1.10	1.23	20	36
	422.606	●	●		BE									0.102	0.099	0.49	0.69	0.85	3.15	0.98	1.20	1.38	1.55	20	36
	422.646	●	●		BE									0.118	0.114	0.62	0.88	1.07	4.00	1.24	1.52	1.76	1.96	20	36
	422.686	●	●		BE									0.130	0.126	0.78	1.10	1.34	5.00	1.55	1.90	2.20	2.45	20	36
	422.706	●			BE									0.138	0.134	0.87	1.23	1.50	5.60	1.74	2.13	2.46	2.75	20	38
	422.726	●	●		BE									0.146	0.142	0.98	1.38	1.69	6.30	1.95	2.39	2.76	3.09	20	38
	422.766	●			BE									0.163	0.161	1.24	1.76	2.15	8.00	2.48	3.04	3.51	3.92	20	38
	422.786	●			BE									0.173	0.169	1.40	1.97	2.42	9.00	2.79	3.42	3.95	4.42	20	38
	422.806	●	●		BE									0.183	0.181	1.55	2.19	2.69	10.00	3.10	3.80	4.39	4.91	20	38
	422.846	●	●		BE									0.205	0.201	1.94	2.74	3.36	12.50	3.88	4.75	5.49	6.13	20	38
	422.886	●	●		BE									0.229	0.225	2.48	3.51	4.30	16.00	4.96	6.08	7.02	7.85	20	40
	422.926	●				BG								0.287	0.287	3.10	4.39	5.37	20.00	6.21	7.60	8.78	9.81	20	40
	422.966	●				BG								0.315	0.315	3.88	5.49	6.72	25.00	7.76	9.50	10.97	12.27	20	40
	423.006	●				BG								0.343	0.343	4.81	6.80	8.33	31.00	9.62	11.78	13.60	15.21	20	40
	423.046	●					BK							0.426	0.402	6.21	8.78	10.75	40.00	12.41	15.20	17.55	19.62	20	40
	423.086	●					BK							0.449	0.433	7.76	10.97	13.43	50.00	15.51	19.00	21.94	24.53	20	40
	423.126	●					BK							0.500	0.485	9.77	13.82	16.93	63.00	19.55	23.94	27.65	30.91	20	40
	423.146	●						BM						0.552	0.532	11.02	15.58	19.07	71.00	22.03	26.98	31.16	34.83	20	40
	423.206	●						BM						0.670	0.630	15.51	21.94	26.87	100.00	31.03	38.00	43.88	49.06	20	40
	423.286	●							BP					0.748	0.748	24.82	35.11	42.98	160.00	49.63	60.79	70.19	78.48	20	40
	423.406	●								BV				0.965	0.965	48.87	69.11	84.63	315.00	97.72	119.68	138.19	154.50	20	40
	423.486	●								BY				1.240	1.240	77.57	109.70	134.33	500.00	155.11	189.97	219.35	245.25	20	40
	423.526	●								MA				1.398	1.398	97.74	138.23	169.25	630.00	195.43	239.36	276.39	309.01	20	40

Also available in metric thread.



Conversion formula for this series: $\dot{V}_2 = \dot{V}_1 \cdot \sqrt{\frac{P_2}{P_1}}$

Ordering Type + Material no. + Connection = Ordering no.
example: 422.488 + 30 + CC = 422.488.30.CC



Assembly accessories can be found in Chapter 12 "Accessories".

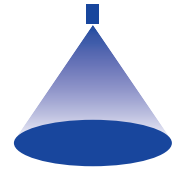

Spray angle	Ordering Number											Bore diameter [in]	Narrowest free cross sections Ø [in]	V̇ water [gal/min]								Spray diameter D [in] (at p = 30 psi)		
	Type	Material number		Connection										p [psi]								H =10 [in]	H =20 [in]	
		1Y	30	1/4 NPT	3/8 NPT	1/2 NPT	3/4 NPT	1 NPT	1-1/4 NPT	2 NPT	2-1/2 NPT			Liters per min.	2 bar	40	60	80	100					
																				316L SS	Brass			10
120°	422.368	●		BC									0.047	0.047	0.09	0.13	0.16	0.60	0.19	0.23	0.26	0.29	26	47
	422.408	●		BC									0.059	0.057	0.16	0.22	0.27	1.00	0.31	0.38	0.44	0.49	26	47
	422.448	●		BC									0.065	0.063	0.19	0.27	0.34	1.25	0.39	0.47	0.55	0.61	26	47
	422.488	●	●	BC									0.075	0.071	0.25	0.35	0.43	1.60	0.50	0.61	0.70	0.78	26	47
	422.508	●		BC									0.079	0.075	0.28	0.39	0.48	1.80	0.56	0.68	0.79	0.88	26	47
	422.528	●		BC									0.083	0.079	0.31	0.44	0.54	2.00	0.62	0.76	0.88	0.98	26	47
	422.568	●	●	BC									0.091	0.087	0.39	0.55	0.67	2.50	0.78	0.95	1.10	1.23	26	47
	422.608	●	●		BE								0.102	0.098	0.49	0.69	0.85	3.15	0.98	1.20	1.38	1.55	26	47
	422.648	●			BE								0.118	0.114	0.62	0.88	1.07	4.00	1.24	1.52	1.76	1.96	26	47
	422.688	●			BE								0.130	0.126	0.78	1.10	1.34	5.00	1.55	1.90	2.19	2.45	26	47
	422.708	●			BE								0.138	0.134	0.87	1.23	1.50	5.60	1.74	2.13	2.46	2.75	26	47
	422.728	●	●		BE								0.146	0.142	0.98	1.38	1.69	6.30	1.95	2.39	2.76	3.09	30	55
	422.768	●			BE								0.163	0.161	1.24	1.76	2.15	8.00	2.48	3.04	3.51	3.92	30	55
	422.788	●			BE								0.173	0.169	1.40	1.97	2.42	9.00	2.79	3.42	3.95	4.42	30	55
	422.808	●			BE								0.183	0.181	1.55	2.19	2.69	10.00	3.10	3.80	4.39	4.91	33	58
	422.848	●	●		BE								0.205	0.201	1.94	2.74	3.36	12.50	3.88	4.75	5.49	6.13	33	58
	422.888	●	●		BE								0.228	0.224	2.48	3.51	4.30	16.00	4.96	6.08	7.02	7.85	33	58
	422.928	●				BG							0.287	0.287	3.10	4.39	5.37	20.00	6.21	7.60	8.78	9.81	35	63
	422.968	●	●			BG							0.315	0.315	3.88	5.49	6.72	25.00	7.76	9.50	10.97	12.27	35	63
	422.988	●				BG							0.331	0.331	4.34	6.14	7.52	28.00	8.69	10.64	12.29	13.74	35	63
	423.008	●				BG							0.343	0.343	4.89	6.91	8.46	31.50	9.77	11.97	13.82	15.45	35	63
	423.048	●					BK						0.426	0.402	6.21	8.78	10.75	40.00	12.41	15.20	17.55	19.62	35	63
	423.088	●					BK						0.449	0.433	7.76	10.97	13.43	50.00	15.51	19.00	21.94	24.53	35	63
	423.128	●					BK						0.500	0.485	9.77	13.82	16.93	63.00	19.55	23.94	27.65	30.91	35	63
	423.148	●						BM					0.552	0.532	11.02	15.58	19.07	71.00	22.03	26.98	31.16	34.83	35	63
	423.208	●						BM					0.670	0.630	15.51	21.94	26.87	100.00	31.03	38.00	43.88	49.06	35	63
	423.288	●							BP				0.748	0.748	24.82	35.11	42.98	160.00	49.63	60.79	70.19	78.48	35	63
	423.368	●								BR			0.875	0.875	38.79	54.85	67.16	250.00	77.55	94.98	109.68	122.62	35	63
	423.448	●									BV		1.220	1.161	62.06	87.76	107.46	400.00	124.09	151.97	175.48	196.20	35	63

Also available in metric thread.

Conversion formula for this series: $\dot{V}_2 = \dot{V}_1 \cdot \sqrt{\frac{p_2}{p_1}}$

Ordering Type + Material no. + Connection = Ordering no.
 example: 422.888 + 1Y + BE = 422.888.1Y.BE



Assembly accessories can be found in Chapter 12 "Accessories".

➤ Tangential-flow full cone nozzles, plastic version

Series 422/423

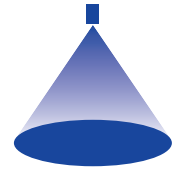

Features:

- Tangentially arranged supply of liquid
- Without swirl inserts
- Non-clogging
- Stable spray angle
- Uniform liquid distribution
- High chemical resistance

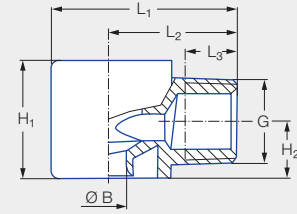
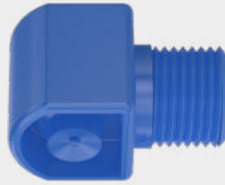

Applications:

- Surface spraying
- Cooling
- Cleaning and washing processes
- Foam control

Series 422/423

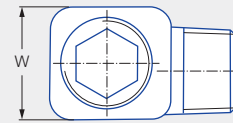

Connection	G	Dimensions [in]						Weight [lb]
		H ₁	H ₂	L ₁	L ₂	L ₃	Hex (mm)	
BC	1/4 NPT	0.63	0.31	1.10	0.79	0.39	16	0.02
BE	3/8 NPT	0.91	0.44	1.42	0.98	0.40	22	0.04
BG	1/2 NPT	1.50	0.76	1.95	1.32	0.52	32	0.09
CG	1/2 BSPT	1.50	0.76	1.95	1.32	0.52	32	0.09
CK	3/4 BSPT	1.97	0.96	2.30	1.52	0.73	41	0.11

Spray angle	Ordering number						Bore diameter B [in]	Narrowest free cross sections Ø [in]	V̇ water [gal/min]							Spray diameter D [in] (at p = 30 psi)	
	Type	Mat. no.	Connection						p [psi]								
		5E	PVDF	1/4 NPT	3/8 NPT	1/2 BSPT			3/4 BSPT	7	15	30	Liters per min. 2 bar	45	75		
60°	422.724	●		BE			0.142	0.142	0.82	1.20	1.69	6.30	2.07	2.68	3.72	10	20
90°	422.406	●	BC				0.059	0.057	0.13	0.19	0.27	1.00	0.33	0.42	0.59	20	35
	422.566	●	BC				0.091	0.087	0.32	0.47	0.67	2.50	0.82	1.06	1.48	20	36
	422.606	●		BE			0.102	0.098	0.41	0.60	0.85	3.15	1.04	1.34	1.86	20	36
	422.646	●		BE			0.118	0.114	0.52	0.76	1.07	4.00	1.32	1.70	2.36	20	36
	422.726	●		BE			0.146	0.142	0.82	1.20	1.69	6.30	2.07	2.68	3.72	20	38
	422.806	●		BE			0.183	0.181	1.30	1.90	2.69	10.00	3.29	4.25	5.90	20	38
	422.846	●		BE			0.209	0.209	1.62	2.37	3.36	12.50	4.11	5.31	7.38	20	38
	422.886	●		BE			0.228	0.228	2.08	3.04	4.30	16.00	5.26	6.80	9.45	20	40
	422.926	●			*BG		0.287	0.287	2.60	3.80	5.37	20.00	6.58	8.50	11.81	20	40
	422.966	●			CG		0.315	0.315	3.24	4.75	6.72	25.00	8.23	10.62	14.77	20	40
	423.006	●			CG		0.343	0.343	4.09	5.98	8.46	31.50	10.36	13.38	18.60	20	40
423.126	●				CK	0.472	0.472	8.18	11.97	16.93	63.00	20.73	26.76	37.21	20	40	

*only available in NPT



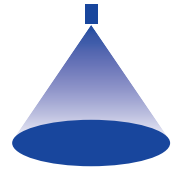

Spray angle	Ordering number						Bore diameter B [in]	Narrowest free cross sections Ø [in]	V̇ water [gal/min]							Spray diameter D [in] (at p = 30 psi)	
	Type	Mat. no.	Connection						p [psi]							H = 10 [in]	H = 20 [in]
		5E	1/4 NPT	3/8 NPT	1/2 BSPT	3/4 BSPT			7	15	30	Liters per min. 2 bar	45	75	145		
		PVDF															
120°	422.408	●	BC				0.059	0.057	0.13	0.19	0.33	1.00	0.33	0.42	0.59	26	47
	422.448	●	BC				0.065	0.063	0.16	0.24	0.34	1.25	0.41	0.53	0.74	26	47
	422.488	●	BC				0.075	0.075	0.21	0.30	0.43	1.60	0.53	0.68	0.95	26	47
	422.568	●	BC				0.094	0.094	0.32	0.47	0.67	2.50	0.82	1.06	1.48	26	47
	422.728	●		BE			0.157	0.154	0.82	1.20	1.69	6.30	2.07	2.68	3.72	30	55
	422.888	●		BE			0.260	0.236	2.08	3.04	4.30	16.00	5.26	6.80	9.45	33	58
	422.968	●			CG		0.315	0.315	3.24	4.75	6.72	25.00	8.23	10.62	14.77	35	63
	423.008	●			CG		0.343	0.343	4.09	5.98	8.46	31.50	10.36	13.38	18.60	35	63
423.128	●				CK	0.500	0.484	8.18	11.97	16.93	63.00	20.73	26.76	37.21	35	63	

Also available in metric thread.

Conversion formula for this series: $\dot{V}_2 = \dot{V}_1 \cdot \sqrt{\frac{p_2}{p_1}}$

Ordering Type + Material no. + Connection = Ordering no.
 example: 422.408 + 5E + BC = 422.408.5E.BC

 Assembly accessories can be found in Chapter 12 "Accessories".

➤ Tangential-flow full cone nozzles, plastic version with bayonet quick-release system Series 422

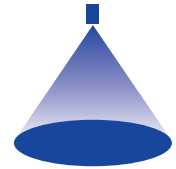

Features:

- Without swirl inserts
- Non-clogging
- Stable spray angle
- Simple and quick assembly
- Uniform liquid distribution
- High chemical resistance

Applications:

- Surface spraying
- Cooling
- Cleaning and washing processes
- Foam control



Series 422

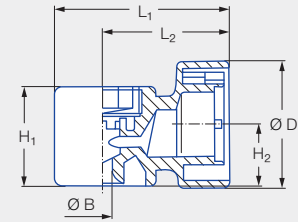
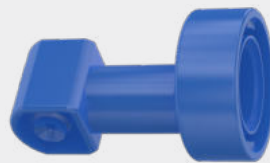

Figure 1

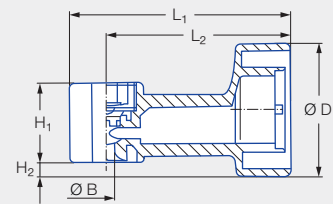



Figure 2

Type	Connection	Figure	Dimensions [in]					Weight [lb] (PVDF)
			H ₁	H ₂	L ₁	L ₂	Ø D	
422.644/422.606/422.608	KB	1	0.91	0.55	1.57	1.14	1.16	0.04
422.406/422.408/422.528	KB	2	0.69	0.14	1.89	1.57	1.16	0.03

Spray angle	Ordering number			Bore diameter B [in]	Narrowest free cross sections Ø [in]	V̇ water [gal/min]								Spray diameter D [in] (at p = 30 psi)		
	Type	Mat. no.				Connection	p [psi]									
		5E	53				liters per minute									
		PVDF	PP				Bayonet quick-release system	7	15	30	2 bar	45	75	145	H = 10 [in]	H = 20 [in]
60°	422.644		●	KB	0.114	0.114	0.52	0.76	1.07	4.00	1.32	1.70	2.36	10	20	
90°	422.406	●		KB	0.059	0.057	0.13	0.19	0.27	1.00	0.33	0.42	0.59	20	35	
	422.606	●		KB	0.098	0.098	0.41	0.60	0.85	3.15	1.04	1.34	1.86	20	36	
120°	422.408	●		KB	0.059	0.057	0.13	0.19	0.27	1.00	0.33	0.42	0.59	26	47	
	422.528	●		KB	0.083	0.079	0.26	0.38	0.54	2.00	0.66	0.85	1.18	26	47	
	422.608	●		KB	0.102	0.098	0.41	0.60	0.85	3.15	1.04	1.34	1.86	26	47	

Conversion formula for this series: $\dot{V}_2 = \dot{V}_1 \cdot \sqrt{\frac{p_2}{p_1}}$

Ordering Type + Material no. + Connection = Ordering no.
example: 422.644 + 53 + KB = 422.644.53.KB



Assembly accessories can be found in Chapter 12 "Accessories".

Cluster head nozzles Series 502/503

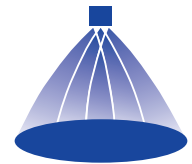

Features:

- Fine, uniform atomization
- Stable spray angle
- Space-saving installation
- Maintenance-friendly design
- High temperature and chemical resistance

Applications:

- Chlorine precipitation
- Absorption
- Dust suppression
- Degassing of liquids
- Desuperheating

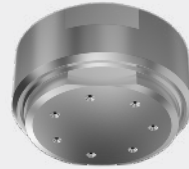

Series 502/503

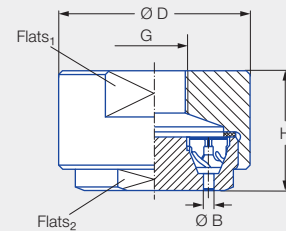
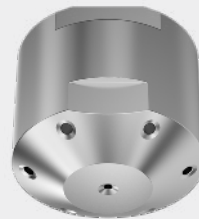

70° version

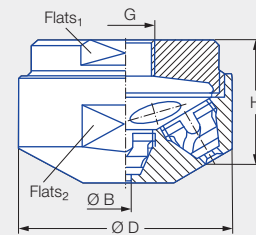

130° version

70° version

G	Dimensions [in]				Weight [lb] (brass)
	H	Ø D	Flats ₁ (mm)	Flats ₂ (mm)	
1/2 NPT	0.98	1.97	46	38	0.55
3/4 NPT	1.81	2.95	65	55	1.92

130° version

G	Dimensions [in]				Weight [lb] (brass)
	H	Ø D	Flats ₁ (mm)	Flats ₂ (mm)	
1/2 NPT	1.10	1.57	27	36	0.33
3/4 NPT	2.09	2.36	50	55	0.90

Spray angle	Ordering number					Bore diameter B [in]	Narrowest free cross sections Ø [in]	V̇ water [gal/min]						Spray diameter D [in] (at p = 30 psi)	
	Type	Mat. no.		Connection				p [psi]							
		17 ¹	30	1/2 NPT	3/4 NPT			Liters per min.		H = 20 [in]		H = 40 [in]			
		Stainless steel 316Ti/ Stainless steel 316L	Brass					7	15	30	2 bar	75	145		
70°	502.445		●	BH		0.035	0.020	–	–	0.34	1.25	0.53	0.74	10	14
	502.985	●		BL		0.130	0.079	3.63	5.32	7.52	28.00	11.89	16.54	24	39
	503.065	●		BL		0.193	0.079	5.84	8.55	12.09	45.00	19.12	26.58	36	60
	503.115	●	●	BL		0.236	0.079	7.79	11.40	16.12	60.00	25.49	35.44	51	78
130°	502.448	●	●	BH		0.035	0.020	–	–	0.34	1.25	0.53	0.74	12	14
	502.548	●	●	BH		0.071	0.020	–	0.43	0.60	2.24	0.95	1.32	18	22
	502.588	●	●	BL		0.039	0.039	0.36	0.53	0.75	2.80	1.19	1.65	32	35
	502.748	●	●	BL		0.075	0.079	0.92	1.35	1.91	7.10	3.02	4.19	43	55
	502.798	●	●	BL		0.114	0.079	1.23	1.80	2.55	9.50	4.04	5.61	47	51
	502.838	●	●	BL		0.114	0.079	1.53	2.24	3.17	11.80	5.01	6.97	59	81
	502.908	●	●	BL		0.157	0.079	2.34	3.42	4.84	18.00	7.65	10.63	70	104
	503.028	●	●	BL		0.165	0.079	4.61	6.74	9.54	35.50	15.08	20.97	81	124
	503.118	●	●	BL		0.256	0.079	7.79	11.40	16.12	60.00	25.49	35.44	91	140

¹ We reserve the right to supply material 316Ti or 316L under material no. 17.

Also available in metric thread.

Conversion formula for this series: $\dot{V}_2 = \dot{V}_1 \cdot \sqrt{\frac{p_2}{p_1}}$

Ordering Type + Material no. + Connection = Ordering no.
example: 502.445 + 30 + BH = 502.445.30.BH

Assembly accessories can be found in Chapter 12 "Accessories".

Deflector-plate nozzles Series 524/525

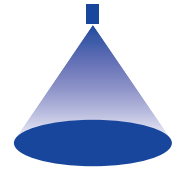

Features:

- Full cone atomization
- Large impact area
- Non-clogging

Applications:

- Fire fighting
- Sprinkling
- Dust suppression

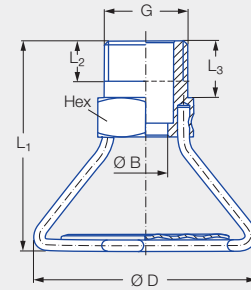

Series 524/525

G	Dimensions [in]					Weight [lb] (brass)
	L ₁	L ₂	L ₃	Ø D	Hex (mm)	
1/2 NPT	2.11	0.43	0.57	2.2	24	0.15

Spray angle	Ordering number				Bore diameter B [in]	V̇ water [gal/min]						Spray diameter D [in] (at p = 30 psi)			
	Type	Mat. no.		Connection		p [psi]									
		17 ¹	30	1/2 Male NPT		BSPP	Liters per min.							H = 40 [in]	H = 120 [in]
		Stainless steel 316Ti/ Stainless steel 316L	Brass					7	15	30	2 bar	45	75		
180°	524.809	●	●	BG	00	0.157	1.30	1.90	2.69	10.00	3.29	4.25	5.91	150	169
	525.049	●	●	BG	00	0.315	5.19	7.60	10.75	40.00	13.16	16.99	23.63	394	453
	525.109	●	●	BG	00	0.366	7.27	10.64	15.04	56.00	18.43	23.79	33.08	413	502
	525.169	●	●	BG	00	0.429	10.38	15.20	21.49	80.00	26.32	33.98	47.25	413	571
	525.229	●	●	BG	00	0.480	14.53	21.28	30.09	112.00	36.85	47.58	66.15	295	453
	525.269	●	●	BG	00	0.484	18.17	26.60	37.61	140.00	46.06	59.47	82.69	276	472

¹ We reserve the right to supply material 316Ti or 316L under material no. 17.

Also available in metric thread.

Conversion formula for this series: $\dot{V}_2 = \dot{V}_1 \cdot \sqrt{\frac{p_2}{p_1}}$

Ordering Type + Material no. + Connection = Ordering no.
example: 524.809 + 17 + BG = 524.809.17.BG



Assembly accessories can be found in Chapter 12 "Accessories".

FLAT FAN NOZZLES

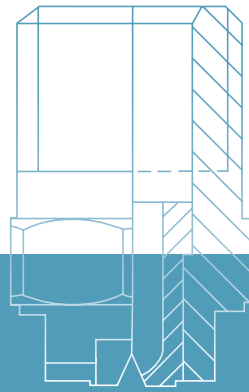

FLAT FAN NOZZLES OVERVIEW OF TYPES

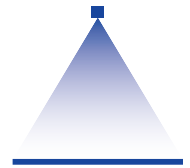

Lechler flat fan nozzles produce evenly distributed jets of water. Flat fan nozzles are generally used in cleaning processes and throughout many areas of surface treatment. Numerous designs – including tongue-type nozzles for special applications – and extensive assembly accessories enable easy installation as well as quick nozzle changeovers.

Standard flat fan nozzles

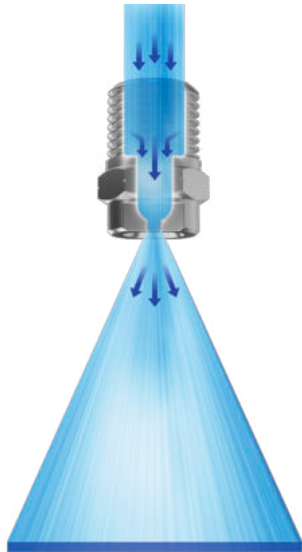

- Particularly high-energy spray with spray angles of up to 120°
- Parabolic liquid distribution
- Unaffected by transient pressures
- Simple and cost-saving assembling options

Tongue-type nozzles

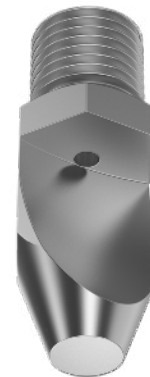

- Special design in which a solid stream is diverted by a deflector plate
- Powerful, sharply delimited spray
- Shape of the deflector plate determines the spray angle
- Clog resistant due to large free cross-sections

Spray angle in degrees



Flow rate in US gal/min at 40 psi

Conversion: Value · 3.22 = flow rate in l/min at 2 bar







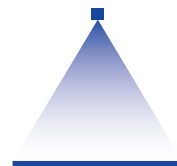

example: 0.2 gal/min at 40 psi = 0.644 l/min at 2 bar

Good to know

Information on the arrangement of several flat fan nozzles can be found in Chapter "Planning Aids" on page 27.

FLAT FAN NOZZLES OVERVIEW OF SERIES







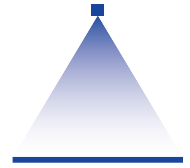

		Standard flat fan nozzles				
						
Series		632/633	610	612	616/617	621
Information on page		201	204	206	209	upon request
Pressure range	Low pressure	•	•	•	•	•
	High pressure					
 Flow rate at p = 75 psi	Low < 1.06 gal/min	•	•	•		
	Medium 1.06 gal/min–4.23 gal/min	•	•	•	•	
	High 4.23 gal/min–13.21 gal/min	•		•	•	
	Very high > 13.21 gal/min				•	•
 Spray angle	Small 20°–45°	•	•	•	•	•
	Medium 60°–90°	•	•	•	•	•
	Large 120°–140°	•	•	•	•	
 Nozzle material	Stainless steel	•	•	•	•	
	Brass	•	•	•	•	
	Plastic	•				•
 Nozzle connection		1/8 NPT 1/4 NPT 3/8 NPT 1/2 NPT	1/8 NPT	1/4 NPT	3/4 NPT	1-1/4 BSPP















Standard flat fan nozzles

							
	625	612.xxx.5E.03 Press-in nozzle	672/673	652	656/657	684	686
	upon request	209	210	214	217	217	218
	•	•	•	•	•	•	•
		• (at p = 30 psi)	•	•		•	•
			•	•	•	•	•
			•	•	•		•
	•		•		•		
	•		•	•	•		
	•	•	•	•	•		•
	•	•	•	•	•	•	•
		•	•	•	•		•
			•	•	•		•
	•	•		•		•	•
	2 BSPP	For pressing into pipes	For pressing into pipes	Assembly with retaining nut 3/8 BSPP	Assembly with retaining nut 3/4 BSPP	Assembly with retaining nut 3/8 BSPP	1/4 NPT 1/8 NPT 3/8 NPT 1/2 NPT



		Standard flat fan nozzles			
					
Series		688/689	680	690	676
Information on page		220	221	222	226
Pressure range	Low pressure	•	•	•	•
	High pressure				
 Flow rate at p = 75 psi	Low < 4 gal/min	•	•	•	•
	Medium 1.06 gal/min–4.23 gal/min	•	•	•	•
	High 4.23 gal/min–13.21 gal/min	•	•	•	
	Very high > 13.21 gal/min				
 Spray angle	Small 20°–45°	•	•	•	•
	Medium 60°–90°		•	•	•
	Large 120°–140°				•
 Nozzle material	Stainless steel	•	•	•	•
	Brass				•
	Plastic	•			
Nozzle connection		3/8 NPT 3/4 NPT	5/8 - 18 UNF	Assembly with retaining nut BSPB	Assembly with retaining nut Welded nipple Threaded nipple Threaded socket



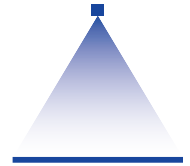

Standard flat fan nozzles

			
660	664/665	6M2	686.XXX.WW.08
226	229	by request	by request
•	•	•	
			•
•	•	•	•
•	•	•	•
	•	•	•
	•		
•	•	•	
•	•	•	•
•	•	•	•
•	•	•	•
•	•	•	•
Assembly with retaining nut 3/8 BSPP and dovetail guide	Assembly with retaining nut 3/8 BSPP and dovetail guide	Assembly with retaining nut Weld nipple	Assembly with retaining nut Weld nipple

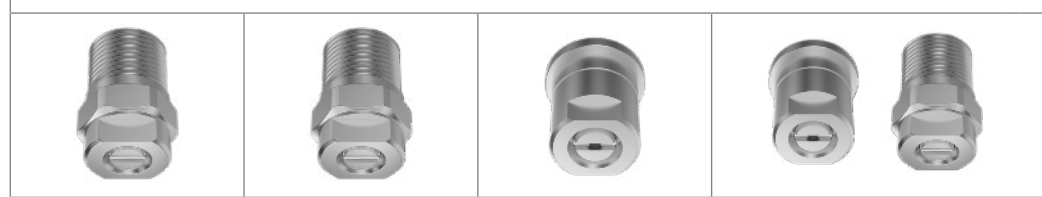



High pressure flat fan nozzles

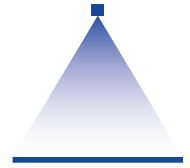

Series		602	608	652	6FH with spray stabilizer
Information on page		234	235	236	237
Pressure range	Low pressure				
	High pressure	●	●	●	●
 Flow rate at p = 75 psi	Low < 4 gal/min				
	Medium 1.06 gal/min–4.23 gal/min	● (at p = 1160 psi)	● (at p = 1160 psi)	● (at p = 1160 psi)	● (at p = 1160 psi)
	High 4.23 gal/min–13.21 gal/min	● (at p = 1160 psi)	● (at p = 1160 psi)	● (at p = 1160 psi)	● (at p = 1160 psi)
	Very high > 13.21 gal/min	● (at p = 1160 psi)		● (at p = 1160 psi)	● (at p = 1160 psi)
 Spray angle	Small 20°–45°	●	●	●	●
	Medium 60°–90°	●	●	●	●
	Large 120°–140°				
 Nozzle material	Stainless steel	●	●	●	●
	Brass				
	Plastic				
 Nozzle connection		1/4 BSPT 1/4 NPT	1/8 BSPT 1/8 NPT	Assembly with retaining nut 3/8 BSPP	1/8 BSPT 1/8 NPT 1/4 BSPT 1/4 NPT Assembly with retaining nut 3/8 BSPP



Surface technology flat fan nozzles

Surface technology flat fan nozzles					
					
652 Belt lubrication nozzle	564	646	676/677 MEMOSPRAY	676 Easy-Clip	
239	238	239	243	247	
•		•	•	•	
	•				
• (at p = 45 psi)		•			
	•	•	• (at p = 30 psi)	• (at p = 30 psi)	
			• (at p = 30 psi)	• (at p = 30 psi)	
		•	•		
•	•		•	•	
•	•		•		
•	•	•	•		
•		•	•	•	
Assembly with retaining nut 3/8 BSPP	1/4 NPT	Assembly with bayonet quick-release system	Eyelet clamps for following pipe sizes: 1 1 1/4 1 1/2 2	Eyelet clamps for following pipe sizes: 1 1 1/4 1 1/2 2	

Low pressure flat fan nozzles

Series 632/633

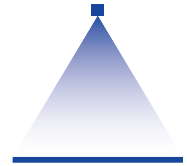

Features:

- Uniform, parabolic liquid distribution
- Stable spray angle
- Tapered, self-sealing thread

Applications:

- Spray cleaning
- Surface cleaning
- Strainer insert cleaning
- Coating processes
- Belt cleaning
- Lubrication processes



Series 632/633

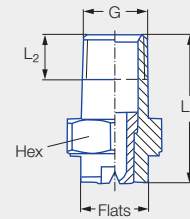

Figure 1

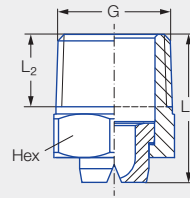

Figure 2

Connection	Figure	G	Dimensions [in]				Weight [lb] (Brass)
			L ₁	L ₂	Hex (mm)	Flats (mm)	
BA	1	1/8 NPT	0.87	0.26	14	10	0.037
BC	1	1/4 NPT	0.87	0.38	14	10	0.044
BE	2	3/8 NPT	0.87	0.40	17	–	0.066
BG	2	1/2 NPT	1.06	0.52	22	–	0.088

Spray angle	Type	Ordering number								Equivalent bore diameter A [in]	Narrowest free cross section Ø [in]	V̇ water [gal/min]								Spray width B [in] (at p = 75 psi)	
		Material number				Connection						p [psi]									
		16 ¹	17 ²	30	5E	1/8 NPT	1/4 NPT	3/8 NPT	1/2 NPT			7	15	30	45	75	liters per minute	100	145		
		Stainless steel 303/ Stainless steel 304	Stainless steel 316Ti/ Stainless steel 316L	Brass	PVDF							5 bar									
20°	632.301	●	●	●	●	BA	BC			0.03	0.02	0.04*	0.06*	0.09	0.11	0.14	0.51	0.16	0.19	3	6
	632.361	●	●	●	●	BA	BC			0.04	0.03	0.08*	0.12*	0.17	0.21	0.27	1.00	0.31	0.37	3	6
	632.441	●	●	●	●	BA	BC			0.05	0.04	0.16*	0.24	0.34	0.41	0.53	1.98	0.61	0.74	3	6
	632.481	●	●	●	●	BA	BC			0.06	0.05	0.21*	0.30	0.43	0.53	0.68	2.53	0.78	0.95	3	6
30°	632.302	●	●	●	●	BA	BC			0.02	0.02	0.04*	0.06*	0.09	0.11	0.14	0.51	0.16	0.19	5	9
	632.362	●	●	●	●	BA	BC			0.04	0.03	0.08*	0.12*	0.17	0.21	0.27	1.00	0.31	0.37	5	9
	632.402	●	●	●	●	BA	BC			0.05	0.035	0.13*	0.19	0.27	0.33	0.42	1.58	0.49	0.59	5	9
	632.482	●	●	●	●	BA	BC			0.06	0.04	0.21*	0.30	0.43	0.53	0.68	2.53	0.78	0.95	5	9
	632.562	●	●	●	●	BA	BC			0.08	0.06	0.32	0.47	0.67	0.82	1.06	3.95	1.23	1.48	5	9
	632.642	●	●	●			BC			0.10	0.07	0.52	0.76	1.08	1.32	1.70	6.33	1.96	2.36	6	10
	632.722	●	●	●			BC			0.12	0.09	0.82	1.20	1.69	2.07	2.68	9.96	3.09	3.72	6	10
	632.762	●	●	●			BC			0.14	0.11	1.04	1.52	2.15	2.63	3.30	12.65	3.92	4.73	6	10
	632.802	●	●	●			BC			0.16	0.12	1.30	1.90	2.69	3.29	4.25	15.81	4.90	5.91	6	10
	632.882	●	●	●				BG		0.20	0.16	2.08	3.04	4.30	5.26	6.80	25.32	7.85	9.45	6	10
	632.922	●	●	●				BG		0.22	0.17	2.60	3.80	5.37	6.58	8.49	31.65	9.81	11.81	6	10
	632.962	●	●	●				BG		0.24	0.19	3.24	4.75	6.71	8.22	10.62	39.52	12.26	14.76	6	10
633.002	●						BG		0.28	0.22	4.09	5.99	8.46	10.37	13.38	49.82	15.45	18.61	6	10	

* Differing spray pattern.

¹ We reserve the right to supply material 303 or 304 under material no. 16.

² We reserve the right to supply material 316Ti or 316L under material no. 17.

Spray angle	Ordering number								Equivalent bore diameter A [in]	Narrowest free cross section Ø [in]	V̇ water [gal/min]								Spray width B [in] (at p = 75 psi)			
	Type	Material number				Connection					p [psi]								H = 10 [in]	H = 20 [in]		
		16 ¹	17 ²	30	5E	1/8 NPT	1/4 NPT	3/8 NPT			1/2 NPT	liters per minute	5 bar	100	145	7	15	30			45	75
		Stainless steel 303/ Stainless steel 304	Stainless steel 316Ti/ Stainless steel 316L	Brass	PVDF																	
45°	632.303	●	●	●	●	BA	BC			0.03	0.02								0.04*	0.06*		
	632.363	●	●	●	●	BA	BC			0.04	0.023	0.08*	0.12*	0.17	0.21	0.27	1.00	0.31	0.37	7	14	
	632.403	●	●	●	●	BA	BC			0.05	0.035	0.13*	0.19	0.27	0.33	0.42	1.58	0.49	0.59	8	15	
	632.483	●	●	●	●	BA	BC			0.06	0.04	0.21*	0.30	0.43	0.53	0.68	2.53	0.78	0.95	8	15	
	632.563	●	●	●	●	BA	BC			0.08	0.06	0.32	0.47	0.67	0.82	1.06	3.95	1.23	1.48	8	16	
	632.643	●	●	●	●	BA	BC			0.10	0.07	0.52	0.76	1.08	1.32	1.70	6.33	1.96	2.36	9	16	
	632.673	●	●	●	●		BC	BE			0.11	0.08	0.62	0.90	1.28	1.56	2.02	7.51	2.33	2.81	9	17
	632.723	●	●	●	●		BC	BE			0.12	0.09	0.82	1.20	1.69	2.07	2.68	9.96	3.09	3.72	9	17
	632.763	●	●	●	●		BC	BE			0.14	0.10	1.04	1.52	2.15	2.63	3.30	12.65	3.92	4.73	9	17
	632.803	●	●	●	●		BC	BE	BG		0.16	0.12	1.30	1.90	2.69	3.29	4.25	15.81	4.90	5.91	9	17
	632.843	●	● ¹	●	●		BC		BG		0.18	0.13	1.62	2.37	3.36	4.11	5.31	19.76	6.13	7.38	9	17
	632.883	● ¹	● ¹	● ¹	● ³		BC		BG		0.20	0.15	2.08	3.04	4.30	5.26	6.80	25.30	7.85	9.45	9	17
632.923	●	●	●	●				BG		0.22	0.165	2.60	3.80	5.37	6.58	8.49	31.62	9.81	11.81	9	17	
632.963	●	●	●	●				BG		0.24	0.173	3.24	4.75	6.72	8.23	10.62	39.53	12.26	14.77	9	17	
60°	632.304	●	●	●	●	BA	BC			0.03	0.016	0.04*	0.06*	0.09	0.11	0.14	0.51	0.16	0.19	10	19	
	632.334	●	●	●	●	BA	BC			0.035	0.02	0.06*	0.09*	0.12	0.15	0.19	0.71	0.22	0.27	10	19	
	632.364	●	●	●	●	BA	BC			0.04	0.022	0.08*	0.12*	0.17	0.20	0.26	1.00	0.31	0.37	10	20	
	632.404	●	●	●	●	BA	BC			0.047	0.03	0.13*	0.19	0.27	0.33	0.42	1.58	0.49	0.59	10	20	
	632.444	●	●	●	●	BA	BC			0.05	0.035	0.16*	0.24	0.34	0.41	0.53	1.98	0.61	0.74	10	20	
	632.484	●	●	●	● ³	BA	BC			0.06	0.04	0.21*	0.30	0.43	0.53	0.68	2.53	0.78	0.95	10	20	
	632.514	●	●	●	●	BA	BC			0.065	0.043	0.25*	0.36	0.51	0.62	0.81	3.00	0.93	1.12	11	20	
	632.564	●	●	●	●	BA	BC			0.08	0.05	0.32	0.47	0.67	0.82	1.06	3.95	1.23	1.48	11	21	
	632.604	●	●	●	●	BA	BC			0.09	0.06	0.41	0.60	0.85	1.04	1.34	4.98	1.54	1.86	11	21	
	632.644	●	●	●	● ³		BC	BE			0.10	0.063	0.52	0.76	1.08	1.32	1.70	6.33	1.96	2.36	11	21
	632.674	●	●	●	● ³		BC	BE			0.11	0.07	0.62	0.90	1.28	1.56	2.02	7.51	2.33	2.81	11	22
	632.724	●	●	●	● ³		BC	BE			0.12	0.08	0.82	1.20	1.69	2.07	2.68	9.96	3.09	3.72	11	22
	632.764	●	●	●	●		BC	BE			0.14	0.09	1.04	1.52	2.15	2.63	3.30	12.65	3.92	4.73	11	22
	632.804	●	●	●	● ³		BC		BG		0.16	0.10	1.30	1.90	2.69	3.29	4.25	15.81	4.90	5.91	11	23
	632.844	●	●	●	● ³		BC		BG		0.18	0.12	1.62	2.37	3.36	4.11	5.31	19.76	6.13	7.38	11	23
	632.884	●	●	●	● ³		BC		BG		0.20	0.13	2.08	3.04	4.30	5.26	6.80	25.30	7.85	9.45	11	23
	632.924	●	●	●	●				BG		0.22	0.16	2.60	3.80	5.37	6.58	8.49	31.62	9.81	11.81	11	23
	632.964	●	●	●	●				BG		0.24	0.17	3.24	4.75	6.72	8.23	10.62	39.53	12.26	14.77	11	23
633.004	●	●	●	●				BG		0.28	0.19	4.09	5.98	8.46	10.36	13.38	49.80	15.45	18.60	11	23	
633.044	●	●	●	●				BG		0.31	0.22	5.19	7.60	10.75	13.16	16.99	63.25	19.62	23.63	11	23	
633.084	●	●	●	●				BG		0.35	0.27	6.49	9.50	13.43	16.45	21.24	79.06	24.53	29.53	11	23	
75°	632.145	●		●		BA	BC			0.008	0.005	–	0.01*	0.014	0.017	0.021	0.08	0.025	0.03	15	27	
	632.165	●		●		BA	BC			0.008	0.005	–	0.01*	0.017	0.02	0.027	0.10	0.03	0.04	15	27	
	632.185	●		●		BA	BC			0.008	0.006	–	0.011*	0.02	0.03	0.035	0.13	0.04	0.05	15	27	
	632.215	●		●		BA	BC			0.016	0.008	–	0.02*	0.03	0.04	0.05	0.18	0.06	0.07	15	27	
	632.245	●		●		BA	BC			0.02	0.012	–	0.03*	0.04	0.05	0.07	0.26	0.08	0.10	15	27	
	632.275	●		●		BA	BC			0.023	0.012	0.03*	0.04*	0.06	0.07	0.09	0.35	0.11	0.13	15	27	

* Differing spray pattern.

¹ We reserve the right to supply material 303 or 304 under material no. 16.

² We reserve the right to supply material 316Ti or 316L under material no. 17.

³ Only available with Code BC.





Spray angle	Ordering number								Equivalent bore diameter A [in]	Narrowest free cross section Ø [in]	V̇ water [gal/min]								Spray width B [in] (at p = 75 psi)			
	Type	Material number				Connection					p [psi]								H = 10 [in]	H = 20 [in]		
		16 ¹	17 ²	30	5E	1/8 NPT	1/4 NPT	3/8 NPT			1/2 NPT	7	15	30	45	75	liters per minute 5 bar	100			145	
		Stainless steel 303/ Stainless steel 304	Stainless steel 316Ti/ Stainless steel 316L	Brass	PVDF																	
90°	632.216	●		●		BA	BC			0.016	0.008	–	0.02*	0.03	0.04	0.05	0.18	0.06	0.07	17	31	
	632.276	●		●		BA	BC			0.02	0.012	0.03*	0.04*	0.06	0.07	0.09	0.35	0.11	0.13	17	31	
	632.306	●	●	●	●	BA	BC			0.03	0.016	0.04*	0.06*	0.09	0.11	0.14	0.51	0.16	0.19	17	31	
	632.336	●	●	●	●	BA	BC			0.035	0.02	0.06*	0.09*	0.12	0.15	0.19	0.71	0.22	0.27	17	32	
	632.366	●	●	●	●	BA	BC			0.04	0.023	0.08*	0.12*	0.17	0.21	0.27	1.00	0.31	0.37	18	33	
	632.406	●	●	●	●	BA	BC			0.047	0.028	0.13*	0.19	0.27	0.33	0.42	1.58	0.49	0.59	18	33	
	632.446	●	●	●	●	BA	BC			0.05	0.03	0.16*	0.24	0.34	0.41	0.53	1.98	0.61	0.74	18	34	
	632.486	●	●	●	●	BA	BC			0.06	0.03	0.21*	0.30	0.43	0.53	0.68	2.53	0.78	0.95	19	34	
	632.516	●	●	●	●	BA	BC			0.065	0.035	0.25*	0.36	0.51	0.62	0.81	3.00	0.93	1.12	19	35	
	632.566	●	●	●	●	BA	BC			0.08	0.04	0.32	0.47	0.67	0.82	1.06	3.95	1.23	1.48	19	35	
	632.606	●	●	●	●	BA	BC			0.09	0.047	0.41	0.60	0.85	1.04	1.34	4.98	1.54	1.86	20	36	
	632.646	●	●	●	● ³		BC	BE			0.10	0.05	0.52	0.76	1.08	1.32	1.70	6.33	1.96	2.36	20	37
	632.676	●	●	●	● ³		BC	BE			0.11	0.06	0.62	0.90	1.28	1.56	2.02	7.51	2.33	2.81	20	37
	632.726	●	●	●	● ³		BC	BE			0.12	0.067	0.82	1.20	1.69	2.07	2.68	9.96	3.09	3.72	20	39
	632.766	●	●	●	● ³		BC	BE			0.14	0.07	1.04	1.52	2.15	2.63	3.40	12.65	3.92	4.73	21	39
	632.806	●	●	●	● ³		BC	BG			0.16	0.09	1.30	1.90	2.69	3.29	4.25	15.81	4.90	5.91	21	41
	632.846	●	●	●	● ³		BC	BG			0.18	0.09	1.62	2.37	3.36	4.11	5.31	19.76	6.13	7.38	21	41
	632.886	●	●	●	● ³		BC	BG			0.20	0.12	2.08	3.04	4.30	5.26	6.80	25.30	7.85	9.45	21	42
632.926	●	●	●	● ³		BC	BG			0.22	0.14	2.60	3.80	5.37	6.58	8.49	31.62	9.81	11.81	21	42	
632.966	●	●	●				BG			0.24	0.15	3.24	4.75	6.72	8.23	10.62	39.53	12.26	14.77	21	42	
120°	632.187	●		●		BA	BC			0.01	0.008	–	0.011*	0.02	0.03	0.035	0.13	0.04	0.05	25	42	
	632.217	●		●		BA	BC			0.016	0.008	–	0.02*	0.03	0.04	0.05	0.18	0.06	0.07	26	43	
	632.247	●		●		BA	BC			0.02	0.008	–	0.03*	0.04	0.05	0.07	0.26	0.08	0.10	26	43	
	632.277	●		●		BA	BC			0.024	0.012	0.03*	0.04*	0.06	0.07	0.09	0.35	0.11	0.13	17	45	
	632.307	●	●	●	●	BA	BC			0.03	0.012	0.04*	0.06*	0.09	0.11	0.14	0.51	0.16	0.19	17	49	
	632.337	●	●	●	●	BA	BC			0.035	0.016	0.06*	0.09*	0.12	0.15	0.19	0.71	0.22	0.27	17	53	
	632.367	●	●	●	●	BA	BC			0.04	0.02	0.08*	0.12*	0.17	0.21	0.27	1.00	0.31	0.37	18	56	
	632.407	●	●	●	●	BA	BC			0.047	0.024	0.13*	0.19	0.27	0.33	0.42	1.58	0.49	0.59	18	58	
	632.447	●	●	●	●	BA	BC			0.05	0.024	0.16*	0.24	0.34	0.41	0.53	1.98	0.61	0.74	18	60	
	632.487	●	●	●	●	BA	BC			0.06	0.024	0.21*	0.30	0.43	0.53	0.68	2.53	0.78	0.95	19	61	
	632.517	●	●	●	●	BA	BC			0.065	0.035	0.25*	0.36	0.51	0.62	0.81	3.00	0.93	1.12	19	61	
	632.567	●	●	●	●	BA	BC			0.08	0.035	0.32	0.47	0.67	0.82	1.06	3.95	1.23	1.48	19	63	
	632.607	●	●	●	●	BA	BC			0.09	0.04	0.41	0.59	0.83	1.02	1.32	4.98	1.56	1.86	34	64	
	632.647	●	●	●			BC	BE			0.10	0.05	0.53	0.75	1.06	1.29	1.67	6.33	1.98	2.36	35	65
	632.677	●	●	●	● ³		BC	BE			0.11	0.055	0.63	0.89	1.25	1.54	1.98	7.51	2.35	2.81	35	65
	632.727	●	●	●	● ³		BC	BE			0.12	0.06	0.82	1.20	1.69	2.07	2.68	9.96	3.09	3.72	35	66
	632.767	●	●	●	● ³		BC	BE			0.14	0.07	1.06	1.50	2.11	2.59	3.34	12.65	3.95	4.73	35	67
	632.807	●	●	●			BC	BG			0.16	0.08	1.30	1.90	2.69	3.29	4.25	15.81	4.90	5.91	35	67
632.847	●	●	●	● ³		BC	BG			0.18	0.09	1.62	2.37	3.36	4.11	5.31	19.76	6.13	7.38	35	67	
632.887	●	●	●				BG			0.20	0.10	2.08	3.04	4.30	5.26	6.80	25.30	7.85	9.45	36	67	
632.927	●	●	●				BG			0.22	0.11	2.60	3.80	5.37	6.58	8.49	31.62	9.81	11.81	36	67	

* Differing spray pattern.

¹ We reserve the right to supply material 303 or 304 under material no. 16.

² We reserve the right to supply material 316Ti or 316L under material no. 17.

³ Only available with Code BC.

Conversion formula for this series: $\dot{V}_2 = \dot{V}_1 \cdot \sqrt{\frac{p_2}{p_1}}$

Ordering Type + Material no. + Code = Ordering no.
example: 632.216 + 16 + BA = 632.216.16.BA



Assembly accessories can be found in Chapter 12 "Accessories".



Low pressure flat fan nozzles

Series 610

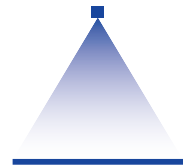

Features:

- Uniform, parabolic liquid distribution
- Stable spray angle
- Compact design for narrow installation conditions

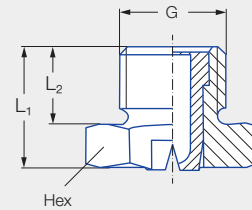
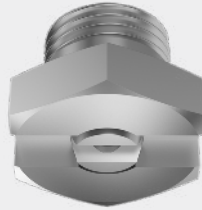

Applications:

- Spray cleaning
- Surface cleaning
- Strainer insert cleaning
- Coating processes
- Belt cleaning
- Lubrication processes

Series 610

G	Dimensions [in]			Weight [lb] Brass
	L ₁	L ₂	Hex (mm)	
1/8 BSPP	0.43	.028	14	0.02

Spray angle	Ordering number		Equivalent bore diameter A [in]	Narrowest free cross section Ø [in]	V̇ water [gal/min]									Spray width B [in] (at p = 75 psi)				
	Type	Material number			p [psi]													
		16			30						liters per minute			H = 10 [in]	H = 20 [in]			
		Stainless steel 303			Brass	7	15	30	45	75	5 bar	100	145					
20°	610.301	●	●	0.03	0.02	0.04*	0.06*	0.08	0.11	0.13	0.51	0.16	0.19	3	6			
	610.361	●	●	0.04	0.03	0.08*	0.12*	0.17	0.20	0.26	1.00	0.31	0.37	3	6			
	610.441	●	●	0.05	0.04	0.16*	0.24	0.34	0.41	0.53	1.98	0.61	0.74	3	6			
	610.481	●	●	0.06	0.05	0.21*	0.30	0.43	0.53	0.68	2.53	0.78	0.95	3	6			
30°	610.302	●	●	0.03	0.02	0.04*	0.06*	0.08	0.11	0.13	0.51	0.16	0.19	5	9			
	610.362	●	●	0.04	0.03	0.08*	0.12*	0.17	0.20	0.26	1.00	0.31	0.37	5	9			
	610.402	●	●	0.05	0.035	0.13*	0.19	0.27	0.33	0.42	1.58	0.49	0.59	5	9			
	610.482	●	●	0.06	0.04	0.21*	0.30	0.43	0.53	0.68	2.53	0.78	0.95	5	9			
	610.562	●	●	0.08	0.06	0.32	0.47	0.67	0.82	1.06	3.95	1.23	1.48	5	9			
45°	610.303	●	●	0.03	0.019	0.04*	0.06*	0.08	0.11	0.13	0.51	0.16	0.19	7	13			
	610.363	●	●	0.04	0.02	0.08*	0.12*	0.17	0.20	0.26	1.00	0.31	0.37	7	14			
	610.403	●	●	0.05	0.035	0.13*	0.19	0.27	0.33	0.42	1.58	0.49	0.59	8	15			
	610.483	●	●	0.06	0.04	0.21*	0.30	0.43	0.53	0.68	2.53	0.78	0.95	8	15			
	610.563	●	●	0.08	0.06	0.32	0.47	0.67	0.82	1.06	3.95	1.23	1.48	8	16			
	610.643	●	●	0.09	0.07	0.52	0.76	1.08	1.32	1.70	6.33	1.96	2.36	9	16			

* Differing spray pattern.
NPT version available by request





Spray angle	Ordering number			Equivalent bore diameter A [in]	Narrowest free cross section Ø [in]	V̇ water [gal/min]								Spray width B [in] (at p = 75 psi)	
	Type	Material number				p [psi]									
		16	30			7	15	30	45	75	liters per minute 5 bar	100	145		
60°	610.304	●	●	0.03	0.015	0.04*	0.06*	0.09	0.11	0.13	0.51	0.16	0.19	10	19
	610.334	●	●	0.035	0.02	0.06*	0.09*	0.12	0.15	0.19	0.71	0.22	0.27	10	19
	610.364	●	●	0.04	0.023	0.08*	0.12*	0.17	0.20	0.26	1.00	0.31	0.37	10	20
	610.404	●	●	0.047	0.03	0.13*	0.19	0.24	0.33	0.42	1.58	0.49	0.59	10	20
	610.444	●	●	0.05	0.035	0.16*	0.24	0.34	0.41	0.53	1.98	0.61	0.74	10	20
	610.484	●	●	0.06	0.04	0.21*	0.30	0.43	0.53	0.68	2.53	0.78	0.95	10	20
	610.514	●	●	0.065	0.043	0.25*	0.36	0.51	0.62	0.81	3.00	0.93	1.12	11	20
	610.564	●	●	0.08	0.05	0.32	0.47	0.67	0.82	1.06	3.95	1.23	1.48	11	21
610.604	●	●	0.09	0.06	0.41	0.60	0.85	1.04	1.34	4.98	1.54	1.86	11	21	
75°	610.145	●	●	0.008	0.004	-	0.01*	0.014	0.017	0.021	0.08	0.025	0.03	15	27
	610.165	●	●	0.008	0.005	-	0.01*	0.017	0.02	0.027	0.10	0.03	0.04	15	27
	610.185	●	●	0.008	0.006	-	0.011*	0.02	0.03	0.035	0.13	0.04	0.05	15	27
	610.215	●	●	0.016	0.008	-	0.02*	0.03	0.04	0.05	0.18	0.06	0.07	15	27
	610.245	●	●	0.02	0.012	-	0.03*	0.04	0.05	0.07	0.26	0.08	0.10	15	27
	610.275	●	●	0.023	0.012	0.03*	0.04*	0.06	0.07	0.09	0.35	0.11	0.13	15	27
90°	610.216	●	●	0.016	0.008	-	0.02*	0.03	0.04	0.05	0.18	0.06	0.07	17	31
	610.276	●	●	0.023	0.012	0.03*	0.04*	0.06	0.07	0.09	0.35	0.11	0.13	17	31
	610.306	●	●	0.03	0.015	0.04*	0.06*	0.08	0.11	0.13	0.51	0.16	0.19	17	31
	610.336	●	●	0.035	0.02	0.06*	0.09*	0.12	0.15	0.19	0.71	0.22	0.27	17	32
	610.366	●	●	0.04	0.02	0.08*	0.12*	0.17	0.20	0.26	1.00	0.31	0.37	18	33
	610.406	●	●	0.047	0.028	0.13*	0.19	0.24	0.33	0.42	1.58	0.49	0.59	18	33
	610.446	●	●	0.05	0.03	0.16*	0.24	0.34	0.41	0.53	1.98	0.61	0.74	18	34
	610.486	●	●	0.06	0.03	0.21*	0.30	0.43	0.53	0.68	2.53	0.78	0.95	19	34
	610.516	●	●	0.065	0.035	0.25*	0.36	0.51	0.62	0.81	3.00	0.93	1.12	19	35
	610.566	●	●	0.08	0.043	0.32	0.47	0.67	0.82	1.06	3.95	1.23	1.48	19	35
610.606	●	●	0.09	0.05	0.41	0.60	0.85	1.04	1.34	4.98	1.54	1.86	20	36	
120°	610.187	●	●	0.014	0.008	-	0.011*	0.02	0.03	0.035	0.13	0.04	0.05	15	42
	610.217	●	●	0.016	0.008	-	0.02*	0.03	0.04	0.05	0.18	0.06	0.07	15	43
	610.247	●	●	0.02	0.008	-	0.03*	0.04	0.05	0.07	0.26	0.08	0.10	15	43
	610.277	●	●	0.024	0.012	-	0.04*	0.06	0.07	0.09	0.35	0.11	0.13	15	45
	610.307	●	●	0.028	0.012	0.04*	0.06*	0.08	0.11	0.13	0.51	0.16	0.19	28	49
	610.337	●	●	0.03	0.015	0.06*	0.09*	0.12	0.15	0.19	0.71	0.22	0.27	29	53
	610.367	●	●	0.04	0.02	0.08*	0.12*	0.17	0.20	0.26	1.00	0.31	0.37	31	56
	610.407	●	●	0.047	0.023	0.13*	0.19	0.24	0.33	0.42	1.58	0.49	0.59	33	58
	610.447	●	●	0.05	0.023	0.16*	0.24	0.34	0.41	0.53	1.98	0.61	0.74	33	60
	610.487	●	●	0.06	0.023	0.21*	0.30	0.43	0.53	0.68	2.53	0.78	0.95	33	61
	610.517	●	●	0.065	0.035	0.25*	0.36	0.51	0.62	0.81	3.00	0.93	1.12	33	61
	610.567	●	●	0.08	0.035	0.32	0.47	0.67	0.82	1.06	3.95	1.23	1.48	34	63
	610.607	●	●	0.087	0.043	0.41	0.60	0.85	1.04	1.34	4.98	1.54	1.86	34	64

* Differing spray pattern.
NPT version available by request

Conversion formula for this series: $\dot{V}_2 = \dot{V}_1 \cdot \sqrt{\frac{p_2}{p_1}}$

Ordering Type + Material no. = Ordering no.
example: 610.304 + 16 = 610.304.16

Assembly accessories can be found in Chapter 12 "Accessories".



Low pressure flat fan nozzles

Series 612

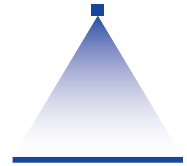

Features:

- Uniform, parabolic liquid distribution
- Stable spray angle
- Compact design for narrow installation conditions



Series 612

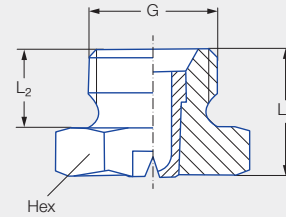

Applications:

- Spray cleaning
- Surface cleaning
- Strainer insert cleaning
- Coating processes
- Belt cleaning
- Lubrication processes

G	Dimensions [in]			Weight [lb] Brass
	L ₁	L ₂	Hex (mm)	
1/4 BSPP	.51	.31	17	.03

Spray angle	Ordering number				Equivalent bore diameter A [in]	Narrowest free cross section Ø [in]	V̇ water [gal/min]										Spray width B [in] (at p = 75 psi)	
	Type	Material number					p [psi]											
		16	17 ¹	30			5 bar					liters per minute						
		Stainless steel 303	Stainless steel 316Ti/ Stainless steel 316L	Brass			7	15	30	45	75	100	145	5	10	15	20	
20°	612.301	●	●	●	0.03	0.02	0.04*	0.06*	0.09	0.11	0.14	0.51	0.16	0.19	3	6		
	612.361	●	●	●	0.04	0.03	0.08*	0.12*	0.17	0.21	0.27	1.00	0.31	0.37	3	6		
	612.441	●	●	●	0.05	0.04	0.16*	0.24	0.34	0.41	0.53	1.98	0.61	0.74	3	6		
	612.481	●	●	●	0.06	0.05	0.21*	0.30	0.43	0.53	0.68	2.53	0.78	0.95	3	6		
30°	612.302	●	●	●	0.02	0.02	0.04*	0.06*	0.09	0.11	0.14	0.51	0.16	0.19	5	9		
	612.362	●	●	●	0.04	0.03	0.08*	0.12*	0.17	0.21	0.27	1.00	0.31	0.37	5	9		
	612.402	●	●	●	0.05	0.035	0.13*	0.19	0.27	0.33	0.42	1.58	0.49	0.59	5	9		
	612.482	●	●	●	0.06	0.04	0.21*	0.30	0.43	0.53	0.68	2.53	0.78	0.95	5	9		
	612.562	●	●	●	0.08	0.06	0.32	0.47	0.67	0.82	1.06	3.95	1.23	1.48	5	9		
	612.642	●	●	●	0.10	0.07	0.52	0.76	1.08	1.32	1.70	6.33	1.96	2.36	6	10		
	612.722	●	●	●	0.12	0.09	0.82	1.20	1.69	2.07	2.68	9.96	3.09	3.72	6	10		
	612.762	●	●	●	0.14	0.11	1.04	1.52	2.15	2.63	3.40	12.65	3.92	4.73	6	10		
45°	612.303	●	●	●	0.03	0.02	0.04*	0.06*	0.08	0.11	0.13	0.51	0.16	0.19	7	13		
	612.363	●	●	●	0.04	0.023	0.08*	0.12*	0.17	0.20	0.26	1.00	0.31	0.37	7	14		
	612.403	●	●	●	0.05	0.035	0.13*	0.19	0.26	0.32	0.42	1.58	0.49	0.59	8	15		
	612.483	●	●	●	0.06	0.04	0.21*	0.30	0.43	0.53	0.68	2.53	0.78	0.95	8	15		
	612.563	●	●	●	0.08	0.06	0.32	0.47	0.67	0.82	1.06	3.95	1.23	1.48	8	16		
	612.643	●	●	●	0.10	0.07	0.52	0.76	1.08	1.32	1.70	6.33	1.96	2.36	9	16		
	612.723	●	●	●	0.12	0.09	0.82	1.20	1.69	2.07	2.68	9.96	3.09	3.72	9	17		
	612.763	●	●	●	0.14	0.11	1.04	1.52	2.15	2.63	3.40	12.65	3.92	4.73	9	17		
612.803	●	●	●	0.16	0.12	1.30	1.90	2.69	3.24	4.25	15.81	4.90	5.91	9	17			

* Differing spray pattern.

¹ We reserve the right to supply material 316Ti or 316L under material no. 17.

NPT version available by request





Spray angle	Ordering number				Equivalent bore diameter A [in]	Narrowest free cross section Ø [in]	V̇ water [gal/min]								Spray width B [in] (at p = 75 psi)	
	Type	Material number					p [psi]								H = 10 [in]	H = 20 [in]
		16	17 ¹	30			7	15	30	45	75	liters per minute 5 bar	100	145		
		Stainless steel 303	Stainless steel 316Ti/ Stainless steel 316L	Brass												
60°	612.304	●	●	●	0.03	0.016	0.04*	0.06*	0.09	0.11	0.14	0.51	0.16	0.19	10	19
	612.334	●	●	●	0.035	0.02	0.06*	0.09*	0.12	0.15	0.19	0.71	0.22	0.27	10	19
	612.364	●	●	●	0.04	0.024	0.08*	0.12*	0.17	0.21	0.27	1.00	0.31	0.37	10	20
	612.404	●	●	●	0.047	0.03	0.13*	0.19	0.27	0.33	0.42	1.58	0.49	0.59	10	20
	612.444	●	●	●	0.05	0.035	0.16*	0.24	0.34	0.41	0.53	1.98	0.61	0.74	10	20
	612.484	●	●	●	0.06	0.04	0.21*	0.30	0.43	0.53	0.68	2.53	0.78	0.95	10	20
	612.514	●	●	●	0.065	0.043	0.25*	0.36	0.51	0.62	0.81	3.00	0.93	1.12	11	20
	612.564	●	●	●	0.08	0.05	0.32	0.47	0.67	0.82	1.06	3.95	1.23	1.48	11	21
	612.604	●	●	●	0.09	0.06	0.41	0.60	0.85	1.04	1.34	4.98	1.54	1.86	11	21
	612.644	●	●	●	0.10	0.063	0.52	0.76	1.08	1.32	1.70	6.33	1.96	2.36	11	21
	612.674	●	●	●	0.11	0.07	0.63	0.89	1.25	1.54	1.98	7.51	2.35	2.81	11	22
	612.724	●	●	●	0.12	0.08	0.82	1.20	1.69	2.07	2.68	9.96	3.09	3.72	11	22
	612.764	●	●	●	0.14	0.09	1.04	1.52	2.15	2.63	3.40	12.65	3.92	4.73	11	22
612.804	●	●	●	0.16	0.10	1.30	1.90	2.69	3.29	4.25	15.81	4.90	5.91	11	23	
612.884	●	●	●	0.20	0.13	2.08	3.04	4.30	5.26	6.80	25.30	7.85	9.45	11	23	
75°	612.145	●		●	0.008	0.004	–	0.01*	0.014	0.017	0.021	0.08	0.025	0.03	15	27
	612.165	●		●	0.008	0.005	–	0.01*	0.017	0.02	0.027	0.10	0.03	0.04	15	27
	612.185	●		●	0.008	0.006	–	0.011*	0.02	0.03	0.035	0.13	0.04	0.05	15	27
	612.215	●		●	0.016	0.008	–	0.02*	0.03	0.04	0.05	0.18	0.06	0.07	15	27
	612.245	●		●	0.02	0.012	–	0.03*	0.04	0.05	0.07	0.26	0.08	0.10	15	27
612.275	●		●	0.024	0.012	0.03*	0.04	0.06	0.07	0.09	0.35	0.11	0.13	15	27	
90°	612.216	●		●	0.016	0.008	–	0.02*	0.03	0.04	0.05	0.18	0.06	0.07	17	31
	612.276	●		●	0.024	0.012	0.03*	0.04*	0.06	0.07	0.09	0.35	0.11	0.13	17	31
	612.306	●	●	●	0.03	0.016	0.04*	0.06*	0.09	0.11	0.14	0.51	0.16	0.19	17	31
	612.336	●	●	●	0.035	0.02	0.06*	0.09*	0.12	0.15	0.19	0.71	0.22	0.27	17	32
	612.366	●	●	●	0.04	0.028	0.08*	0.12*	0.17	0.21	0.27	1.00	0.31	0.37	18	33
	612.406	●	●	●	0.047	0.03	0.13*	0.19	0.27	0.33	0.42	1.58	0.49	0.59	18	33
	612.446	●	●	●	0.05	0.03	0.16*	0.24	0.34	0.41	0.53	1.98	0.61	0.74	18	34
	612.486	●	●	●	0.06	0.03	0.21*	0.30	0.43	0.53	0.68	2.53	0.78	0.95	19	34
	612.516	●	●	●	0.065	0.035	0.25*	0.36	0.51	0.62	0.81	3.00	0.93	1.12	19	35
	612.566	●	●	●	0.08	0.04	0.33	0.47	0.66	0.81	1.04	3.95	1.23	1.48	19	35
	612.606	●	●	●	0.09	0.047	0.41	0.60	0.85	1.04	1.34	4.98	1.54	1.86	20	36
	612.646	●	●	●	0.10	0.05	0.52	0.76	1.08	1.32	1.70	6.33	1.96	2.36	20	37
	612.676	●	●	●	0.11	0.06	0.62	0.90	1.28	1.56	2.02	7.51	2.33	2.81	20	37
	612.726	●	●	●	0.12	0.067	0.82	1.20	1.69	2.07	2.68	9.96	3.09	3.72	20	39
	612.766	●	●	●	0.14	0.07	1.04	1.52	2.15	2.63	3.40	12.65	3.92	4.73	21	39
612.806	●	●	●	0.16	0.09	1.30	1.90	2.69	3.29	4.25	15.81	4.90	5.91	21	41	

* Differing spray pattern.

¹ We reserve the right to supply material 316Ti or 316L under material no. 17.

NPT version available by request

Spray angle	Ordering number				Equivalent bore diameter A [in]	Narrowest free cross section Ø [in]	V̇ water [gal/min]								Spray width B [in] (at p = 75 psi)	
	Type	Material number					p [psi]								H = 10 [in]	H = 20 [in]
		16	17 ¹	30			liters per minute	5 bar	100	145	100	145	100	145		
		Stainless steel 303	Stainless steel 316Ti/ Stainless steel 316L	Brass												
120°	612.187	●		●	0.014	0.008	–	0.011*	0.02	0.03	0.035	0.13	0.04	0.05	25	42
	612.217	●		●	0.016	0.008	–	0.02*	0.03	0.04	0.05	0.18	0.06	0.07	26	43
	612.247	●		●	0.02	0.008	–	0.03*	0.04	0.05	0.07	0.26	0.08	0.10	26	43
	612.277	●		●	0.024	0.012	0.03*	0.04*	0.06	0.07	0.09	0.35	0.11	0.13	26	45
	612.307	●		●	0.03	0.012	0.04*	0.06*	0.09	0.11	0.14	0.51	0.16	0.19	28	49
	612.337	●	●	●	0.035	0.016	0.06*	0.09*	0.12	0.15	0.19	0.71	0.22	0.27	29	53
	612.367	●	●	●	0.04	0.016	0.08*	0.12*	0.17	0.21	0.27	1.00	0.31	0.37	31	56
	612.407	●	●	●	0.047	0.02	0.13*	0.19	0.27	0.33	0.42	1.58	0.49	0.59	33	58
	612.447	●	●	●	0.05	0.02	0.16*	0.24	0.34	0.41	0.53	1.98	0.61	0.74	33	60
	612.487	●	●	●	0.06	0.02	0.21*	0.30	0.43	0.53	0.68	2.53	0.78	0.95	33	61
	612.517	●	●	●	0.065	0.035	0.25*	0.36	0.51	0.62	0.81	3.00	0.93	1.12	33	61
	612.567	●	●	●	0.08	0.035	0.32	0.47	0.67	0.82	1.06	3.95	1.23	1.48	34	63
	612.607	●	●	●	0.09	0.04	0.41	0.60	0.85	1.04	1.34	4.98	1.54	1.86	34	64
	612.647	●	●	●	0.10	0.05	0.52	0.76	1.08	1.32	1.70	6.33	1.96	2.36	35	65
	612.677	●	●	●	0.11	0.06	0.62	0.90	1.28	1.56	2.02	7.51	2.33	2.81	35	65
612.727	●	●	●	0.12	0.063	0.82	1.20	1.69	2.07	2.68	9.96	3.09	3.72	35	66	
612.767	●	●	●	0.14	0.07	1.04	1.52	2.15	2.63	3.40	12.65	3.92	4.73	35	67	
612.807	●		●	0.16	0.08	1.30	1.90	2.69	3.29	4.25	15.81	4.90	5.91	35	67	

* Differing spray pattern.

¹ We reserve the right to supply material 316Ti or 316L under material no. 17.
NPT version available by request

Conversion formula for this series: $\dot{V}_2 = \dot{V}_1 \cdot \sqrt{\frac{p_2}{p_1}}$

Ordering Type + Material no. = Ordering no.
example: 612.187 + 16 = 612.187.16



Assembly accessories can be found in Chapter 12 "Accessories".

Low pressure flat fan nozzles

Series 616/617

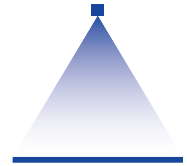

Features:

- Uniform, parabolic liquid distribution
- Stable spray angle
- Compact design for narrow installation conditions



Series 616/617

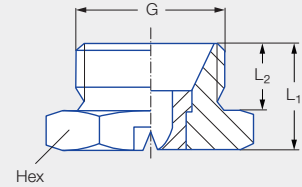

Applications:

- Spray cleaning
- Surface cleaning
- Filter cleaning
- Coating processes
- Belt cleaning
- Lubrication processes

G	Dimensions [mm]			Weight [in] Brass
	L ₁	L ₂	Hex (mm)	
3/4 BSPP	0.75	0.47	32	0.17

Spray angle	Ordering number				Equivalent bore diameter A [in]	Narrowest free cross section Ø [in]	V̇ water [gal/min]										Spray width B [in] (at p = 75 psi)	
	Type	Material number					p [psi]											
		16	17 ¹	30			7	15	30	45	75	liters per minute 5 bar	100	145	H = 10 [in]	H = 20 [in]		
20°	616.721	●	●	●	0.12	0.10	0.82	1.20	1.69	2.07	2.68	9.96	3.09	3.72	4	7		
	616.801	●	●	●	0.16	0.13	1.30	1.90	2.69	3.29	4.25	15.81	4.90	5.91	4	7		
	616.881	●	●	●	0.20	0.16	2.08	3.04	4.30	5.26	6.80	25.30	7.85	9.45	4	7		
	616.921	●	●	●	0.22	0.17	2.60	3.80	5.37	6.58	8.49	31.62	9.81	11.81	4	7		
	616.961	●	●	●	0.24	0.20	3.24	4.75	6.72	8.23	10.62	39.53	12.26	14.77	4	7		
30°	616.722	●	●	●	0.12	0.10	0.82	1.20	1.69	2.07	2.68	9.96	3.09	3.72	6	10		
	616.762	●	●	●	0.14	0.11	1.04	1.52	2.15	2.63	3.40	12.65	3.40	4.73	6	10		
	616.802	●	●	●	0.16	0.12	1.30	1.90	2.69	3.29	4.25	15.81	4.90	5.91	6	10		
	616.882	●	●	●	0.20	0.16	2.08	3.04	4.30	5.26	6.80	25.30	7.85	9.45	6	11		
	616.922	●	●	●	0.22	0.17	2.60	3.80	5.37	6.58	8.49	31.62	9.81	11.81	6	11		
616.962	●	●	●	0.24	0.20	3.24	4.75	6.72	8.23	10.62	39.53	12.26	14.77	6	11			
45°	616.723	●	●	●	0.12	0.09	0.82	1.20	1.69	2.07	2.68	9.96	3.09	3.72	9	17		
	616.763	●	●	●	0.14	0.10	1.04	1.52	2.15	2.63	3.40	12.65	3.40	4.73	9	17		
	616.803	●	●	●	0.16	0.12	1.30	1.90	2.69	3.29	4.25	15.81	4.90	5.91	9	17		
	616.843	●	●	●	0.18	0.13	1.62	2.37	3.36	4.11	5.31	19.76	6.13	7.38	9	17		
	616.883	●	●	●	0.20	0.15	2.08	3.04	4.30	5.26	6.80	25.30	7.85	9.45	9	17		
	616.923	●	●	●	0.22	0.165	2.60	3.80	5.37	6.58	8.49	31.62	9.81	11.81	9	17		
	616.963	●	●	●	0.24	0.17	3.24	4.75	6.72	8.23	10.62	39.53	12.26	14.77	9	17		

¹ We reserve the right to supply material 316Ti or 316L under material no. 17. Available in NPT upon request

Spray angle	Ordering number				Equivalent bore diameter A [in]	Narrowest free cross section Ø [in]	V̇ water [gal/min]								Spray width B [in] (at p = 75 psi)	
	Type	Material number					p [psi]									
		16	17 ¹	30												
		Stainless steel 303	Stainless steel 316Ti/ Stainless steel 316L	Brass			7	15	30	45	75	liters per minute 5 bar	100	145	H = 10 [in]	H = 20 [in]
60°	616.724	●	●	●	0.12	0.08	0.82	1.20	1.69	2.07	2.68	9.96	3.09	3.72	11	22
	616.764	●	●	●	0.14	0.09	1.04	1.52	2.15	2.63	3.40	12.65	3.40	4.73	11	22
	616.804	●	●	●	0.16	0.10	1.30	1.90	2.69	3.29	4.25	15.81	4.90	5.91	11	23
	616.844	●	●	●	0.18	0.12	1.62	2.37	3.36	4.11	5.31	19.76	6.13	7.38	11	23
	616.884	●	●	●	0.20	0.13	2.08	3.04	4.30	5.26	6.80	25.30	7.85	9.45	11	23
	616.924	●	●	●	0.22	0.16	2.60	3.80	5.37	6.58	8.49	31.62	9.81	11.81	11	23
	616.964	●	●	●	0.24	0.17	3.24	4.75	6.72	8.23	10.62	39.53	12.26	14.77	11	23
	617.044	●		●	0.31	0.22	5.19	7.59	10.74	13.15	16.98	63.20	19.61	23.61	11	23
617.124			●	0.39	0.29	8.17	11.97	16.92	20.73	26.76	99.60	30.90	37.21	11	23	
90°	616.726	●	●	●	0.12	0.07	0.82	1.20	1.69	2.07	2.68	9.96	3.09	3.72	20	39
	616.766	●	●	●	0.14	0.075	1.04	1.52	2.15	2.63	3.40	12.65	3.40	4.73	21	39
	616.806	●	●	●	0.16	0.09	1.30	1.90	2.69	3.29	4.25	15.81	4.90	5.91	21	41
	616.846	●	●	●	0.18	0.09	1.62	2.37	3.36	4.11	5.31	19.76	6.13	7.38	21	41
	616.886	●	●	●	0.20	0.12	2.08	3.04	4.30	5.26	6.80	25.30	7.85	9.45	21	42
	616.926	●	●	●	0.22	0.14	2.60	3.80	5.37	6.58	8.49	31.62	9.81	11.81	21	42
	616.966	●	●	●	0.24	0.15	3.24	4.75	6.72	8.23	10.62	39.53	12.26	14.77	21	42
120°	616.727	●	●	●	0.12	0.06	0.82	1.20	1.69	2.07	2.68	9.96	3.09	3.72	35	66
	616.767	●	●	●	0.14	0.07	1.04	1.52	2.15	2.63	3.40	12.65	3.40	4.73	35	67
	616.807	●	●	●	0.16	0.08	1.30	1.90	2.69	3.29	4.25	15.81	4.90	5.91	35	67
	616.887	●	●	●	0.20	0.10	1.62	2.37	3.36	4.11	5.31	19.76	6.13	7.38	36	67
	616.927	●	●	●	0.22	0.11	2.60	3.80	5.37	6.58	8.49	31.62	9.81	11.81	36	67
	616.967			●	0.24	0.13	3.24	4.75	6.72	8.23	10.62	39.53	12.26	14.77	36	67
	617.047			●	0.31	0.17	5.19	7.59	10.74	13.15	16.98	63.20	19.61	23.61	36	67

¹ We reserve the right to supply material 316Ti or 316L under material no. 17.
Available in NPT upon request

Conversion formula for this series: $\dot{V}_2 = \dot{V}_1 \cdot \sqrt{\frac{p_2}{p_1}}$

Ordering Type + Material no. = Ordering no.
example: 616.724 + 16 = 616.724.16



Assembly accessories can be found in Chapter 12 "Accessories".

Low pressure flat fan nozzles

Press-in nozzle

Series 612.xxx.5E.03

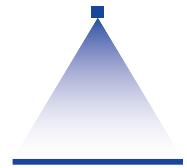

Features:

- Uniform, parabolic liquid distribution
- For pressing into pipes

Applications:

- Cleaning and rinsing procedures
- Industrial dish washers



Series 612.xxx.5E.03

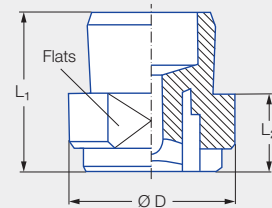

Dimensions [in]				Weight [g]
L ₁	L ₂	Ø D	Flats (mm)	
.49	.22	.55	12	.004

Spray angle	Ordering number		Equivalent bore diameter A [in]	Narrowest free cross section Ø [in]	V̇ water [gal/min]							Spray width B [in] (at p = 30 psi)	
	Type	Material number			p [psi]								
		5E.03			4	7	10	15	22	30	liters per minute		
		P.V.D.F.									2 bar		
90°	612.366	●	0.04	0.20	0.06	0.08	0.10	0.12	0.14	0.17	0.63	14	29
	612.486	●	0.06	0.203	0.16	0.21	0.25	0.30	0.37	0.43	1.60	14	29
120°	612.487	●	0.06	0.203	0.16	0.21	0.25	0.30	0.37	0.43	1.60	28	50
	612.647	●	0.10	0.50	0.40	0.52	0.62	0.76	0.92	1.08	4.00	28	50

Assembly :

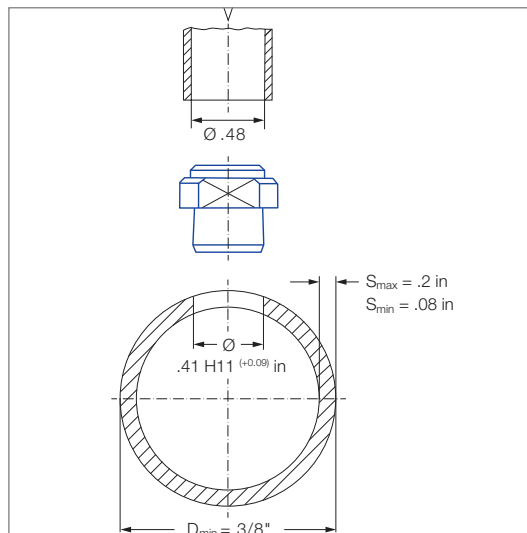

Drill pipe (Ø .4 in), ream to Ø .4 H11 (+0.09) in, adjust nozzle, place press-in pipe (inner diameter .48 in) on nozzle and tap in using a rubber mallet. Max. flow velocity in the pipe 2–3 m/s.

Conversion formula for this series: $\dot{V}_2 = \dot{V}_1 \cdot \sqrt{\frac{p_2}{p_1}}$

Ordering Type + Material no. = Ordering no.
example: 612.366 + 5E.03 = 612.366.5E.03



Assembly accessories can be found in Chapter 12 "Accessories".

Flat Fan Nozzle Tips

Series 672/673

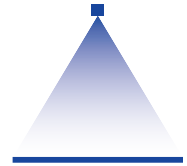

Features:

- Socket alignment flats

Applications:

- Cooling
- Lubricating



Series 672/673

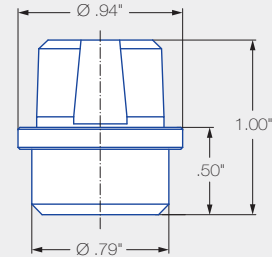

Nozzle Angle	Ordering number	Width—in. (B)	
		10°	20°
20°	672.561-672.921	3	7
	672.961-673.121	4	8
30°	672.562-672.962	5	11
	673.012-673.122	6	12
45°	672.563-672.963	8	17
	672.013-673.123	9	19
60°	672.564-673.124	13	25
90°	672.566-672.766	18	34
	672.806-672.886	19	36
	672.926-672.966	21	40
	673.016		
140°	672.567-672.677	27	51
	672.727	29	54
	672.767	30	55
	672.807-672.927	31	57
	673.047-673.127	49	85

Ordering number						Equivalent bore diameter (in.)	V̇ water [gal/min]									
Type							16	17 ¹	30	p [psi]						
Spray Angle										10 psi	20 psi	liters per minute 2 bar	40 psi	60 psi	80 psi	100 psi
20°	30°	45°	60°	90°	120°	303 SS	316 SS	Brass								
672.561	672.562	672.563	672.564	672.566	672.567	-	●	-	.079	.39	.55	2.5	.78	.95	1.1	1.2
672.601	672.602	672.603	672.604	672.606	672.607	-	●	-	.087	.49	.69	3.2	.98	1.2	1.4	1.5
672.641	672.642	672.643	672.644	672.646	672.647	-	●	-	.099	.62	.88	4	1.24	1.52	1.75	1.96
672.671	672.672	672.673	672.674	672.676	672.677	-	●	-	.106	.74	1.04	4.75	1.47	1.80	2.08	2.33
672.721	672.722	672.723	672.724	672.726	672.727	-	●	-	.118	.98	1.38	6.3	1.95	2.39	2.76	3.09
672.761	672.762	672.763	672.764	672.766	672.767	-	●	-	.137	1.24	1.75	8	2.48	3.04	3.51	3.92
672.801	672.802	672.803	672.804	672.806	672.807	-	●	-	.157	1.55	2.19	10	3.10	3.80	4.39	4.90
672.841	672.842	672.843	672.844	672.846	672.847	-	●	-	.177	1.94	2.75	12.5	3.88	4.75	5.48	6.13
672.881	672.882	672.883	672.884	672.886	672.887	-	●	-	.197	2.48	3.51	16	4.96	6.08	7.02	7.85
672.921	672.922	672.923	672.924	672.926	672.927	-	●	-	.220	3.10	4.39	20	6.20	7.60	8.77	9.81
672.961	672.962	672.963	672.964	673.016		-	●	-	.236	3.88	5.48	25	7.75	9.50	10.9	12.2
673.041	673.042	673.043	673.044	673.046	673.047	●	-	●	.315	6.20	8.77	40	12.4	15.2	17.5	19.6
673.081	673.082	673.083	673.084	673.086		●	-	●	.354	7.75	10.9	50	15.5	18.9	21.9	24.5
673.121	673.122	673.123	673.124	673.126	673.127	●	-	●	.394	9.77	13.8	63	19.5	23.9	27.6	30.9

¹ We reserve the right to supply material 316Ti or 316L under material no. 17.

Conversion formula for this series: $\dot{V}_2 = \dot{V}_1 \cdot \sqrt{\frac{P_2}{P_1}}$

Ordering	Type	+	Material no.	=	Ordering no.
example:	672.721	+	17	=	672.721.17

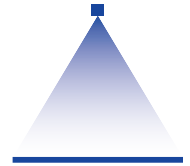

Series 672/673 bases, caps and accessories

Ordering number		Description	Material No.	
			17 ¹	30
Type			316 SS	Brass
Bases	067. 210. xx. 01	Weld Base, 1.06" long	●	
	067. 210. xx. 02	Weld Base, 1.37" long	●	
	067. 210. xx. 03	Weld Base, 1.67" long	●	
	067. 211. xx. 04	Weld Base, 2.37" long	●	
	067. 211. xx. 06	Weld Base, 4.92" long	●	
	067. 211. xx. 11	Weld Base, 7.08" long	●	
	067. 211. xx. 13	Weld Base, 3.94" long	●	
	067. 216. xx. BK	Threaded, 3/4" NPT Male, 1.75" long	●	
Caps	065. 600. xx. 00	Nozzle Tip Retainer Cap	●	●
Accessories	006. 721. xx. 00	Alignment Tip — Right Hand		●
	006. 722. xx. 00	Alignment Tip — Left Hand		●
	006. 723. xx. 00	Alignment Tip — Center		●

¹ We reserve the right to supply material 316Ti or 316L under material no. 17.
 Other base options are available.
 Please contact Lechler for more information.

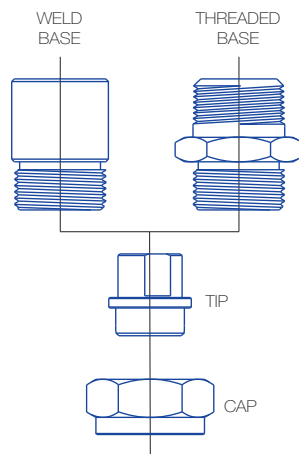

Low pressure flat fan nozzles for retaining nut

Series 652

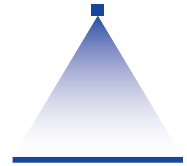

Features:

- Uniform, parabolic liquid distribution
- Stable spray angle
- Assembly with retaining nut

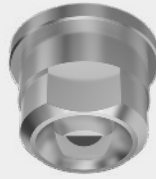

Series 652

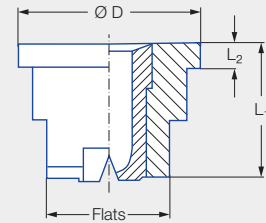

Applications:

- Spray cleaning
- Surface cleaning
- Filter cleaning
- Coating processes
- Belt cleaning
- Lubrication processes

Connection	Dimensions [in]				Weight [lb] Brass
	L ₁	L ₂	Ø D	Flats (mm)	
Assembly with retaining nut 3/8 BSPP	0.43	0.08	0.58	10	.02

Spray angle	Ordering number					Equivalent bore diameter A [in]	Narrowest free cross section Ø [in]	V̇ water [gal/min]								Spray width B [in] (at p = 75 psi)	
	Type	Material number						p [psi]									
		16	17 ¹	30	5E												
		Stainless steel 303	Stainless steel 316Ti/ Stainless steel 316L	Brass	PVDF			7	15	30	45	75	liters per minute 5 bar	145	H = 10 [in]	H = 20 [in]	
20°	652.301	●	●	●	●	0.03	0.02	0.04*	0.06*	0.09	0.11	0.14	0.51	0.19	3	6	
	652.361	●	●	●	●	0.04	0.03	0.08*	0.12*	0.17	0.21	0.27	1.00	0.37	3	6	
	652.441	●	●	●	●	0.05	0.04	0.16*	0.24	0.34	0.41	0.53	1.98	0.74	3	6	
	652.481	●	●	●	●	0.06	0.05	0.21*	0.30	0.43	0.53	0.68	2.53	0.95	3	6	
30°	652.302	●	●	●	●	0.02	0.02	0.04*	0.06*	0.08	0.11	0.13	0.51	0.19	5	9	
	652.362	●	●	●	●	0.04	0.03	0.08*	0.12*	0.17	0.21	0.27	1.00	0.37	5	9	
	652.402	●	●	●	●	0.05	0.035	0.13*	0.19	0.27	0.33	0.42	1.58	0.59	5	9	
	652.482	●	●	●	●	0.06	0.04	0.21*	0.30	0.43	0.53	0.68	2.53	0.95	5	9	
	652.562	●	●	●	●	0.08	0.06	0.32	0.47	0.67	0.82	1.06	3.95	1.48	5	9	
	652.642	●	●	●		0.10	0.07	0.52	0.76	1.08	1.32	1.70	6.33	2.36	6	10	
	652.722	●	●	●		0.12	0.09	0.82	1.20	1.69	2.07	2.68	9.96	3.72	6	10	
	652.762	●	●	●		0.14	0.11	1.04	1.52	2.15	2.63	3.40	12.65	4.73	6	10	
652.802	●	●	●		0.16	0.12	1.30	1.90	2.69	3.29	4.25	15.81	5.91	6	10		
45°	652.303	●	●	●		0.03	0.02	0.04*	0.06*	0.08	0.11	0.13	0.51	0.19	7	13	
	652.363	●	●	●	●	0.04	0.024	0.08*	0.12*	0.17	0.21	0.27	1.00	0.37	7	14	
	652.403	●	●	●	●	0.05	0.035	0.13*	0.19	0.27	0.33	0.42	1.58	0.59	8	15	
	652.483	●	●	●	●	0.06	0.04	0.21*	0.30	0.43	0.53	0.68	2.53	0.95	8	15	
	652.563	●	●	●	●	0.08	0.06	0.32	0.47	0.67	0.82	1.06	3.95	1.48	8	16	
	652.643	●	●	●	●	0.10	0.07	0.52	0.76	1.08	1.32	1.70	6.33	2.36	9	16	
	652.723	●	●	●		0.12	0.09	0.82	1.20	1.69	2.07	2.68	9.96	3.72	9	17	
	652.763	●	●	●		0.14	0.10	1.04	1.52	2.15	2.63	3.40	12.65	4.73	9	17	
	652.803	●	●	●		0.16	0.12	1.30	1.90	2.69	3.29	4.25	15.81	5.91	9	17	

* Differing spray pattern.

¹ We reserve the right to supply material 316Ti or 316L under material no. 17.

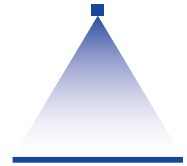

Spray angle	Ordering number					Equivalent bore diameter A [in]	Narrowest free cross section Ø [in]	V̇ water [gal/min]							Spray width B [in] (at p = 75 psi)	
	Type	Material number						p [psi]							H = 10 [in]	H = 20 [in]
		16	17 ¹	30	5E			liters per minute 5 bar	145	7	15	30	45	75		
		Stainless steel 303	Stainless steel 316Ti/ Stainless steel 316L	Brass	PVDF											
60°	652.304	●	●	●	●	0.03	0.016	0.04*	0.06	0.09	0.11	0.14	0.51	0.19	10	19
	652.334	●	●	●	●	0.035	0.02	0.06*	0.09	0.12	0.15	0.19	0.71	0.27	10	19
	652.364	●	●	●	●	0.04	0.024	0.08*	0.12	0.17	0.21	0.27	1.00	0.37	10	20
	652.404	●	●	●	●	0.047	0.03	0.13*	0.19	0.27	0.33	0.42	1.58	0.59	10	20
	652.444	●	●	●	●	0.05	0.035	0.16*	0.24	0.34	0.41	0.53	1.98	0.74	10	20
	652.484	●	●	●	●	0.06	0.04	0.21*	0.30	0.43	0.53	0.68	2.53	0.95	10	20
	652.514	●	●	●	●	0.065	0.043	0.25*	0.36	0.51	0.62	0.81	3.00	1.12	11	20
	652.564	●	●	●	●	0.08	0.05	0.32	0.47	0.67	0.82	1.06	3.95	1.48	11	21
	652.604	●	●	●	●	0.09	0.06	0.41	0.60	0.85	1.04	1.34	4.98	1.86	11	21
	652.644	●	●	●	●	0.10	0.063	0.52	0.76	1.08	1.32	1.70	6.33	2.36	11	21
	652.674	●	●	●	●	0.11	0.07	0.62	0.90	1.28	1.56	2.02	7.51	2.81	11	22
	652.724	●	●	●	●	0.12	0.08	0.82	1.20	1.69	2.07	2.68	9.96	3.72	11	22
	652.764	●	●	●	●	0.14	0.09	1.04	1.52	2.15	2.63	3.40	12.65	4.73	11	22
	652.804	●	●	●	●	0.16	0.10	1.30	1.90	2.69	3.29	4.25	15.81	5.91	11	23
652.844	●	●	●	●	0.18	0.12	1.62	2.37	3.36	4.11	5.31	19.76	7.38	11	23	
652.884	●	●	●	●	0.20	0.13	2.08	3.04	4.30	5.26	6.80	25.30	9.45	11	23	
75°	652.145	●	●	●	●	0.008	0.004	–	0.01*	0.014	0.017	0.021	0.08	0.03	15	27
	652.165	●	●	●	●	0.008	0.005	–	0.01*	0.017	0.02	0.027	0.10	0.04	15	27
	652.185	●	●	●	●	0.008	0.006	–	0.011*	0.02	0.03	0.035	0.13	0.05	15	27
	652.215	●	●	●	●	0.016	0.008	–	0.02*	0.03	0.04	0.05	0.18	0.07	15	27
	652.245	●	●	●	●	0.02	0.012	–	0.03*	0.04	0.05	0.07	0.26	0.10	15	27
	652.275	●	●	●	●	0.024	0.012	0.03*	0.04*	0.06	0.07	0.09	0.35	0.13	15	27
90°	652.216	●	●	●	●	0.016	0.008	0.01*	0.02*	0.03	0.04	0.05	0.18	0.07	17	31
	652.246	●	●	●	●	0.02	0.012	0.02*	0.03*	0.04	0.05	0.07	0.26	0.10	17	31
	652.276	●	●	●	●	0.024	0.012	0.03*	0.04*	0.06	0.07	0.09	0.35	0.13	17	31
	652.306	●	●	●	●	0.03	0.016	0.04*	0.06*	0.09	0.11	0.14	0.51	0.19	17	31
	652.336	●	●	●	●	0.035	0.02	0.06*	0.09*	0.12	0.15	0.19	0.71	0.27	17	32
	652.366	●	●	●	●	0.04	0.02	0.08*	0.12	0.17	0.21	0.27	1.00	0.37	18	33
	652.406	●	●	●	●	0.047	0.028	0.13*	0.19	0.27	0.33	0.42	1.58	0.59	18	33
	652.446	●	●	●	●	0.05	0.03	0.16*	0.24	0.34	0.41	0.53	1.98	0.74	18	34
	652.486	●	●	●	●	0.06	0.03	0.21*	0.30	0.43	0.53	0.68	2.53	0.95	19	34
	652.516	●	●	●	●	0.065	0.035	0.25*	0.36	0.51	0.62	0.81	3.00	1.12	19	35
	652.566	●	●	●	●	0.08	0.04	0.32	0.47	0.67	0.82	1.06	3.95	1.48	19	35
	652.606	●	●	●	●	0.09	0.047	0.41	0.60	0.85	1.04	1.34	4.98	1.86	20	36
	652.646	●	●	●	●	0.10	0.05	0.52	0.76	1.08	1.32	1.70	6.33	2.36	20	37
	652.676	●	●	●	●	0.11	0.06	0.62	0.90	1.28	1.56	2.02	7.51	2.81	20	37
	652.726	●	●	●	●	0.12	0.07	0.82	1.20	1.69	2.07	2.68	9.96	3.72	20	39
	652.766	●	●	●	●	0.14	0.075	1.04	1.52	2.15	2.63	3.40	12.65	4.73	21	39
	652.806	●	●	●	●	0.16	0.09	1.30	1.90	2.69	3.29	4.25	15.81	5.91	21	41
	652.846	●	●	●	●	0.18	0.09	1.62	2.37	3.36	4.11	5.31	19.76	7.38	21	41
652.886	●	●	●	●	0.20	0.12	2.08	3.04	4.30	5.26	6.80	25.30	9.45	21	42	

Conversion formula for this series: $\dot{V}_2 = \dot{V}_1 \cdot \sqrt{\frac{p_2}{p_1}}$

* Differing spray pattern.

¹ We reserve the right to supply material 316Ti or 316L under material no. 17.



Ordering	Type	+	Material no.	=	Ordering no.
example:	652. 216	+	16	=	652. 216. 16

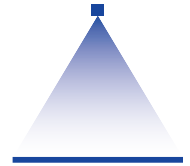

Spray angle	Ordering number					Equivalent bore diameter A [in]	Narrowest free cross section Ø [in]	V̇ water [gal/min]							Spray width B [in] (at p = 75 psi)	
	Type	Material number						p [psi]								
		16	17 ¹	30	5E			7	15	30	45	75	liters per minute 5 bar	145		
120°	652.187	●		●		0.01	0.008	–	0.011*	0.02	0.03	0.035	0.13	0.05	25	42
	652.217	●		●		0.016	0.008	–	0.02*	0.03	0.04	0.05	0.18	0.07	26	43
	652.247	●		●		0.02	0.008	–	0.03*	0.04	0.05	0.07	0.26	0.10	26	43
	652.277	●		●		0.024	0.012	–	0.04*	0.06	0.07	0.09	0.35	0.13	26	45
	652.307	●		●	●	0.03	0.012	0.04*	0.06*	0.09	0.11	0.14	0.51	0.19	28	49
	652.337	●	●	●	●	0.035	0.016	0.06*	0.09*	0.12	0.15	0.19	0.71	0.27	29	53
	652.367	●	●	●	●	0.04	0.02	0.08*	0.12*	0.17	0.21	0.27	1.00	0.37	31	56
	652.407	●	●	●	●	0.047	0.024	0.13*	0.19	0.27	0.33	0.42	1.58	0.59	33	58
	652.447	●	●	●	●	0.05	0.024	0.16*	0.24	0.34	0.41	0.53	1.98	0.74	33	60
	652.487	●	●	●	●	0.06	0.024	0.21*	0.30	0.43	0.53	0.68	2.53	0.95	33	61
	652.517	●	●	●	●	0.065	0.035	0.25*	0.36	0.51	0.61	0.81	3.00	1.12	33	61
	652.567	●	●	●	●	0.08	0.04	0.32	0.47	0.67	0.82	1.06	3.95	1.48	34	63
	652.607	●	●	●	●	0.09	0.043	0.41	0.60	0.85	1.04	1.34	4.98	1.86	34	64
	652.647	●	●	●		0.10	0.05	0.52	0.76	1.08	1.32	1.70	6.33	2.36	35	65
	652.677	●	●	●		0.11	0.06	0.62	0.90	1.28	1.56	2.02	7.51	2.81	35	65
	652.727	●	●	●	●	0.12	0.063	0.82	1.20	1.69	2.07	2.68	9.96	3.72	35	66
	652.767	●	●	●		0.14	0.07	1.04	1.52	2.15	2.63	3.40	12.65	4.73	35	67
652.807	●		●		0.16	0.08	1.30	1.90	2.69	3.29	4.25	15.81	5.91	35	67	
652.847				●	0.18	0.09	1.62	2.37	3.36	4.11	5.31	19.76	7.38	35	67	
652.887				●	0.20	0.10	2.08	3.04	4.30	5.26	6.80	25.30	9.45	36	67	

* Differing spray pattern.

¹ We reserve the right to supply material 316Ti or 316L under material no. 17.

Assembly example

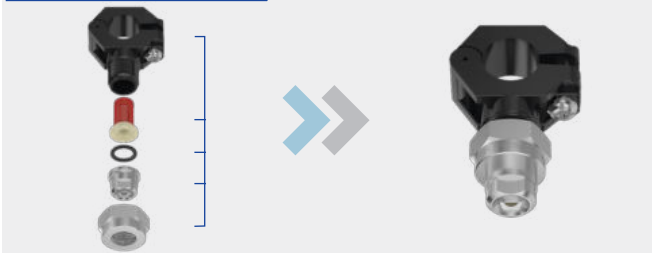

Bases and Caps for Mounting

Inlet NPT Male	Outlet Male	Part No.	Standard Materials: 17 316 SS 30 Brass
1/4" 3/8"	11/16 x 16 11/16 x 16	065. 215. XX. 10 065. 211. XX. 10	
1/4" 3/8"	3/8 BSPP 3/8 BSPP	065. 215. XX. 11 065. 215. XX. 12	
Caps			
To fit 11/16x16		069. 000. XX. 00	Other materials available. See Accessories beginning on page 127.
To fit 3/8 BSPP		065. 200. XX. 00	

Example Type + Material no. = Ordering no.
for ordering: 652. 407 + 30 = 652. 407. 30

Conversion formula for this series: $\dot{V}_2 = \dot{V}_1 \cdot \sqrt{\frac{p_2}{p_1}}$

Ordering Type + Material no. = Ordering no.
example: 652.187 + 16 = 652.187.16

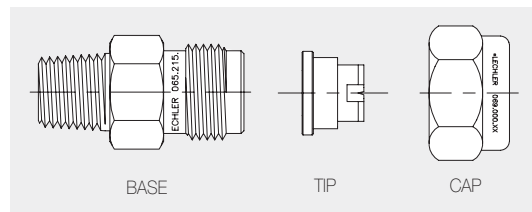

1) We reserve the right to deliver material 316 SS or 316L SS, if we show the material code 17.



Assembly accessories can be found in Chapter 12 "Accessories".

Low pressure flat fan nozzles for retaining nut

Series 656/657

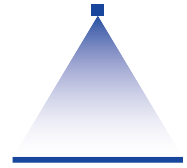

Features:

- Uniform, parabolic liquid distribution
- Stable spray angle
- High spray energy
- Assembly with retaining nut
- Non-clogging

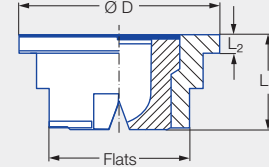

Series 656/657

Applications:

- Cleaning installations
- Gravel washing
- Roll cooling
- Cooling of rolled stock
- Cooling pipes

Connection	Dimensions [in]				Weight [lb] Brass
	L ₁	L ₂	Ø D	Flats (mm)	
Assembly with retaining nut 3/4 BSPP	.43	.08	.94	17	.05

Spray angle	Ordering number				Equivalent bore diameter A [in]	Narrowest free cross section Ø [in]	V̇ water [gal/min]								Spray width B [mm] (at p = 75 psi)	
	Type	Material number					p [psi]									
		16	17 ¹	30												
		Stainless steel 303	Stainless steel 316Ti/ Stainless steel 316L	Brass			7	15	30	45	75	liters per minute 5 bar	100	145	H = 10 [in]	H = 20 [in]
20°	656.721	●	●	●	0.12	0.10	0.82	1.20	1.69	2.07	2.68	9.96	3.09	3.72	4	7
	656.801	●	●	●	0.16	0.13	1.30	1.90	2.69	3.29	4.25	15.81	4.90	5.91	4	7
	656.881	●	●	●	0.20	0.16	2.08	3.04	4.30	5.26	6.80	25.30	7.85	9.45	4	7
	656.921	●	●	●	0.22	0.17	2.60	3.80	5.37	6.58	8.49	31.62	9.81	11.81	4	7
	656.961	●	●	●	0.24	0.21	3.24	4.75	6.72	8.23	10.62	39.53	12.26	14.77	4	7
30°	656.722	●	●	●	0.12	0.09	0.82	1.20	1.69	2.07	2.68	9.96	3.09	3.72	6	10
	656.762	●	●	●	0.14	0.11	1.04	1.52	2.15	2.63	3.40	12.65	3.92	4.73	6	10
	656.802	●	●	●	0.16	0.12	1.30	1.90	2.69	3.29	4.25	15.81	4.90	5.91	6	10
	656.882	●	●	●	0.20	0.16	2.08	3.04	4.30	5.26	6.80	25.30	7.85	9.45	6	11
	656.922	●	●	●	0.22	0.17	2.60	3.80	5.37	6.58	8.49	31.62	9.81	11.81	6	11
	656.962	●	●	●	0.24	0.20	3.24	4.75	6.72	8.23	10.62	39.53	12.26	14.77	6	11
45°	656.723	●	●	●	0.12	0.09	0.82	1.20	1.69	2.07	2.68	9.96	3.09	3.72	9	17
	656.763	●	●	●	0.14	0.10	1.04	1.52	2.15	2.63	3.40	12.65	3.92	4.73	9	17
	656.803	●	●	●	0.16	0.12	1.30	1.90	2.69	3.29	4.25	15.81	4.90	5.91	9	17
	656.843	●	●	●	0.18	0.13	1.62	2.37	3.36	4.11	5.31	19.76	6.13	7.38	9	17
	656.883	●	●	●	0.20	0.15	2.08	3.04	4.30	5.26	6.80	25.30	7.85	9.45	9	17
	656.923	●	●	●	0.22	0.165	2.60	3.80	5.37	6.58	8.49	31.62	9.81	11.81	9	17
	656.963	●	●	●	0.24	0.17	3.24	4.75	6.72	8.23	10.62	39.53	12.26	14.77	9	17

¹ We reserve the right to supply material 316Ti or 316L under material no. 17.



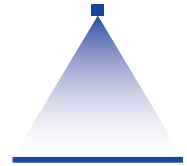

Spray angle	Ordering number				Equivalent bore diameter A [in]	Narrowest free cross section Ø [in]	V̇ water [gal/min]								Spray width B [mm] (at p = 75 psi)	
	Material number						p [psi]									
	16	17 ¹	30													
	Type	Stainless steel 303	Stainless steel 316Ti/ Stainless steel 316L	Brass			7	15	30	45	75	liters per minute 5 bar	100	145	H = 10 [in]	H = 20 [in]
60°	656.724	●	●	●	0.12	0.08	0.82	1.20	1.69	2.07	2.68	9.96	3.09	3.72	11	22
	656.764	●	●	●	0.14	0.09	1.04	1.52	2.15	2.63	3.40	12.65	3.92	4.73	11	22
	656.804	●	●	●	0.16	0.10	1.30	1.90	2.69	3.29	4.25	15.81	4.90	5.91	11	23
	656.844	●	●	●	0.18	0.12	1.62	2.37	3.36	4.11	5.31	19.76	6.13	7.38	11	23
	656.884	●	●	●	0.20	0.13	2.08	3.04	4.30	5.26	6.80	25.30	7.85	9.45	11	23
	656.924	●	●	●	0.22	0.16	2.60	3.80	5.37	6.58	8.49	31.62	9.81	11.81	11	23
	656.964	●	●	●	0.24	0.17	3.24	4.75	6.72	8.23	10.62	39.53	12.26	14.77	11	23
	657.044		●	●	0.31	0.22	5.19	7.60	10.75	13.16	16.99	63.25	19.62	23.63	11	23
90°	656.726	●	●	●	0.12	0.067	0.82	1.20	1.69	2.07	2.68	9.96	3.09	3.72	20	39
	656.766	●	●	●	0.14	0.075	1.04	1.52	2.15	2.63	3.40	12.65	3.92	4.73	21	39
	656.806	●	●	●	0.16	0.09	1.30	1.90	2.69	3.29	4.25	15.81	4.90	5.91	21	41
	656.846	●	●	●	0.18	0.09	1.62	2.37	3.36	4.11	5.31	19.76	6.13	7.38	21	41
	656.886	●	●	●	0.20	0.12	2.08	3.04	4.30	5.26	6.80	25.30	7.85	9.45	21	42
	656.926	●	●	●	0.22	0.14	2.60	3.80	5.37	6.58	8.49	31.62	9.81	11.81	21	42
	656.966	●	●	●	0.24	0.15	3.24	4.75	6.72	8.23	10.62	39.53	12.26	14.77	21	42
	657.046			●	0.31	0.19	5.19	7.60	10.75	13.16	16.99	63.25	19.62	23.63	21	42
120°	656.727	●	●	●	0.12	0.06	0.82	1.20	1.69	2.07	2.68	9.96	3.09	3.72	35	66
	656.767	●	●	●	0.14	0.07	1.04	1.52	2.15	2.63	3.40	12.65	3.92	4.73	35	67
	656.807	●	●	●	0.16	0.08	1.30	1.90	2.69	3.29	4.25	15.81	4.90	5.91	35	67
	656.887	●	●	●	0.20	0.10	2.08	3.04	4.30	5.26	6.80	25.30	7.85	9.45	11	67
	656.927	●	●	●	0.22	0.11	2.60	3.80	5.37	6.58	8.49	31.62	9.81	11.81	11	67

¹ We reserve the right to supply material 316Ti or 316L under material no. 17.

Inlet Male NPT	Outlet Male	Part No.	Standard Materials: 17 316 SS 30 Brass
3/4"	3/4" BSPP	065. 611. XX. BK	
Cap			Other materials available. See Accessories beginning on page 127.
To fit 3/4" BSPP		065. 600. XX. 00	

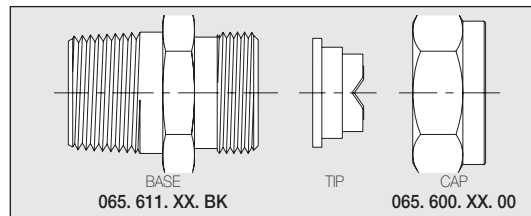

Example Type + Material no. = Ordering no.
for ordering: 656. 727 + 16 = 656. 727. 16

1) We reserve the right to deliver material 316 SS or 316L SS, if we show the material code 17.

Conversion formula for this series: $\dot{V}_2 = \dot{V}_1 \cdot \sqrt{\frac{p_2}{p_1}}$

Ordering Type + Material no. = Ordering no.
example: 656.724 + 16 = 656.724.16

Assembly accessories can be found in Chapter 12 "Accessories".

Low pressure tongue-type nozzles

Series 684

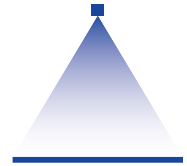

Features:

- Sharply delimited, powerful flat fan spray
- Large spray angle
- Assembly with retaining nut
- Non-clogging

Applications:

- Foam control
- Cleaning processes
- Washing processes



Series 684

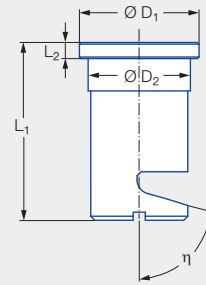

G	Dimensions [in]			Weight [lb]
	L ₂	Ø D ₁	Ø D ₂	
Assembly with retaining nut 3/8 NPT	0.08	0.58	0.50	0.01

Spray angle	Deflection angle η	Ordering number		Color ¹	Bore diameter B [in]	L ₁ [in]	V̇ water [gal/min]				Spray width B [in] (at p = 30 psi)	
		Type	Material number				p [psi]					
			56				5E	15	30	liters per minute 2 bar	75	H = 10 [in]
140°	75°	684.348	●		Green	0.028	0.79	0.09*	0.13	0.50	0.21	49
		684.368	●	●	Yellow	0.03	0.79	0.12*	0.17	0.63	0.27	49
		684.408	●		Blue	0.04	0.79	0.19	0.27	1.00	0.42	50
		684.448	●		Red	0.047	0.79	0.24	0.34	1.25	0.53	50
		684.488	●	●	Brown	0.05	0.79	0.30	0.43	1.60	0.68	50
		684.528	●		Grey	0.06	0.79	0.38	0.54	2.00	0.85	50
		684.568	●	●	White	0.07	0.75	0.47	0.67	2.50	1.06	51
		684.608	●		Light blue	0.075	0.75	0.60	0.85	3.15	1.34	51
		684.688	●		Green	0.09	0.67	0.95	1.34	5.00	2.12	52
		684.728	●	●	Black	0.11	0.67	1.20	1.69	6.30	2.68	53
684.808	●		Beige	0.13	0.63	1.90	2.69	10.00	4.25	53		

* Differing spray pattern.

¹ PVDF material is always blue.

Assembly example



Conversion formula for this series: $\dot{V}_2 = \dot{V}_1 \cdot \sqrt{\frac{p_2}{p_1}}$

Ordering Type + Material no. = Ordering no.
example: 684.348 + 56 = 684.348.56



Assembly accessories can be found in Chapter 12 "Accessories".

Low pressure tongue-type nozzles

Series 686

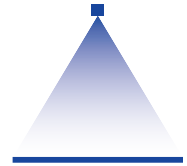

Features:

- Sharply delimited, powerful flat fan spray
- Large spray angle
- Non-clogging

Applications:

- Foam control
- Cleaning processes
- Washing processes



Series 686

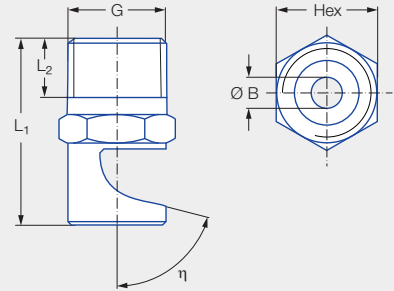

Type	NPT	Connection	Dimensions [in]			Weight [lb] Brass
			L ₁	L ₂	Hex	
686.366	1/8	BA	0.91	0.26	7/16	0.03
686.406	1/8	BA	0.91	0.26	7/16	0.03
686.686	1/4	BC	1.16	0.38	9/16	0.05
686.726	1/8	BA	0.98	0.26	7/16	0.03
686.806	1/4	BC	1.30	0.38	9/16	0.05
686.886	1/4	BC	1.38	0.38	9/16	0.07
686.926	3/8	BE	1.52	0.40	11/16	0.07
686.368	1/8	BA	0.79	0.26	7/16	0.03
686.408	1/8	BA	0.91	0.26	7/16	0.03
686.448	1/4	BC	0.94	0.38	9/16	0.05
686.488	1/8	BA	0.91	0.26	7/16	0.03
686.488	1/4	BC	0.94	0.38	9/16	0.05
686.528	1/8	BA	0.91	0.26	7/16	0.03
686.528	1/4	BC	0.94	0.38	9/16	0.05
686.568	1/8	BA	0.91	0.26	7/16	0.03
686.568	1/4	BC	0.94	0.38	9/16	0.05
686.608	1/8	BA	0.91	0.26	7/16	0.03
686.608	1/4	BC	0.94	0.38	9/16	0.05
686.648	1/4	BC	0.94	0.38	9/16	0.05
686.688	1/8	BA	0.91	0.26	7/16	0.03
686.688	1/4	BC	1.06	0.38	9/16	0.05
686.728	1/8	BA	0.91	0.26	7/16	0.03
686.728	1/4	BC	1.06	0.38	9/16	0.05
686.768	1/4	BC	1.06	0.38	9/16	0.05
686.808	1/8	BA	0.91	0.26	7/16	0.03
686.808	1/4	BC	1.06	0.38	9/16	0.05
686.828	1/4	BC	1.06	0.38	9/16	0.05
686.848	1/4	BC	1.06	0.38	9/16	0.05
686.868	1/4	BC	1.10	0.38	9/16	0.05
686.888	1/4	BC	1.10	0.38	9/16	0.05
686.908	1/4	BC	1.10	0.38	9/16	0.05
686.928	3/8	BE	1.18	0.40	11/16	0.07
686.968	1/2	BG	1.46	0.52	7/8	0.13
686.988	3/8	BE	1.26	0.40	11/16	0.07
686.988	1/2	BG	1.46	0.52	7/8	0.13

Also suitable for air or saturated steam (see Page 218).

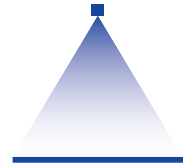

Spray angle	Deflection angle η	Ordering number								Bore diameter B [in]	V water [gal/min]					Spray width B [in] (at p = 30 psi)
		Material number			Connection				p [psi]							
		16	30	5E	1/8 NPT	1/4 NPT	3/8 NPT	1/2 NPT	15		20	30	liters per minute	75	H = 10 [in]	
		Type	Stainless steel 303	Brass									PVDF			2 bar
90°	75°	686.366		●		BA			0.03	0.12	0.14	0.17	0.63	0.26	18	
		686.406	●	●		BA			0.04	0.19	0.22	0.27	1.00	0.42	18	
	40°	686.686	●	●		BC			0.09	0.95	1.10	1.34	5.00	2.12	20	
		686.726		●		BA			0.11	1.20	1.38	1.69	6.30	2.68	21	
		686.806	●	●		BC			0.13	1.90	2.19	2.69	10.00	4.25	21	
		686.886	●			BC			0.17	3.04	3.51	4.30	16.00	6.80	21	
686.926	●					BE	0.19	3.80	4.39	5.37	20.00	8.50	21			
140°	75°	686.368	●	●		BA			0.03	0.12	0.14	0.17	0.63	0.26	49	
		686.408	●	●		BA			0.04	0.19	0.22	0.27	1.00	0.42	50	
		686.448	●	●			BC			0.047	0.24	0.27	0.34	1.25	0.53	50
		686.488	●	●		BA	BC			0.05	0.30	0.35	0.43	1.60	0.68	50
		686.528	●	●		BA	BC			0.06	0.38	0.44	0.54	2.00	0.85	50
		686.568	●	●	● ¹	BA	BC			0.07	0.47	0.55	0.67	2.50	1.06	51
		686.608	●	●		BA	BC			0.075	0.60	0.69	0.85	3.15	1.34	51
		686.648	●	●			BC			0.087	0.76	0.88	1.07	4.00	1.70	52
		686.688	●	●		BA	BC			0.09	0.95	1.10	1.34	5.00	2.12	52
		686.728	●	●		BA	BC			0.11	1.20	1.38	1.69	6.30	2.68	53
		686.768	●	●			BC			0.12	1.52	1.75	2.15	8.00	3.40	53
		686.808	●	●		BA	BC			0.13	1.90	2.19	2.69	10.00	4.25	54
		686.828	●	●			BC			0.14	2.13	2.46	3.01	11.20	4.76	54
		686.848	●	●			BC			0.15	2.37	2.74	3.36	12.50	5.31	54
		686.868	●	●			BC			0.16	2.66	3.07	3.76	14.00	5.95	54
		686.888	●	●			BC			0.17	3.04	3.51	4.30	16.00	6.80	54
		686.908	●	●			BC			0.18	3.42	3.95	4.84	18.00	7.65	54
		686.928	●					BE		0.19	3.80	4.39	5.37	20.00	8.50	54
686.968		●					BG	0.21	4.75	5.48	6.72	25.00	10.62	54		
686.988	●					BE	BG	0.22	5.32	6.14	7.52	28.00	11.89	54		

¹ Only available with code BA.

Conversion formula for this series: $\dot{V}_2 = \dot{V}_1 \cdot \sqrt{\frac{p_2}{p_1}}$

Ordering Type + Material no. + Code = Ordering no.
 example: 686.366 + 30 + BA = 686.366.30.BA



Assembly accessories can be found in Chapter 12 "Accessories".

Low pressure tongue-type nozzles

Series 688/689

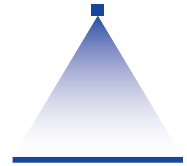

Features:

- Narrowly delimited, powerful flat fan spray
- Non-clogging

Applications:

- Cleaning processes
- Washing processes
- Degreasing installations
- Phosphating installations
- Preparation techniques

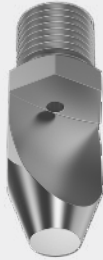

Series 688/689

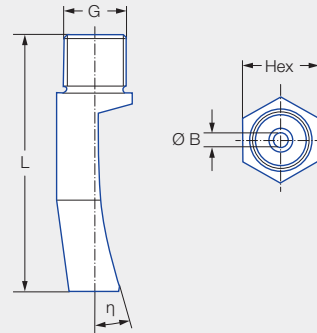

Type	Connection	G	Dimensions [in]		Weight [lb]
			L	Hex (mm)	
688.763	BE	3/8 NPT	1.69	19	0.18 (Stainless steel 303)
688.843	BE	3/8 NPT	1.97	19	0.29 (Stainless steel 303)
688.923	BE	3/8 NPT	2.32	22	0.55 (Stainless steel 303)
689.003	BK	3/4 NPT	3.15	32/24	0.68/0.07 (Stainless steel 303/PVDF)

Spray angle	Deflection angle η	Ordering number				Bore diameter B [in]	\dot{V} water [gal/min]					Spray width B [in] (at p = 30 psi)		
		Material number		Connection			p [psi]					 H = 10 [in] H = 20 [in]		
		16	5E				7	15	30	liters per minute 2 bar	75			
45°	35°	688.763	●		BE		0.12	1.04	1.52	2.15	8.00	3.40	9	17
	30°	688.843	●		BE		0.15	1.62	2.37	3.36	12.50	5.31	9	17
	29°	688.923	●		BE		0.19	2.60	3.80	5.37	20.00	8.50	9	17
	35°	689.003	●	●	BK		0.24	4.09	5.98	8.46	31.50	13.38	9	17

Conversion formula for this series: $\dot{V}_2 = \dot{V}_1 \cdot \sqrt{\frac{p_2}{p_1}}$

Ordering example: Type 688.763 + Material no. 16 + Code BE = Ordering no. 688.763.16.BE



Assembly accessories can be found in Chapter 12 "Accessories".

Threaded Disc type tips

Series 680

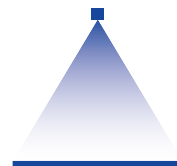

Features:

- Excellent for inexpensive headers with minimal clearance
- Orifices thread directly into pipe wall without any protrusion



Series 680

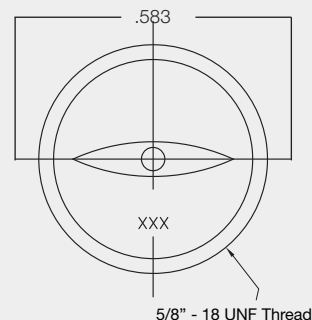

Applications:

- Belt washing
- Web coating
- Spray washing of products on conveyors

Spray angle at 40psi	Ordering number		Bore diameter (in.)	V̇ water [gal/min]								
	Type	Material		p [psi]								
		316 SS 17 ¹		10 psi	20 psi	30 psi	liters per minute 2 bar	40 psi	60 psi	80 psi	100 psi	150 psi
35°	680. 402	●	.046	-	0.22	0.27	1.00	0.31	0.38	0.44	0.49	0.60
	680. 492	●	.062	0.26	0.37	0.46	1.70	0.53	0.65	0.75	0.83	1.02
	680. 572	●	.076	0.40	0.57	0.70	2.60	0.81	0.99	1.14	1.28	1.56
	680. 712	●	.111	0.92	1.29	1.59	5.90	1.83	2.24	2.59	2.89	3.54
	680. 752	●	.125	1.19	1.69	2.07	7.70	2.39	2.93	3.38	3.78	4.63
	680. 872	●	.187	2.33	3.29	4.03	15.0	4.65	5.70	6.58	7.36	9.01
50°	680. 403	●	.046	-	0.22	0.27	1.00	0.31	0.38	0.44	0.49	0.60
	680. 493	●	.062	0.26	0.37	0.46	1.70	0.53	0.65	0.75	0.83	1.02
	680. 573	●	.076	0.40	0.57	0.70	2.60	0.81	0.99	1.14	1.28	1.56
	680. 713	●	.111	0.92	1.29	1.59	5.90	1.83	2.24	2.59	2.89	3.54
	680. 813	●	.156	1.61	2.28	2.79	10.4	3.23	3.95	4.56	5.10	6.25
	680. 873	●	.187	2.33	3.29	4.03	15.0	4.65	5.70	6.58	7.36	9.01
	680. 953	●	.218	3.52	4.98	6.10	22.7	7.04	8.62	9.96	11.13	13.64
	680. 993	●	.250	4.73	6.69	8.19	30.5	9.46	11.59	13.38	14.96	18.32
65°	680. 374**	●	.040	-	-	0.21	0.80	0.25	0.30	0.35	0.39	0.48
	680. 404	●	.046	-	0.22	0.28	1.00	0.32	0.40	0.47	0.52	0.65
	680. 494	●	.062	0.26	0.37	0.46	1.70	0.53	0.65	0.75	0.83	1.02
	680. 574*	●	.076	0.40	0.57	0.70	2.60	0.81	0.99	1.14	1.28	1.56
	680. 714	●	.111	0.92	1.29	1.59	5.90	1.83	2.24	2.59	2.89	3.60
	680. 754**	●	.125	1.19	1.69	2.07	7.70	2.39	2.93	3.38	3.78	4.40
	680. 814**	●	.156	1.61	2.28	2.79	10.4	3.23	3.95	4.56	5.10	6.25
	680. 874	●	.187	2.33	3.29	4.03	15.0	4.65	5.70	6.58	7.36	9.01
	680. 954	●	.218	3.52	4.98	6.10	22.7	7.04	8.62	9.96	11.13	13.64
80°	680. 345	●	.031	-	-	-	-	0.16	0.19	0.22	0.25	0.30
	680. 405***	●	.046	-	0.22	0.28	1.00	0.32	0.40	0.47	0.52	0.65
	680. 495	●	.062	0.26	0.37	0.46	1.70	0.53	0.65	0.75	0.83	1.02
	680. 575	●	.076	0.40	0.57	0.70	2.60	0.81	0.99	1.14	1.28	1.56
	680. 655	●	.093	0.65	0.92	1.13	4.20	1.30	1.60	1.84	2.06	2.52
	680. 715	●	.111	0.92	1.29	1.59	5.90	1.83	2.24	2.59	2.89	3.60
	680. 755	●	.125	1.19	1.69	2.07	7.70	2.39	2.93	3.38	3.78	4.40
	680. 815	●	.156	1.61	2.28	2.79	10.4	3.23	3.95	4.56	5.10	6.25
	680. 875	●	.187	2.33	3.29	4.03	15.0	4.65	5.70	6.58	7.36	9.01

¹ We reserve the right to supply material 316Ti or 316L under material no. 17.

Tungsten carbide available upon request

* 60° spray angle

** 70° spray angle

*** 75° spray angle

Conversion formula for this series: $\dot{V}_2 = \dot{V}_1 \cdot \sqrt{\frac{p_2}{p_1}}$

Ordering	Type	+	Material code	=	Ordering no.
example:	680. 873	+	17	=	680. 873. 17



Assembly accessories can be found in Chapter 12 "Accessories".

Disc type tips Series 690

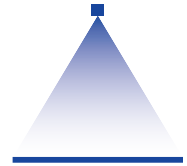

Features:

- Excellent for inexpensive headers with minimal clearance
- Orifices thread directly into pipe wall without any protrusion

Applications:

- Belt washing
- Web coating
- Spray washing of products on conveyors

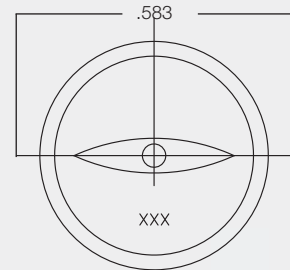

Series 690

Spray angle at 40 psi	Ordering number		Bore diameter (in.)	V̇ water [gal/min]								
	Material	316 SS 17 ¹		p [psi]								
				10 psi	20 psi	30 psi	liters per minute 2 bar	40 psi	60 psi	80 psi	100 psi	150 psi
0°	690.340	●	.031	-	-	-	-	0.16	0.19	0.22	0.25	0.30
	690.360	●	.040	-	-	0.21	0.80	0.25	0.29	0.34	0.38	0.46
	690.400	●	.046	-	0.22	0.27	1.00	0.31	0.38	0.44	0.49	0.60
	690.490	●	.032	0.26	0.37	0.46	1.70	0.53	0.65	0.75	0.83	1.02
	690.570	●	.076	0.40	0.57	0.70	2.60	0.81	0.99	1.14	1.28	1.56
690.650	●	.093	0.65	0.92	1.13	4.20	1.30	1.60	1.84	2.06	2.52	
35°	690.402	●	.046	-	0.22	0.27	1.00	0.31	0.38	0.44	0.49	0.60
	690.492	●	.062	0.26	0.37	0.46	1.70	0.53	0.65	0.75	0.83	1.02
	690.572	●	.076	0.40	0.57	0.70	2.60	0.81	0.99	1.14	1.28	1.56
	690.712	●	.111	0.92	1.29	1.59	5.90	1.83	2.24	2.59	2.89	3.54
	690.752	●	.125	1.19	1.69	2.07	7.70	2.39	2.93	3.38	3.78	4.63
690.872	●	.187	2.33	3.29	4.03	15.0	4.65	5.70	6.58	7.36	9.01	
50°	690.403	●	.046	-	0.22	0.27	1.00	0.31	0.38	0.44	0.49	0.60
	690.493	●	.062	0.26	0.37	0.46	1.70	0.53	0.65	0.75	0.83	1.02
	690.573	●	.076	0.40	0.57	0.70	2.60	0.81	0.99	1.14	1.28	1.56
	690.713	●	.111	0.92	1.29	1.59	5.90	1.83	2.24	2.59	2.89	3.54
	690.813	●	.156	1.19	1.69	2.07	7.70	2.39	2.93	3.38	3.78	4.63
	690.873	●	.187	2.33	3.29	4.03	15.0	4.65	5.70	6.58	7.36	9.01
	690.953	●	.218	3.52	4.98	6.10	22.7	7.04	8.62	9.96	11.13	13.64
690.993	●	.250	4.73	6.69	8.19	30.5	9.46	11.59	13.38	14.96	18.32	
65°	690.374**	●	.040	-	-	0.21	0.80	0.23	.28	0.32	0.36	0.44
	690.404	●	.046	-	0.22	0.27	1.00	0.31	0.38	0.44	0.49	0.60
	690.494	●	.062	0.26	0.37	0.46	1.70	0.53	0.65	0.75	0.83	1.02
	690.574*	●	.076	0.40	0.57	0.70	2.60	0.81	0.99	1.14	1.28	1.56
	690.714	●	.111	0.92	1.29	1.59	5.90	1.83	2.24	2.59	2.89	3.54
	690.754**	●	.125	1.19	1.69	2.07	7.70	2.39	2.93	3.38	3.78	4.63
	690.814**	●	.156	1.61	2.28	2.79	10.4	3.23	3.95	4.56	5.10	6.25
	690.874	●	.187	2.33	3.29	4.03	15.0	4.65	5.70	6.58	7.36	9.01
690.954	●	.218	3.52	4.98	6.10	22.7	7.04	8.62	9.96	11.13	13.64	
80°	690.345	●	.031	-	-	-	-	0.23	0.28	0.32	0.36	0.44
	690.405***	●	.046	-	0.22	0.27	1.00	0.31	0.38	0.44	0.49	0.60
	690.495	●	.062	0.26	0.37	0.46	1.70	0.53	0.65	0.75	0.83	1.02
	690.575	●	.076	0.40	0.57	0.70	2.60	0.81	0.99	1.14	1.28	1.56
	690.655	●	.093	0.65	0.92	1.13	4.20	1.30	1.60	1.84	2.06	2.52
	690.715	●	.111	0.92	1.29	1.59	5.90	1.83	2.24	2.59	2.89	3.54
	690.755	●	.125	1.19	1.69	2.07	7.70	2.39	2.93	3.38	3.78	4.63
	690.815	●	.156	1.61	2.28	2.79	10.4	3.23	3.95	4.56	5.10	6.25
	690.875	●	.187	2.33	3.29	4.03	15.0	4.65	5.70	6.58	7.36	9.01

¹ We reserve the right to supply material 316Ti or 316L under material no. 17.

Tungsten carbide available upon request

* 60° spray angle

** 70° spray angle

*** 75° spray angle



Assembly accessories can be found in Chapter 12 "Accessories".

Conversion formula for this series: $\dot{V}_2 = \dot{V}_1 \cdot \sqrt{\frac{p_2}{p_1}}$

Ordering example: Type 690.345 + Material code 17 = Ordering no. 690.345.17



Low pressure flat fan nozzles with ball joint

Series 676

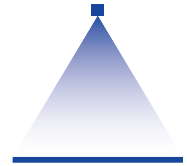

Features:

- Swivelling nozzle
- Precise spray alignment according to requirements
- Assembly with retaining nut, threaded socket, threaded nipple, welded nipple

Applications:

- Cleaning
- Cooling
- Lubrication



Series 676

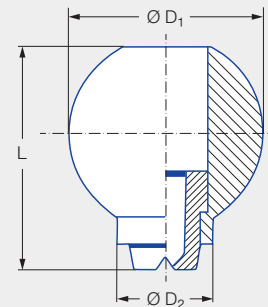

Dimensions [in]			Weight [lb] Brass	P _{max} [psi]
L	Ø D ₁	Ø D ₂		
0.98	0.87	0.43	0.10	435

Spray angle	Ordering number			Equivalent bore diameter A [in]	Narrowest free cross section Ø [in]	V̇ water [gal/min]							Spray width B [in] (at p = 75 psi)				
	Type	Material number				p [psi]										H = 10 [in]	H = 20 [in]
		16	30														
		Stainless steel 303	Brass			7	15	30	45	75	liters per minute 5 bar	145					
20°	676.301	●	●	0.03	0.02	0.04*	0.06*	0.09	0.11	0.14	0.51	0.19	3	6			
	676.361	●	●	0.04	0.03	0.08*	0.12*	0.17	0.21	0.27	1.00	0.37	3	6			
	676.441	●	●	0.05	0.04	0.16*	0.24	0.34	0.41	0.53	1.98	0.74	3	6			
	676.481	●	●	0.06	0.05	0.21*	0.30	0.43	0.53	0.68	2.53	0.95	3	6			
30°	676.302	●	●	0.03	0.02	0.04*	0.06*	0.09	0.11	0.14	0.51	0.19	5	9			
	676.362	●	●	0.04	0.03	0.08*	0.12*	0.17	0.21	0.27	1.00	0.37	5	9			
	676.402	●	●	0.05	0.047	0.13*	0.19	0.27	0.33	0.42	1.58	0.59	5	9			
	676.482	●	●	0.06	0.04	0.21*	0.30	0.43	0.53	0.68	2.53	0.95	5	9			
	676.562	●	●	0.08	0.06	0.32	0.47	0.67	0.82	1.06	3.95	1.48	5	9			
	676.642	●	●	0.10	0.07	0.52	0.76	1.08	1.32	1.70	6.33	2.36	6	10			
	676.722	●	●	0.12	0.09	0.82	1.20	1.69	2.07	2.68	9.96	3.72	6	10			
	676.762	●	●	0.14	0.11	1.04	1.52	2.15	2.63	3.40	12.65	4.73	6	10			
676.802	●	●	0.16	0.12	1.30	1.90	2.69	3.29	4.25	15.81	5.91	6	10				
45°	676.303	●	●	0.03	0.02	0.04*	0.06*	0.09	0.11	0.14	0.51	0.19	7	13			
	676.363	●	●	0.04	0.03	0.08*	0.12*	0.17	0.21	0.27	1.00	0.37	7	14			
	676.403	●	●	0.05	0.047	0.13*	0.19	0.27	0.33	0.42	1.58	0.59	8	15			
	676.483	●	●	0.06	0.04	0.21*	0.30	0.43	0.53	0.68	2.53	0.95	8	15			
	676.563	●	●	0.08	0.06	0.32	0.47	0.67	0.82	1.06	3.95	1.48	8	16			
	676.643	●	●	0.10	0.07	0.52	0.76	1.08	1.32	1.70	6.33	2.36	9	16			
	676.723	●	●	0.12	0.09	0.82	1.20	1.69	2.07	2.68	9.96	3.72	9	17			
	676.763	●	●	0.14	0.11	1.04	1.52	2.15	2.63	3.40	12.65	4.73	9	17			
676.803	●	●	0.16	0.12	1.30	1.90	2.69	3.29	4.25	15.81	5.91	9	17				
60°	676.304	●	●	0.03	0.016	0.04*	0.06*	0.09	0.11	0.14	0.51	0.19	10	19			
	676.334	●	●	0.04	0.02	0.06*	0.09*	0.12	0.15	0.19	0.71	0.27	10	19			
	676.364	●	●	0.05	0.024	0.08*	0.12*	0.17	0.21	0.27	1.00	0.37	10	20			
	676.404	●	●	0.06	0.03	0.13*	0.19	0.27	0.33	0.42	1.58	0.59	10	20			
	676.444	●	●	1.35	0.04	0.16*	0.24	0.34	0.41	0.53	1.98	0.74	10	20			
	676.484	●	●	1.50	0.04	0.21*	0.30	0.43	0.53	0.68	2.53	0.95	10	20			

* Differing spray pattern.

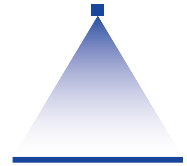

Spray angle	Ordering number			Equivalent bore diameter A [in]	Narrowest free cross section Ø [in]	V̇ water [gal/min]							Spray width B [in] (at p = 75 psi)		
	Type	Material number				p [psi]							liters per minute	H = 10 [in]	H = 20 [in]
		16	30			7	15	30	45	75	145				
		Stainless steel 303	Brass									5 bar			
60°	676.514	●	●	0.06	0.04	0.25*	0.35	0.50	0.61	0.79	3.00	1.12	11	20	
	676.564	●	●	0.08	0.05	0.33	0.47	0.66	0.81	1.04	3.95	1.48	11	21	
	676.604	●	●	0.09	0.06	0.41	0.59	0.83	1.02	1.32	4.98	1.86	11	21	
	676.644	●	●	0.10	0.065	0.53	0.75	1.06	1.29	1.67	6.33	2.36	11	21	
	676.674	●	●	0.11	0.07	0.63	0.89	1.25	1.54	1.98	7.51	2.81	11	22	
	676.724	●	●	0.12	0.08	0.83	1.18	1.66	2.04	2.63	9.96	3.72	11	22	
75°	676.764	●	●	0.14	0.09	1.06	1.50	2.11	2.59	3.34	12.65	4.73	11	22	
	676.145	●	●	0.008	0.005	–	0.01*	0.014	0.017	0.021	0.08	0.03	15	27	
	676.165	●	●	0.008	0.003	–	0.01*	0.017	0.02	0.03	0.10	0.04	15	27	
	676.185	●	●	0.008	0.006	–	0.014*	0.02	0.025	0.03	0.12	0.04	15	27	
	676.215	●	●	0.016	0.008	–	0.02*	0.03	0.04	0.05	0.18	0.07	15	27	
	676.245	●	●	0.02	0.012	–	0.03*	0.04	0.05	0.07	0.26	0.10	15	27	
90°	676.275	●	●	0.024	0.012	0.03*	0.04*	0.06	0.07	0.09	0.35	0.13	15	27	
	676.216	●	●	0.016	0.008	–	0.02*	0.03	0.04	0.05	0.18	0.07	17	31	
	676.276	●	●	0.024	0.012	0.03*	0.04*	0.06	0.07	0.09	0.35	0.13	17	31	
	676.306	●	●	0.03	0.016	0.04*	0.06*	0.08	0.11	0.14	0.51	0.19	17	31	
	676.336	●	●	0.035	0.02	0.06*	0.08*	0.12	0.15	0.19	0.71	0.27	17	32	
	676.366	●	●	0.04	0.02	0.08*	0.12*	0.17	0.21	0.27	1.00	0.37	18	33	
	676.406	●	●	0.047	0.028	0.13*	0.19	0.27	0.33	0.42	1.58	0.59	18	33	
	676.446	●	●	0.05	0.03	0.16*	0.24	0.33	0.40	0.52	1.98	0.74	18	34	
	676.486	●	●	0.06	0.03	0.21*	0.30	0.43	0.53	0.68	2.53	0.95	19	34	
	676.516	●	●	0.063	0.035	0.25*	0.36	0.51	0.62	0.81	3.00	1.12	19	35	
	676.566	●	●	0.08	0.04	0.32	0.47	0.67	0.82	1.06	3.95	1.48	19	35	
	676.606	●	●	0.09	0.047	0.41	0.60	0.85	1.04	1.34	4.98	1.86	20	36	
	676.646	●	●	0.10	0.05	0.52	0.76	1.08	1.32	1.70	6.33	2.36	20	37	
	676.676	●	●	0.11	0.06	0.62	0.90	1.28	1.56	2.02	7.51	2.81	20	37	
676.726	●	●	0.12	0.07	0.82	1.20	1.69	2.07	2.68	9.96	3.72	20	39		
120°	676.187	●	●	0.014	0.008	–	0.011*	0.02	0.03	0.035	0.13	0.05	20	42	
	676.217	●	●	0.016	0.008	–	0.02*	0.03	0.04	0.05	0.18	0.07	26	43	
	676.247	●	●	0.02	0.008	–	0.03*	0.04	0.05	0.07	0.26	0.10	26	43	
	676.277	●	●	0.024	0.012	–	0.04*	0.06	0.07	0.09	0.35	0.13	26	45	
	676.307	●	●	0.03	0.012	0.04*	0.06*	0.08	0.11	0.14	0.51	0.19	28	49	
	676.337	●	●	0.035	0.016	0.06*	0.08*	0.12	0.15	0.19	0.71	0.27	29	53	
	676.367	●	●	0.04	0.02	0.08*	0.12*	0.17	0.21	0.27	1.00	0.37	18	56	
	676.407	●	●	0.047	0.024	0.13*	0.19	0.27	0.33	0.42	1.58	0.59	18	58	
	676.447	●	●	0.05	0.03	0.16*	0.24	0.33	0.40	0.52	1.98	0.74	18	60	
	676.487	●	●	0.06	0.024	0.21*	0.30	0.43	0.53	0.68	2.53	0.95	19	61	
	676.517	●	●	0.063	0.035	0.25*	0.36	0.51	0.62	0.81	3.00	1.12	19	61	
	676.567	●	●	0.08	0.035	0.32	0.47	0.67	0.82	1.06	3.95	1.48	19	63	
	676.607	●	●	0.09	0.04	0.41	0.60	0.85	1.04	1.34	4.98	1.86	20	64	
	676.647	●	●	0.10	0.05	0.52	0.76	1.08	1.32	1.70	6.33	2.36	20	65	
	676.677	●	●	0.11	0.055	0.62	0.90	1.28	1.56	2.02	7.51	2.81	20	65	
	676.727	●	●	0.12	0.06	0.82	1.20	1.69	2.07	2.68	9.96	3.72	20	66	
676.767	●	●	0.14	0.07	1.04	1.52	2.15	2.63	3.40	12.65	4.73	4.7	67		

* Differing spray pattern.

Conversion formula for this series: $\dot{V}_2 = \dot{V}_1 \cdot \sqrt{\frac{p_2}{p_1}}$

Ordering Type + Material no. = Ordering no.
example: 676.514 + 16 = 676.514.16



Assembly accessories can be found in Chapter 12 "Accessories".

Low pressure flat fan nozzles with dovetail guide

Series 660

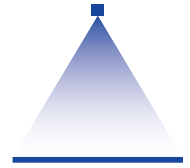

Features:

- Uniform, parabolic liquid distribution
- Stable spray angle
- Spray automatically aligned approx. 5° to the longitudinal axis of the pipe due to dovetail guide
- Assembly with retaining nut
- Non-clogging
- High spray energy

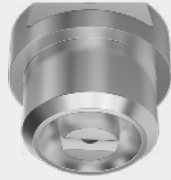

Series 660

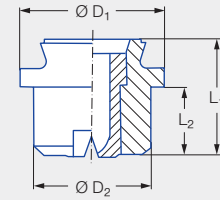

Applications:

- Cleaning installations
- Spray pipes
- Cooling pipes

Connection	Dimensions [in]				Weight [lb] Brass
	L ₁	L ₂	Ø D ₁	Ø D ₂	
Assembly with retaining nut 3/8 BSPP and dovetail guide	0.47	0.28	0.58	0.47	0.02

Spray angle	Ordering number				Equivalent bore diameter A [in]	Narrowest free cross section Ø [in]	V̇ water [gal/min]							Spray width B [in] (at p = 75 psi)	
	Type	Material number					p [psi]								
		16	17 ¹	30											
		Stainless steel 303	Stainless steel 316Ti / Stainless steel 316L	Brass			7	15	30	45	75	liters per minute 5 bar	145	H = 10 [in]	H = 20 [in]
20°	660.301	●	●	●	0.03	0.02	0.04*	0.06*	0.09	0.11	0.14	0.51	0.19	3	6
	660.361	●	●	●	0.04	0.03	0.08*	0.12*	0.17	0.21	0.27	1.00	0.37	3	6
	660.441	●	●	●	0.05	0.04	0.16*	0.24	0.34	0.41	0.53	1.98	0.74	3	6
	660.481	●	●	●	0.06	0.05	0.21*	0.30	0.43	0.53	0.68	2.53	0.95	3	6
30°	660.302	●	●	●	0.02	0.02	0.04*	0.06*	0.09	0.11	0.14	0.51	0.19	5	9
	660.362	●	●	●	0.04	0.03	0.08*	0.12*	0.17	0.21	0.27	1.00	0.37	5	9
	660.402	●	●	●	0.05	0.035	0.13*	0.13	0.27	0.33	0.42	1.58	0.59	5	9
	660.482	●	●	●	0.06	0.04	0.21*	0.30	0.43	0.53	0.68	2.53	0.95	5	9
	660.562	●	●	●	0.08	0.06	0.32	0.32	0.67	0.81	1.04	3.95	1.48	5	9
45°	660.303	●	●	●	0.03	0.02	0.04*	0.06*	0.09	0.11	0.14	0.51	0.19	7	13
	660.363	●	●	●	0.04	0.024	0.08*	0.12*	0.17	0.21	0.27	1.00	0.37	7	14
	660.403	●	●	●	0.05	0.035	0.13*	0.13	0.27	0.33	0.42	1.58	0.59	8	15
	660.483	●	●	●	0.06	0.04	0.21*	0.30	0.43	0.53	0.68	2.53	0.95	8	15
	660.563	●	●	●	0.08	0.06	0.32	0.32	0.67	0.81	1.04	3.95	1.48	8	16
	660.643	●	●	●	0.10	0.07	0.52	0.76	1.08	1.32	1.70	6.33	2.36	9	16
60°	660.304	●	●	●	0.03	0.016	0.04*	0.06*	0.09	0.11	0.14	0.51	0.19	10	19
	660.334	●	●	●	0.035	0.02	0.06*	0.09*	0.12	0.15	0.19	0.71	0.27	10	19
	660.364	●	●	●	0.04	0.024	0.08*	0.12*	0.17	0.21	0.27	1.00	0.37	10	20
	660.404	●	●	●	0.047	0.03	0.13*	0.19	0.27	0.33	0.42	1.58	0.59	10	20
	660.444	●	●	●	0.05	0.04	0.16*	0.24	0.34	0.41	0.53	1.98	0.74	10	20

* Differing spray pattern.

¹ We reserve the right to supply material 316Ti or 316L under material no. 17.





Spray angle	Ordering number				Equivalent bore diameter A [in]	Narrowest free cross section Ø [in]	V̇ water [gal/min]						Spray width B [in] (at p = 75 psi)		
	Type	Material number					p [psi]						H = 10 [in]	H = 20 [in]	
		16	17 ¹	30			7	15	30	45	75	liters per minute 5 bar			145
		Stainless steel 303	Stainless steel 316Ti/ Stainless steel 316L	Brass											
60°	660.484	●	●	●	0.06	0.04	0.21*	0.30	0.43	0.53	0.68	2.53	0.95	10	20
	660.514	●	●	●	0.063	0.043	0.25*	0.36	0.51	0.62	0.81	3.00	1.12	11	20
	660.564	●	●	●	0.08	0.05	0.32	0.47	0.67	0.82	1.06	3.95	1.48	11	21
	660.604	●	●	●	0.09	0.06	0.41	0.60	0.85	1.04	1.34	4.98	1.86	11	21
	660.644	●	●	●	0.10	0.063	0.52	0.76	1.08	1.32	1.70	6.33	2.36	11	21
	660.724	●	●	●	0.12	0.08	0.82	1.20	1.69	2.07	2.68	9.96	3.72	11	22
	660.804	●	●	●	0.16	0.10	1.30	1.90	2.69	3.29	4.25	15.81	5.91	11	23
75°	660.145	●		●	0.008	0.005	–	0.01*	0.014	0.017	0.021	0.08	0.03	15	27
	660.165	●		●	0.008	0.005	–	0.01*	0.017	0.02	0.03	0.10	0.04	15	27
	660.185	●		●	0.008	0.006	–	0.011*	0.02	0.03	0.035	0.13	0.05	15	27
	660.215	●		●	0.02	0.008	–	0.02*	0.03	0.04	0.05	0.18	0.07	15	27
	660.245	●		●	0.02	0.012	–	0.03*	0.04	0.05	0.07	0.26	0.10	15	27
	660.275	●		●	0.024	0.012	0.03*	0.04*	0.06	0.07	0.09	0.35	0.13	15	27
90°	660.216	●		●	0.016	0.008	–	0.02*	0.03	0.04	0.05	0.18	0.07	17	31
	660.276	●		●	0.02	0.012	0.03*	0.04*	0.06	0.07	0.09	0.35	0.13	17	31
	660.306	●	●	●	0.03	0.016	0.04*	0.06*	0.09	0.11	0.14	0.51	0.19	17	31
	660.336	●	●	●	0.035	0.02	0.06*	0.09*	0.12	0.15	0.19	0.71	0.27	17	32
	660.366	●	●	●	0.04	0.02	0.08*	0.12*	0.17	0.21	0.27	1.00	0.37	18	33
	660.406	●	●	●	0.047	0.028	0.13*	0.19	0.27	0.33	0.42	1.58	0.59	18	33
	660.446	●	●	●	0.05	0.03	0.16*	0.24	0.34	0.41	0.53	1.98	0.74	18	34
	660.486	●	●	●	0.06	0.03	0.21*	0.30	0.43	0.53	0.68	2.53	0.95	19	34
	660.516	●	●	●	0.063	0.035	0.25*	0.36	0.51	0.62	0.81	3.00	1.12	19	35
	660.566	●	●	●	0.08	0.04	0.32	0.47	0.67	0.82	1.06	3.95	1.48	19	35
	660.606	●	●	●	0.09	0.047	0.41	0.60	0.85	1.04	1.34	4.98	1.86	20	36
	660.646	●	●	●	0.10	0.05	0.52	0.76	1.08	1.32	1.70	6.33	2.36	20	37
	660.676	●	●	●	0.11	0.06	0.62	0.90	1.28	1.56	2.02	7.51	2.81	20	37
	660.726	●	●	●	0.12	0.07	0.82	1.20	1.69	2.07	2.68	9.96	3.72	20	39
	660.806		●	●	0.16	0.09	1.30	1.90	2.69	3.29	4.25	15.81	5.91	21	41
120°	660.187	●		●	0.014	0.008	–	0.011*	0.02	0.03	0.035	0.13	0.05	25	42
	660.217	●		●	0.016	0.008	–	0.02*	0.03	0.04	0.05	0.18	0.07	26	43
	660.247	●		●	0.02	0.012	–	0.03*	0.04	0.05	0.07	0.26	0.10	26	43
	660.277	●		●	0.024	0.012	0.03*	0.04*	0.06	0.07	0.09	0.35	0.13	26	45
	660.307	●		●	0.03	0.012	0.04*	0.06*	0.09	0.11	0.14	0.51	0.19	28	49
	660.337	●	●	●	0.035	0.016	0.06*	0.09*	0.12	0.15	0.19	0.71	0.27	29	53
	660.367	●	●	●	0.04	0.016	0.08*	0.12*	0.17	0.21	0.27	1.00	0.37	31	56
	660.407	●	●	●	0.047	0.02	0.13*	0.19	0.27	0.33	0.42	1.58	0.59	33	58
	660.447	●	●	●	0.05	0.02	0.16*	0.24	0.34	0.41	0.53	1.98	0.74	33	60
	660.487	●	●	●	0.06	0.02	0.21*	0.30	0.43	0.53	0.68	2.53	0.95	33	61
	660.517	●	●	●	0.063	0.035	0.25*	0.36	0.51	0.62	0.81	3.00	1.12	33	61
	660.567	●	●	●	0.08	0.035	0.32	0.47	0.67	0.82	1.06	3.95	1.48	34	63
	660.607	●	●	●	0.09	0.04	0.41	0.60	0.85	1.04	1.34	4.98	1.86	34	64
	660.647	●	●	●	0.10	0.05	0.52	0.76	1.08	1.32	1.70	6.33	2.36	35	65
	660.727	●	●	●	0.12	0.06	0.83	1.20	1.66	2.04	2.63	9.96	3.72	35	66
		660.807	●		●	0.16	0.08	1.30	1.90	2.69	3.29	4.25	15.81	5.91	35

* Differing spray pattern.

¹ We reserve the right to supply material 316Ti or 316L under material no. 17.

Conversion formula for this series: $\dot{V}_2 = \dot{V}_1 \cdot \sqrt{\frac{p_2}{p_1}}$

Ordering Type + Material no. = Ordering no.
example: 660.484 + 16 = 660.484.16



Assembly accessories can be found in Chapter 12 "Accessories".

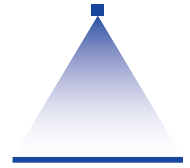

Accessories

Nipple **066. 011. 17** (316 SS) Weight: .14 lb.

Retaining nut **065. 200. 16** (303 SS)
065. 200. 17 (316 SS)
065. 200. 30 (Brass) Weight: .13 lb.

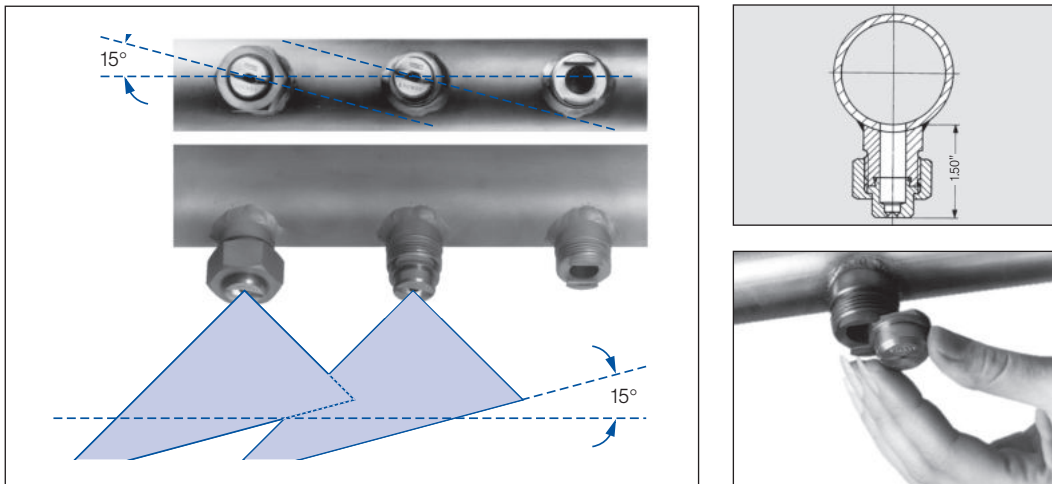

Standard accessories, alignment, and installation for the Series 664 dovetail nozzle tip

A listing of alternatives for various assembly possibilities is shown in the Accessories section beginning on page 127.

Low pressure flat fan nozzles with dovetail guide

Series 664/665

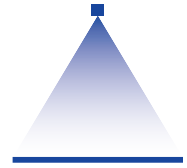

Features:

- Uniform, parabolic liquid distribution
- Stable spray angle
- Spray automatically aligned approx. 15° to the longitudinal axis of the pipe via dovetail guide
- Assembly with retaining nut
- Non-clogging
- High spray energy

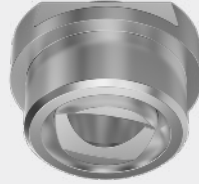

Series 664/665

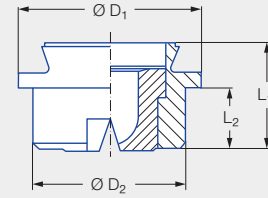

Applications:

- Cleaning installations
- Spray pipes
- Roll cooling
- Cooling pipes
- Cooling of rolled stock

Code	Dimensions [in]				Weight [lb]
	L ₁	L ₂	Ø D ₁	Ø D ₂	
Assembly with retaining nut 3/4 BSPP and dovetail guide	0.55	0.31	0.94	0.79	.08

Spray angle	Ordering number				Equivalent bore diameter A [in]	Narrowest free cross section Ø [in]	V̇ water [gal/min]							Spray width B [in] (at p = 75 psi)	
	Type	Material number					p [psi]								
		16	17 ¹	30			7	15	30	45	75	liters per minute 5 bar	145		
20°	664.721	●	●	●	0.12	0.10	0.82	1.20	1.69	2.07	2.68	9.96	3.72	4	7
	664.801	●	●	●	0.16	0.13	1.30	1.90	2.69	3.29	4.25	15.81	5.91	4	7
	664.881	●	●	●	0.20	0.16	2.08	3.04	4.30	5.26	6.80	25.30	9.45	4	7
	664.921	●	●	●	0.22	0.17	2.60	3.80	5.37	6.58	8.49	31.62	11.81	4	7
	664.961	●	●	●	0.24	0.20	3.24	4.75	6.72	8.23	10.62	39.53	14.77	4	7
30°	664.722	●	●	●	0.12	0.09	0.82	1.20	1.69	2.07	2.68	9.96	3.72	6	10
	664.762	●	●	●	0.14	0.11	1.04	1.52	2.15	2.63	3.40	12.65	4.73	6	10
	664.802	●	●	●	0.16	0.12	1.30	1.90	2.69	3.29	4.25	15.81	5.91	6	10
	664.882	●	●	●	0.20	0.16	2.08	3.04	4.30	5.26	6.80	25.30	9.45	6	11
	664.922	●	●	●	0.22	0.17	2.60	3.80	5.37	6.58	8.49	31.62	11.81	6	11
	664.962	●	●	●	0.24	0.20	3.24	4.75	6.72	8.23	10.62	39.53	14.77	6	11
	665.042	●	●	●	0.31	0.25	5.19	7.60	10.75	13.16	16.99	63.25	23.63	6	11
	665.122	●	●	●	0.39	0.32	8.18	11.97	16.92	20.73	26.76	99.61	37.21	6	11

¹ We reserve the right to supply material 316Ti or 316L under material no. 17.



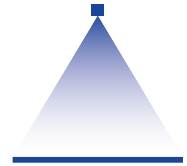

Spray angle	Ordering number				Equivalent bore diameter A [in]	Narrowest free cross section Ø [in]	V̇ water [gal/min]							Spray width B [in] (at p = 75 psi)	
	Type	Material number					p [psi]								
		16	17 ¹	30								liters per minute	H = 10 [in]		
		Stainless steel 303	Stainless steel 316Ti/ Stainless steel 316L	Brass			7	15	30	45	75	5 bar	145		
45°	664.723	●	●	●	0.12	0.09	0.82	1.20	1.69	2.07	2.68	9.96	3.72	9	17
	664.763	●	●	●	0.14	0.10	1.04	1.52	2.15	2.63	3.40	12.65	4.73	9	17
	664.803	●	●	●	0.16	0.12	1.32	1.90	2.69	3.29	4.25	15.81	5.91	9	17
	664.843	●	●	●	0.18	0.13	1.62	2.37	3.36	4.11	5.31	19.76	7.38	9	17
	664.883	●	●	●	0.20	0.15	2.08	3.04	4.30	5.26	6.80	25.30	9.45	9	17
	664.923	●	●	●	0.22	0.165	2.60	3.80	5.37	6.58	8.49	31.62	11.81	9	17
	664.963	●	●	●	0.24	0.17	3.24	4.75	6.72	8.23	10.62	39.53	14.77	9	17
	665.043			●	0.31	0.23	5.19	7.60	10.75	13.16	16.99	63.25	23.63	9	17
60°	664.724	●	●	●	0.12	0.08	0.82	1.20	1.69	2.07	2.68	9.96	3.72	11	22
	664.764	●	●	●	0.14	0.09	1.04	1.52	2.15	2.63	3.40	12.65	4.73	11	22
	664.804	●	●	●	0.16	0.10	1.32	1.90	2.69	3.29	4.25	15.81	5.91	11	23
	664.844	●	●	●	0.18	0.12	1.62	2.37	3.36	4.11	5.31	19.76	7.38	11	23
	664.884	●	●	●	0.20	0.13	2.08	3.04	4.30	5.26	6.80	25.30	9.45	11	23
	664.924	●	●	●	0.22	0.16	2.60	3.80	5.37	6.58	8.49	31.62	11.81	11	23
	664.964	●	●	●	0.24	0.17	3.24	4.75	6.72	8.23	10.62	39.53	14.77	11	23
	665.044	●	●	●	0.31	0.22	5.19	7.60	10.75	13.16	16.99	63.25	23.63	11	23
	665.084		●	●	0.35	0.24	6.49	9.50	13.43	16.45	21.24	79.06	29.24	11	23
665.124			●	0.39	0.29	8.18	11.97	16.92	20.73	26.76	99.61	37.21	11	23	
90°	664.726	●	●	●	0.12	0.067	0.82	1.20	1.69	2.07	2.68	9.96	3.72	20	39
	664.766	●	●	●	0.14	0.075	1.04	1.52	2.15	2.63	3.40	12.65	4.73	21	39
	664.806	●	●	●	0.16	0.09	1.32	1.90	2.69	3.29	4.25	15.81	5.91	21	41
	664.846	●	●	●	0.18	0.09	1.62	2.37	3.36	4.11	5.31	19.76	7.38	21	41
	664.886	●	●	●	0.20	0.12	2.08	3.04	4.30	5.26	6.80	25.30	9.45	21	42
	664.926	●	●	●	0.22	0.14	2.60	3.80	5.37	6.58	8.49	31.62	11.81	21	42
	664.966	●	●	●	0.24	0.15	3.24	4.75	6.72	8.23	10.62	39.53	14.77	21	42
	665.046			●	0.31	0.19	5.19	7.60	10.75	13.16	16.99	63.25	23.63	21	42
	665.126			●	0.39	0.25	8.18	11.97	16.92	20.73	26.76	99.61	37.21	21	42
120°	664.727	●	●	●	0.12	0.06	0.82	1.20	1.69	2.07	2.68	9.96	3.72	35	66
	664.767	●	●	●	0.14	0.07	1.04	1.52	2.15	2.63	3.40	12.65	4.73	35	67
	664.807	●	●	●	0.16	0.08	1.32	1.90	2.69	3.29	4.25	15.81	5.91	35	67
	664.887	●	●	●	0.20	0.10	2.08	3.04	4.30	5.26	6.80	25.30	9.45	36	67
	664.927	●	●	●	0.22	0.11	2.60	3.80	5.37	6.58	8.49	31.62	11.81	36	67
	664.967			●	0.24	0.13	3.24	4.75	6.72	8.23	10.62	39.53	14.77	36	67
	665.047			●	0.31	0.17	5.19	7.60	10.75	13.16	16.99	63.25	23.63	36	67

¹ We reserve the right to supply material 316Ti or 316L under material no. 17.

Conversion formula for this series: $\dot{V}_2 = \dot{V}_1 \cdot \sqrt{\frac{p_2}{p_1}}$

Ordering Type + Material no. = Ordering no.
example: 664.723 + 16 = 664.723.16



Assembly accessories can be found in Chapter 12 "Accessories".

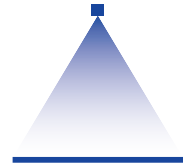

Accessories

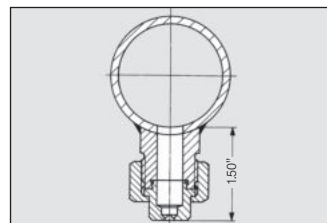
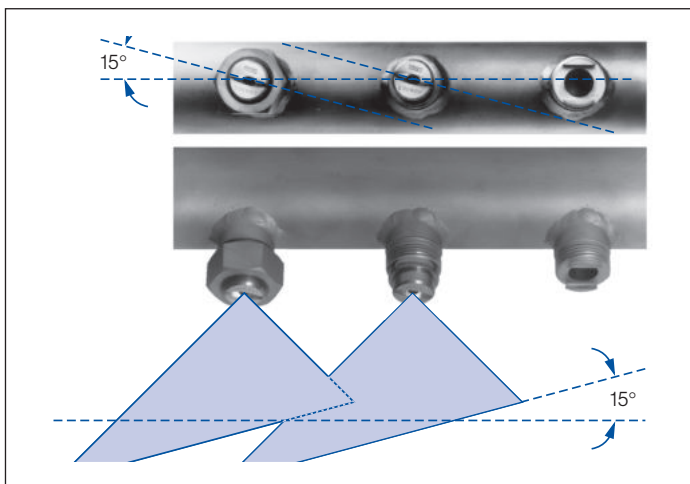
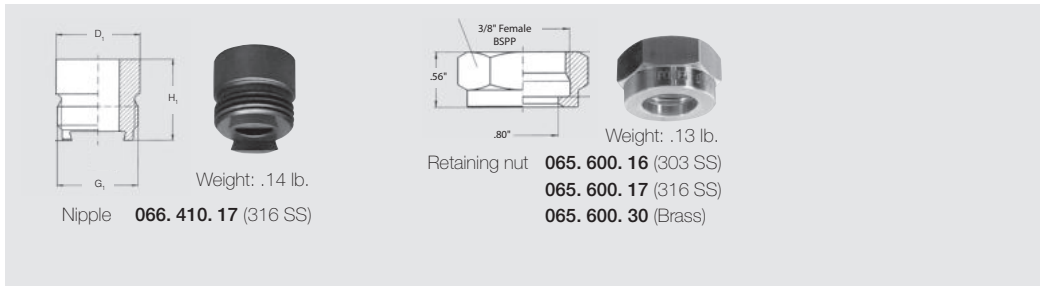

Standard accessories, alignment, and installation for the Series 664 dovetail nozzle tip

A listing of alternatives for various assembly possibilities is shown in the Accessories section beginning on page 127.

High pressure flat fan nozzles

Series 602

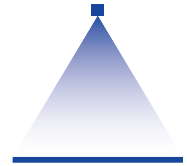

Features:

- Sharp, uniform flat fan spray
- Extremely narrow spray depth
- Housing: Stainless steel 303,
Insert: Hardened stainless steel 420F

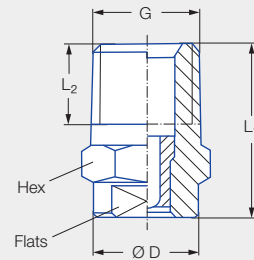

Applications:

- High pressure cleaning

Series 602

G	Dimensions [in]					Weight [lb]	p _{max} ¹ [psi]
	L ₁	L ₂	Ø D	Hex (mm)	Flats (mm)		
1/4 BSPT	0.87	0.39	0.51	14	10	.04	approx. 10,153
1/4 NPT	0.87	0.40	0.51	14	10	.04	approx. 10,153

¹ Applies only to operation at constant pressure.

International Code US gal/min. at 40 psi	Ordering number							Equivalent bore diameter A [in]	V̇ water [gal/min]								
	Series	Flow rate code				Mat. No. A3	Connection		p [psi]								
		Spray angle					Stainless steel 303/420F		1/4 BSPT	1/4 NPT							
		20°	30°	45°	60°						40	600	liters per minute 80 bar	1000	1500	2000	3000
02	602	361	362	363	364	●	00	07	0.039	0.20	0.77	4.08	1.00	1.22	1.41	1.73	2.12
021	602	371	372	373	374	●	00	07	0.040	0.21	0.81	4.28	1.05	1.29	1.49	1.82	2.23
025	602	381	382	383	384	●	00	07	0.043	0.25	0.97	5.10	1.25	1.53	1.77	2.16	2.65
028	602	391	392	393	394	●	00	07	0.045	0.28	1.09	5.71	1.40	1.72	1.98	2.43	2.97
03	602	401	402	403	404	●	00	07	0.046	0.30	1.16	6.11	1.50	1.84	2.12	2.60	3.18
034	602	411	412	413	414	●	00	07	0.051	0.34	1.32	6.93	1.70	2.08	2.40	2.94	3.61
038	602	441	442	443		●	00	07	0.052	0.38	1.47	7.75	1.90	2.33	2.69	3.29	4.03
04	602	451	452	453	454	●	00	07	0.053	0.40	1.55	8.16	2.00	2.45	2.83	3.47	4.25
043	602	461	462			●	00	07	0.054	0.43	1.67	8.77	2.15	2.63	3.04	3.72	4.56
045	602	471	472	473	474	●	00	07	0.055	0.45	1.74	9.18	2.25	2.76	3.18	3.90	4.77
05	602	481	482	483	484	●	00	07	0.061	0.50	1.94	10.20	2.50	3.06	3.54	4.33	5.30
055	602	501	502	503	504	●	00	07	0.063	0.55	2.13	11.22	2.75	3.37	3.89	4.76	5.83
06	602	521	522	523	524	●	00	07	0.068	0.60	2.32	12.24	3.00	3.67	4.24	5.20	6.36
065	602	531	532	533	534	●	00	07	0.069	0.65	2.52	13.26	3.25	3.98	4.60	5.63	6.89
07	602	541	542	543	544	●	00	07	0.071	0.70	2.71	14.28	3.50	4.29	4.95	6.06	7.42
075	602	551	552	553	554	●	00	07	0.075	0.75	2.90	15.29	3.75	4.59	5.30	6.49	7.95
08	602	571	572	573	574	●	00	07	0.080	0.80	3.10	16.31	4.00	4.90	5.66	6.93	8.49
087	602	581	582	583	584	●	00	07	0.081	0.87	3.37	17.74	4.35	5.33	6.15	7.53	9.23
09	602	591	592	593	594	●	00	07	0.083	0.90	3.49	18.35	4.50	5.51	6.37	7.80	9.55
10	602	601	602	603	604	●	00	07	0.091	1.00	3.87	20.38	5.00	6.12	7.07	8.66	10.60
11	602	621	622	623	624	●	00	07	0.094	1.10	4.26	22.42	5.50	6.74	7.78	9.53	11.67
125	602	641	642	643	644	●	00	07	0.098	1.25	4.84	25.48	6.25	7.65	8.84	10.83	13.26
131	602	651	652	653	654	●	00	07	0.100	1.31	5.07	26.71	6.55	8.02	9.27	11.35	13.90
139	602	661	662	663	664	●	00	07	0.104	1.39	5.38	28.34	6.95	8.51	9.83	12.04	14.74
15	602	671	672	673	674	●	00	07	0.106	1.50	5.81	30.58	7.50	9.18	10.60	12.99	15.91
175	602	701	702	703	704	●	00	07	0.118	1.75	6.78	35.68	8.75	10.72	12.38	15.16	18.56
20	602			723	724	●	00	07	0.120	2.00	7.75	40.78	10.00	12.25	14.14	17.32	21.21
25	602			763	764	●	00	07	0.138	2.50	9.68	50.97	12.50	15.31	17.68	21.65	26.52
30	602			793		●	00	07	0.153	3.00	11.62	61.16	15.00	18.37	21.21	25.98	31.82

Conversion formula for this series: $\dot{V}_2 = \dot{V}_1 \cdot \sqrt{\frac{P_2}{P_1}}$



Assembly accessories can be found in Chapter 12 "Accessories".

Ordering example: 602 + 361 + A3 + 00 = Ordering no. = 602.361.A3.00

High pressure flat fan nozzles

Series 608

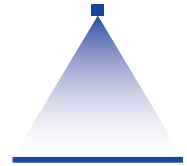

Features:

- Sharp, uniform flat fan spray
- Extremely narrow spray depth
- Housing: Stainless steel 303,
Insert: Hardened stainless steel 420F

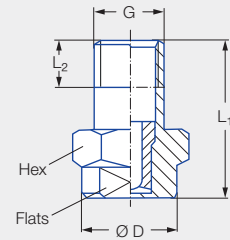

Applications:

- High pressure cleaning

Series 608

G	Dimensions [in]					Weight [lb]	P _{max} ¹ [bar]
	L ₁	L ₂	Ø D	Hex (mm)	Flats (mm)		
1/8 BSPT	0.87	0.39	0.51	14	10	.04	approx. 10,153
1/8 NPT	0.87	0.40	0.51	14	10	.04	approx. 10,153

¹ Applies only to operation at constant pressure.

International Code US gal/min. at 40 psi	Ordering number								Equivalent bore diameter A [in]	V̇ water [gal/min]								
	Series	Flow rate code				Mat. No. A3	Connection			p [psi]								
		Spray angle					Stainless steel 303/420F	1/8 BSPT		1/8 NPT	40	600	liters per minute 80 bar	1000	1500	2000	3000	4500
		20°	30°	45°	60°													
02	608	361	362	363	364	●	00	07	0.039	0.20	0.77	4.08	1.00	1.22	1.41	1.73	2.12	
021	608	371	372	373	374	●	00	07	0.040	0.21	0.81	4.28	1.05	1.29	1.49	1.82	2.23	
025	608	381	382	383	384	●	00	07	0.043	0.25	0.97	5.10	1.25	1.53	1.77	2.16	2.65	
028	608	391	392	393	394	●	00	07	0.045	0.28	1.09	5.71	1.40	1.72	1.98	2.43	2.97	
03	608	401	402	403	404	●	00	07	0.046	0.30	1.16	6.11	1.50	1.84	2.12	2.60	3.18	
034	608	411	412	413	414	●	00	07	0.051	0.34	1.32	6.93	1.70	2.08	2.40	2.94	3.61	
038	608	441	442	443		●	00	07	0.052	0.38	1.47	7.75	1.90	2.33	2.69	3.29	4.03	
04	608	451	452	453	454	●	00	07	0.053	0.40	1.55	8.16	2.00	2.45	2.83	3.47	4.25	
043	608	461	462			●	00	07	0.054	0.43	1.67	8.77	2.15	2.63	3.04	3.72	4.56	
045	608	471	472	473	474	●	00	07	0.055	0.45	1.74	9.18	2.25	2.76	3.18	3.90	4.77	
05	608	481	482	483	484	●	00	07	0.061	0.50	1.94	10.20	2.50	3.06	3.54	4.33	5.30	
055	608	501	502	503	504	●	00	07	0.063	0.55	2.13	11.22	2.75	3.37	3.89	4.76	5.83	
06	608	521	522	523	524	●	00	07	0.068	0.60	2.32	12.24	3.00	3.67	4.24	5.20	6.36	
065	608	531	532	533	534	●	00	07	0.069	0.65	2.52	13.26	3.25	3.98	4.60	5.63	6.89	
07	608	541	542	543	544	●	00	07	0.071	0.70	2.71	14.28	3.50	4.29	4.95	6.06	7.42	
075	608	551	552	553	554	●	00	07	0.075	0.75	2.90	15.29	3.75	4.59	5.30	6.49	7.95	
08	608	571	572	573	574	●	00	07	0.080	0.80	3.10	16.31	4.00	4.90	5.66	6.93	8.49	
087	608	581	582	583	584	●	00	07	0.081	0.87	3.37	17.74	4.35	5.33	6.15	7.53	9.23	
09	608	591	592	593	594	●	00	07	0.083	0.90	3.49	18.35	4.50	5.51	6.37	7.80	9.55	
10	608	601	602	603	604	●	00	07	0.091	1.00	3.87	20.38	5.00	6.12	7.07	8.66	10.60	

Conversion formula for this series: $\dot{V}_2 = \dot{V}_1 \cdot \sqrt{\frac{p_2}{p_1}}$



Assembly accessories can be found in Chapter 12 "Accessories".

Ordering Series + Flow rate code + Material no. + Code = Ordering no.
example: 608 + 361 + A3 + 00 = 608.361.A3.00

High pressure flat fan nozzles

Series 652

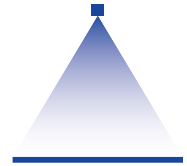

Features:

- Sharp, uniform flat fan spray
- Extremely narrow spray depth
- Assembly with retaining nut
- Housing: Stainless steel 303,
Insert: Hardened stainless steel 420F

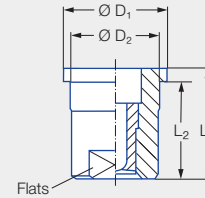

Applications:

- High pressure cleaning

Series 652

G	Dimensions [in]					Weight [lb]	p _{max} ¹ [psi]
	L ₁	L ₂	Ø D ₁	Ø D ₂	Flats (mm)		
Assembly with retaining nut 3/8 BSPP	0.63	0.55	0.58	0.50	10	0.03	approx. 4,351

¹ Applies only to operation at constant pressure.

International Code US gal/min. at 40 psi	Ordering number							Equivalent bore diameter A [in]	V̇ water [gal/min]								
	Series	Flow rate code				Mat. No. A3 Stainless steel 303/420F	Connection For retaining nut		p [psi]								
		Spray angle							liters per minute	40	600	80 bar	1000	1500	2000	3000	4500
		20°	30°	45°	60°												
02	652	361	362	363	364	●	29	0.039	0.20	0.77	4.08	1.00	1.22	1.41	1.73	2.12	
021	652	371	372	373	374	●	29	0.040	0.21	0.81	4.28	1.05	1.29	1.49	1.82	2.23	
025	652	381	382	383	384	●	29	0.043	0.25	0.97	5.10	1.25	1.53	1.77	2.16	2.65	
028	652	391	392	393	394	●	29	0.045	0.28	1.09	5.71	1.40	1.72	1.98	2.43	2.97	
03	652	401	402	403	404	●	29	0.046	0.30	1.16	6.11	1.50	1.84	2.12	2.60	3.18	
034	652	411	412	413	414	●	29	0.051	0.34	1.32	6.93	1.70	2.08	2.40	2.94	3.61	
038	652	441	442	443	444	●	29	0.052	0.38	1.47	7.75	1.90	2.33	2.69	3.29	4.03	
04	652	451	452	453	454	●	29	0.053	0.40	1.55	8.16	2.00	2.45	2.83	3.47	4.25	
043	652	461	462	463	464	●	29	0.054	0.43	1.67	8.77	2.15	2.63	3.04	3.72	4.56	
045	652	471	472	473	474	●	29	0.055	0.45	1.74	9.18	2.25	2.76	3.18	3.90	4.77	
05	652	481	482	483	484	●	29	0.061	0.50	1.94	10.20	2.50	3.06	3.54	4.33	5.30	
055	652	501	502	503	504	●	29	0.063	0.55	2.13	11.22	2.75	3.37	3.89	4.76	5.83	
06	652	521	522	523	524	●	29	0.068	0.60	2.32	12.24	3.00	3.67	4.24	5.20	6.36	
065	652	531	532	533	534	●	29	0.069	0.65	2.52	13.26	3.25	3.98	4.60	5.63	6.89	
07	652	541	542	543	544	●	29	0.071	0.70	2.71	14.28	3.50	4.29	4.95	6.06	7.42	
075	652	551	552	553	554	●	29	0.075	0.75	2.90	15.29	3.75	4.59	5.30	6.49	7.95	
08	652	571	572	573	574	●	29	0.080	0.80	3.10	16.31	4.00	4.90	5.66	6.93	8.49	
087	652	581	582	583	584	●	29	0.081	0.87	3.37	17.74	4.35	5.33	6.15	7.53	9.23	
09	652	591	592	593	594	●	29	0.083	0.90	3.49	18.35	4.50	5.51	6.37	7.80	9.55	
10	652	601	602	603	604	●	29	0.091	1.00	3.87	20.38	5.00	6.12	7.07	8.66	10.60	
11	652	621	622	623	624	●	29	0.094	1.10	4.26	22.42	5.50	6.74	7.78	9.53	11.67	
125	652	641	642	643	644	●	29	0.098	1.25	4.84	25.48	6.25	7.65	8.84	10.83	13.26	
131	652	651	652	653	654	●	29	0.100	1.31	5.07	26.71	6.55	8.02	9.27	11.35	13.90	
139	652	661	662	663	664	●	29	0.104	1.39	5.38	28.34	6.95	8.51	9.83	12.04	14.74	
15	652	671	672	673	674	●	29	0.106	1.50	5.81	30.58	7.50	9.18	10.60	12.99	15.91	
175	652	701	702	703	704	●	29	0.118	1.75	6.78	35.68	8.75	10.72	12.38	15.16	18.56	
20	652			723	724	●	29	0.120	2.00	7.75	40.78	10.00	12.25	14.14	17.32	21.21	
25	652			763	764	●	29	0.138	2.50	9.68	50.97	12.50	15.31	17.68	21.65	26.52	
30	652			793		●	29	0.153	3.00	11.62	61.16	15.00	18.37	21.21	25.98	31.82	

Conversion formula for this series: $\dot{V}_2 = \dot{V}_1 \cdot \sqrt{\frac{p_2}{p_1}}$



Assembly accessories can be found in Chapter 12 "Accessories".

Ordering example: 652 + 361 + A3 + 29 = Ordering no. = 652.361.A3.29

High pressure flat fan nozzles

Series 6FH with spray stabilizer

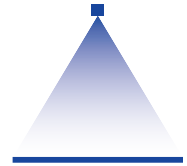

Features:

- Sharp, uniform flat fan spray
- Extremely narrow spray depth
- Nozzle with spray stabilizer
- Housing: Stainless steel 303, Insert: Hardened stainless steel 420F, spray stabilizer: Stainless steel 301



Series 6FH

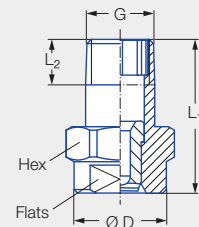

Figure 1

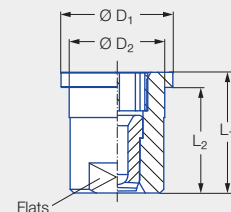

Figure 2

Applications:

- High pressure cleaning

Figure	G	Dimensions [in]							Weight [lb]	p _{max} ¹ [psj]
		L ₁	L ₂	Ø D	Ø D ₁	Ø D ₂	Hex (mm)	Flats (mm)		
1	1/8 BSPT	0.87	0.26	0.51	–	–	14	10	0.03	approx. 10,153
1	1/8 NPT	0.87	0.26	0.51	–	–	14	10	0.03	approx. 10,153
1	1/4 BSPT	0.87	0.39	0.51	–	–	14	10	0.04	approx. 10,153
1	1/4 NPT	0.87	0.40	0.51	–	–	14	10	0.04	approx. 10,153
2	–	0.63	0.55	–	0.58	0.50	–	10	0.03	approx. 4,351

¹ Applies only to operation at constant pressure.

Series	Ordering number				Mat. No. A3 Stainless steel 303/420F/301	Equivalent bore diameter A [in]	V̇ water [gal/min]							
	Flow rate code						p [psi]							
	Spray angle						40	600	liters per minute 80 bar	1000	1500	2000	3000	4500
	20°	30°	45°	60°										
6FH	361	362	363	364	●	0.039	0.20	0.77	4.08	1.00	1.22	1.41	1.73	2.12
6FH	371	372	373	374	●	0.040	0.21	0.81	4.28	1.05	1.29	1.49	1.82	2.23
6FH	381	382	383	384	●	0.043	0.25	0.97	5.10	1.25	1.53	1.77	2.16	2.65
6FH	391	392	393	394	●	0.046	0.28	1.09	5.71	1.40	1.72	1.98	2.43	2.97
6FH	401	402	403	404	●	0.047	0.30	1.16	6.11	1.50	1.84	2.12	2.60	3.18
6FH	411	412	413	414	●	0.051	0.34	1.32	6.93	1.70	2.08	2.40	2.94	3.61
6FH	441	442	443		●	0.052	0.38	1.47	7.75	1.90	2.33	2.69	3.29	4.03
6FH	451	452	453	454	●	0.053	0.40	1.55	8.16	2.00	2.45	2.83	3.47	4.25
6FH	461	462			●	0.054	0.43	1.67	8.77	2.15	2.63	3.04	3.72	4.56
6FH	471	472	473	474	●	0.055	0.45	1.74	9.18	2.25	2.76	3.18	3.90	4.77
6FH	481	482	483	484	●	0.061	0.50	1.94	10.20	2.50	3.06	3.54	4.33	5.30
6FH	501	502	503	504	●	0.063	0.55	2.13	11.22	2.75	3.37	3.89	4.76	5.83
6FH	521	522	523	524	●	0.068	0.60	2.32	12.24	3.00	3.67	4.24	5.20	6.36

Series	Ordering number					Equivalent bore diameter A [in]	V̇ water [gal/min]							
	Flow rate code				Mat. No.		p [psi]							
	Spray angle						Stainless steel 303/420F/301							
	20°	30°	45°	60°	40			600	liters per minute 80 bar	1000	1500	2000	3000	4500
6FH	531	532	533	534	●	0.069		0.65	2.52	13.26	3.25	3.98	4.60	5.63
6FH	541	542	543	544	●	0.071	0.70	2.71	14.28	3.50	4.29	4.95	6.06	7.42
6FH	551	552	553	554	●	0.075	0.75	2.90	15.29	3.75	4.59	5.30	6.49	7.95
6FH	571	572	573	574	●	0.080	0.80	3.10	16.31	4.00	4.90	5.66	6.93	8.49
6FH	581	582	583	584	●	0.081	0.87	3.37	17.74	4.35	5.33	6.15	7.53	9.23
6FH	591	592	593	594	●	0.083	0.90	3.49	18.35	4.50	5.51	6.37	7.80	9.55
6FH	601	602	603	604	●	0.091	1.00	3.87	20.38	5.00	6.12	7.07	8.66	10.60
6FH	621*	622*	623*	624*	●	0.094	1.10	4.26	22.42	5.50	6.74	7.78	9.53	11.67
6FH	641*	642*	643*	644*	●	0.098	1.25	4.84	25.48	6.25	7.65	8.84	10.83	13.26
6FH	651*	652*	653*	654*	●	0.100	1.31	5.07	26.71	6.55	8.02	9.27	11.35	13.90
6FH	661*	662*	663*	664*	●	0.104	1.39	5.38	28.34	6.95	8.51	9.83	12.04	14.74
6FH	671*	672*	673*	674*	●	0.106	1.50	5.81	30.58	7.50	9.18	10.60	12.99	15.91
6FH	701*	702*	703*	704*	●	0.12	1.75	6.78	35.68	8.75	10.72	12.38	15.16	18.56
6FH			723*	724*	●	0.12	2.00	7.75	40.78	10.00	12.25	14.14	17.32	21.21
6FH			763*	764*	●	0.14	2.50	9.68	50.97	12.50	15.31	17.68	21.65	26.52
6FH			793*		●	0.15	3.00	11.62	61.16	15.00	18.37	21.21	25.98	31.82

* Only available with code CC, BC or 29.

Code	Type of connection
CA	1/8 BSPT
BA	1/8 NPT
CC	1/4 BSPT
BC	1/4 NPT
29	Assembly with retaining nut 3/8 BSPP

Bases and Caps for Mounting

Inlet NPT Male	Outlet Male	Part No.	Standard Materials: 17 ¹ 316 SS 30 Brass
1/4" 3/8"	11/16 x 16 11/16 x 16	065. 215. XX. 10 065. 211. XX. 10	
1/4" 3/8"	3/8 BSPP 3/8 BSPP	065. 215. XX. 11 065. 215. XX. 12	
Caps			Other materials available. See Accessories beginning on page 127.
To fit 11/16x16 To fit 3/8 BSPP		069. 000. XX. 00 065. 200. XX. 00	

Ordering Type + Material no. + Code = Ordering no.
example: 6FH.404 + A3 + BA = 6FH.404.A3.BA

1) We reserve the right to deliver material 316 SS or 316L SS, if we show the material code 17.

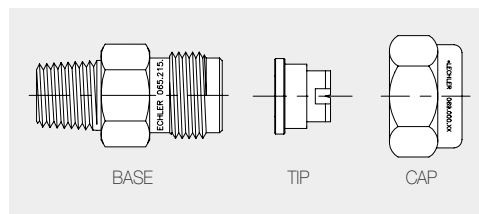

Conversion formula for this series: $\dot{V}_2 = \dot{V}_1 \cdot \sqrt{\frac{p_2}{p_1}}$



Assembly accessories can be found in Chapter 12 "Accessories".

Ordering Series + Flow rate code + Material no. + Code = Ordering no.
example: 6FH + 541 + A3 + BA = 6FH.541.A3.BA

Low pressure flat fan nozzles

Belt lubrication

Series 652

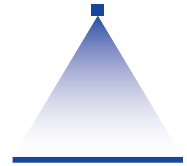

Features:

- Particularly low flow rate
- Parabolic liquid distribution
- Assembly with retaining nut

Applications:

- Belt lubrication
- Spraying on food products
- Moistening of rollers
- Oiling of metal sheets



Series 652.xxx.56.03

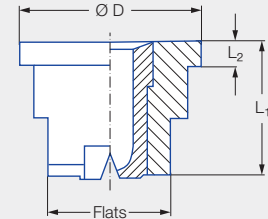

Connection	Material	Dimensions [in]				Weight [lb]
		L ₁	L ₂	Ø D	Flats (mm)	
Assembly with retaining nut 3/8 BSPP	Stainless steel 303	0.43	0.08	0.58	10	.02
	POM/Stainless steel	0.47	0.08	0.58	8	.007
	POM	0.43	0.08	0.59	8	.004

Spray angle	Type	Ordering number			Color	Narrowest free cross section Ø [in]	V̇ water [gal/min]				
		Material number					p [psi]				
		16	8H.03	56.03			15	30	45	3 bar	75
75°	652.145	●	●	●	Green	0.004	0.009*	0.013	0.016	0.06	0.021
	652.165	●	●		Black	0.005	0.012*	0.02	0.021	0.08	0.03
	652.185	●	●	●	Red	0.006	0.016*	0.02	0.03	0.10	0.035
	652.215	●	●	●	Blue	0.008	0.02*	0.03	0.04	0.14	0.05
	652.245	●	●	●	Orange	0.012	0.03*	0.04	0.05	0.20	0.07
120°	652.275	●	●		Brown	0.012	0.04*	0.06	0.07	0.27	0.09
	652.187	●	●		Grey	0.008	0.016*	0.02	0.03	0.10	0.035
	652.247	●	●		Black	0.008	0.03*	0.04	0.05	0.20	0.07
	652.277	●	●		Black	0.012	0.04*	0.06	0.07	0.27	0.09

* Differing spray pattern.

¹ We reserve the right to supply material 316Ti or 316L under material no. 17.

Accessories:

	Designation	Ordering no.	Material	Color	Pressure [psi]		G BSPP	Dimensions [in]					Mesh size [in]	
					Opening	Closing		H ₁	H ₂	Ø D	Ø D ₁	Ø D ₂		Hex
	Filter with non-return valve	095.016.53.11.00	PP	Blue	7	4	-	.83	.06	-	.59	.43	-	0.003
		095.016.53.14.63	PP	Green	41	23	-	.83	.06	-	.59	.43	-	0.003
	Flat gasket	065.240.55	PTFE	-	-	-	-	-	-	-	-	-	-	-
		065.240.72	EWP 210	-	-	-	-	-	-	-	-	-	-	-
	Retaining nut	065.200.16	Stainless steel 303	-	-	-	3/8	.51	.39	.50	-	-	22	-
		065.200.56	POM	Black	-	-	3/8	.57	.45	.51	-	-	22	-

Conversion formula for this series: $\dot{V}_2 = \dot{V}_1 \cdot \sqrt{\frac{p_2}{p_1}}$

Ordering Type + Material no. = Ordering no.
example: 652.145 + 16 = 652.145.16



Assembly accessories can be found in Chapter 12 "Accessories".

Easy Flush foam control nozzles

Series 564

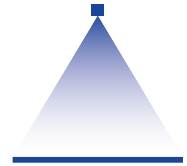

Features:

- Efficient flat fan spray
- Quick removal without complete nozzle replacement
- Reduced clogging due to larger free passage
- Reduced pumping costs due to low pressure liquid flow

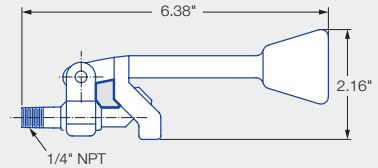
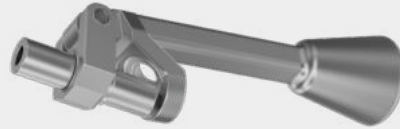

Series 564

Applications:

- Foam control in aeration tanks

Spray angle	Ordering number Connection: 1/4 " NPT Material: 316SS	Stamp	V̇ water [gal/min]						
			Pressure psi	Flow rate gpm	p [psi]				
					Width of spray coverage at elevation of nozzle above water line				
			12"	18"	24"	30"	36"		
90°	564. 846. 17. BC	1	3	1.1	22"	30"	39"	46"	54"
			5	1.4	25"	35"	44"	53"	62"
			7	1.7	27"	38"	48"	58"	68"
			10	2.0	29"	43"	53"	64"	73"
120°	564. 847. 17. BC	2	3	1.1	34"	45"	56"	66"	75"
			5	1.4	36"	49"	62"	72"	82"
			7	1.7	40"	54"	67"	79"	90"
			10	2.0	44"	60"	73"	86"	—
140°	564. 848. 17. BC	3	3	1.1	41"	57"	72"	85"	—
			5	1.4	50"	66"	82"	—	—
			7	1.7	56"	74"	92"	—	—
			10	2.0	65"	84"	—	—	—
90°	564. 916. 17. BC	4	3	1.7	23"	31"	39"	47"	56"
			5	2.1	27"	36"	45"	54"	63"
			7	2.5	29"	39"	50"	60"	70"
			10	2.9	31"	42"	54"	65"	76"
120°	564. 917. 17. BC	5	3	1.7	38"	49"	60"	70"	81"
			5	2.1	43"	57"	69"	81"	93"
			7	2.5	48"	64"	79"	93"	—
			10	2.9	56"	71"	86"	100"	—
140°	564. 918. 17. BC	6	3	1.7	50"	62"	74"	86"	—
			5	2.1	60"	73"	87"	—	—
			7	2.5	65"	78"	92"	—	—
			10	2.9	—	—	—	—	—
90°	564. 946. 32. BC	7	3	2.1	24"	33"	41"	50"	58"
			5	2.6	27"	37"	48"	58"	68"
			7	3.0	29"	40"	52"	63"	73"
			10	3.5	32"	44"	57"	69"	80"
120°	564. 947. 32. BC	8	3	2.1	45"	60"	76"	90"	—
			5	2.6	50"	66"	84"	98"	—
			7	3.0	54"	71"	90"	—	—
			10	3.5	59"	78"	100"	—	—
140°	564. 948. 32. BC	9	3	2.1	54"	67"	80"	—	—
			5	2.6	62"	75"	88"	—	—
			7	3.0	—	—	—	—	—
			10	3.5	—	—	—	—	—

¹ We reserve the right to supply material 316Ti or 316L under material no. 17.

Conversion formula for this series: $\dot{V}_2 = \dot{V}_1 \cdot \sqrt{\frac{p_2}{p_1}}$

Low pressure flat fan nozzles

Series 646

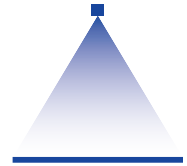

Features:

- Uniform, parabolic liquid distribution
- Adjusted spray direction
- Simple, fast manual assembly due to bayonet quick-release system

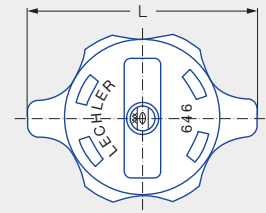

Applications:

- Belt cleaning
- Surface treatment
- Spray cleaning
- Coating processes

Series 646

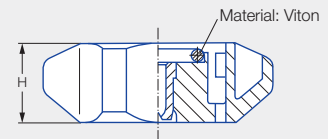

Dimensions [in]		Weight [lb]
H	L	
0.59	1.73	.03

Spray angle	Ordering number		Equivalent bore diameter A [in]	Narrowest free cross section Ø [in]	V̇ water [gal/min]							Spray width B [in] (at p = 75 psi)	
	Type	Mat. No.			p [psi]							H = 10 [in]	H = 20 [in]
		5E			liters per minute	7	15	30	45	75	5 bar		
20°	646.301	●	0.03	0.02	0.04*	0.06*	0.09	0.11	0.14	0.51	0.19	3	6
	646.361	●	0.04	0.03	0.08*	0.12*	0.17	0.21	0.27	1.00	0.37	3	6
	646.441	●	0.05	0.04	0.16*	0.24	0.34	0.41	0.53	1.98	0.74	3	6
	646.481	●	0.06	0.05	0.21*	0.30	0.43	0.53	0.68	2.53	0.95	3	6
30°	646.302	●	0.03	0.02	0.04*	0.06*	0.09	0.11	0.14	0.51	0.19	5	9
	646.362	●	0.04	0.03	0.08*	0.12*	0.17	0.21	0.27	1.00	0.37	5	9
	646.402	●	0.05	0.035	0.13*	0.19	0.27	0.33	0.42	1.58	0.59	5	9
	646.482	●	0.06	0.04	0.21*	0.30	0.42	0.53	0.68	2.53	0.95	5	9
	646.562	●	0.08	0.06	0.32	0.47	0.67	0.82	1.06	3.95	1.48	5	9
45°	646.363	●	0.04	0.02	0.08*	0.12*	0.17	0.21	0.27	1.00	0.37	7	14
	646.403	●	0.05	0.035	0.13*	0.19	0.27	0.33	0.42	1.58	0.59	8	15
	646.483	●	0.06	0.04	0.21*	0.30	0.42	0.53	0.68	2.53	0.95	8	15
	646.563	●	0.08	0.06	0.32	0.47	0.67	0.82	1.06	3.95	1.48	8	16
	646.643	●	0.10	0.07	0.52	0.76	1.07	1.32	1.70	6.32	2.36	8	16
60°	646.304	●	0.03	0.016	0.04*	0.06*	0.09	0.11	0.14	0.51	0.19	10	19
	646.334	●	0.035	0.02	0.06*	0.08*	0.12	0.15	0.19	0.71	0.27	10	19
	646.364	●	0.04	0.024	0.08*	0.12*	0.17	0.21	0.27	1.00	0.37	10	20
	646.404	●	0.047	0.03	0.13*	0.19	0.27	0.33	0.42	1.58	0.59	10	20
	646.444	●	0.05	0.035	0.17*	0.24	0.34	0.41	0.53	1.98	0.74	10	20
	646.484	●	0.06	0.04	0.21*	0.30	0.43	0.53	0.68	2.53	0.95	10	20
	646.514	●	0.065	0.043	0.25*	0.36	0.51	0.62	0.81	3.00	1.12	11	20
	646.564	●	0.08	0.05	0.32	0.47	0.67	0.82	1.06	3.95	1.48	11	21
	646.604	●	0.09	0.06	0.41	0.60	0.85	1.04	1.34	4.98	1.86	11	21

* Differing spray pattern.



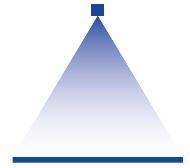

Spray angle	Ordering number		Equivalent bore diameter A [in]	Narrowest free cross section Ø [in]	V̇ water [gal/min]							Spray width B [in] (at p = 75 psi)	
	Type	Mat. No.			p [psi]							H = 10 [in]	H = 20 [in]
		5E			liters per minute	7	15	30	45	75	145		
90°	646.306	●	0.03	0.016	0.04*	0.06*	0.09	0.11	0.14	0.51	0.19	17	31
	646.336	●	0.035	0.02	0.06*	0.09*	0.12	0.15	0.19	0.71	0.27	17	32
	646.366	●	0.04	0.02	0.08*	0.12*	0.17	0.21	0.27	1.00	0.37	18	33
	646.406	●	0.047	0.028	0.13*	0.19	0.27	0.33	0.42	1.58	0.59	18	33
	646.446	●	0.05	0.03	0.17*	0.24	0.34	0.41	0.53	1.98	0.74	18	34
	646.486	●	0.06	0.03	0.21*	0.30	0.43	0.53	0.68	2.53	0.95	19	34
	646.516	●	0.065	0.035	0.25*	0.36	0.51	0.62	0.81	3.00	1.12	19	35
	646.566	●	0.08	0.04	0.32	0.47	0.67	0.82	1.06	3.95	1.48	19	35
646.606	●	0.09	0.05	0.41	0.60	0.85	1.04	1.34	4.98	1.86	20	36	
120°	646.307	●	0.03	0.01	0.04*	0.06*	0.09	0.11	0.14	0.51	0.19	28	49
	646.337	●	0.035	0.016	0.06*	0.09*	0.12	0.15	0.19	0.71	0.27	29	52
	646.367	●	0.04	0.02	0.08*	0.12*	0.17	0.21	0.27	1.00	0.37	31	53
	646.407	●	0.047	0.024	0.13*	0.19	0.27	0.33	0.42	1.58	0.59	33	55
	646.447	●	0.05	0.024	0.17*	0.24	0.34	0.41	0.53	1.98	0.74	33	56
	646.487	●	0.06	0.024	0.21*	0.30	0.43	0.53	0.68	2.53	0.95	33	56
	646.517	●	0.065	0.035	0.25*	0.36	0.51	0.62	0.81	3.00	1.12	33	56
	646.567	●	0.08	0.035	0.32	0.47	0.67	0.82	1.06	3.95	1.48	34	57
646.607	●	0.09	0.04	0.42	0.59	0.85	1.04	1.34	4.98	1.86	34	57	

* Differing spray pattern.

Assembly example

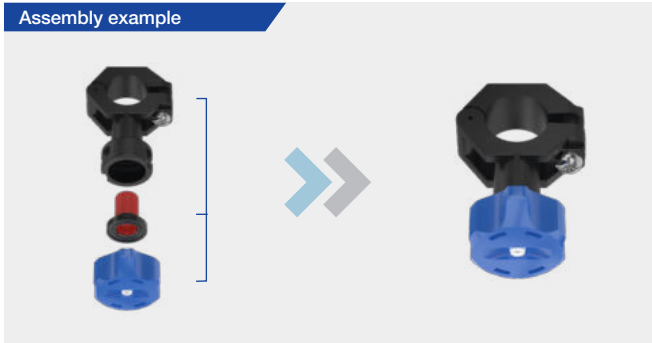

Bayonet quick-release base options for use with Series 646 nozzle



Conversion formula for this series: $\dot{V}_2 = \dot{V}_1 \cdot \sqrt{\frac{p_2}{p_1}}$

Ordering Type + Material no. = Ordering no.
example: 646.306 + 5E = 646.306*



Assembly accessories can be found in Chapter 12 "Accessories".

➤➤ Nozzle systems for surface treatment

Series 676/677 MEMOSPRAY

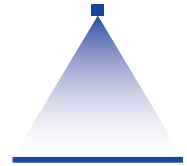

Features:

- Retention of the adjusted spray direction when changing nozzles
- Simple, quick nozzle assembly without the need for tools
- Many combination options
- Large range of flow rates, spray angles and materials

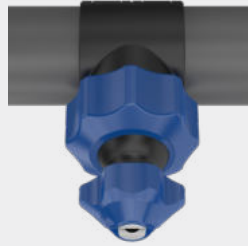

Applications:

- Degreasing
- Phosphating in surface treatment
- Industrial cleaning
- Container washers

Assembly example



① a Flat fan nozzle

Incl. gasket 095.015.7A.05.65
(Material: Viton)

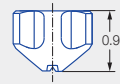

Designation	Spray angle	Ordering number				Narrowest free cross section Ø [in]	V̇ [gal/min]							Weight [lb]				
		Type	Material number				p [psi]							PP/Stainless steel 303	PP/Stainless steel 316L	PP/Ceramic	Polypropylene (PP)	
			8F	8R	E8		53	20	30	liters per minute 2 bar	40	60	80					100
① a Flat fan nozzle	30°	676.642.xx.40	●	●			0.06	1.10	1.07	4.00	1.55	1.90	2.19	2.45	0.03	0.03	-	-
		676.722.xx.40	●	●			0.08	1.38	1.69	6.30	1.95	2.39	2.76	3.09	0.03	0.03	-	-
		676.762.xx.40	●	●			0.09	1.75	2.15	8.00	2.48	3.04	3.51	3.92	0.03	0.03	-	-
		676.802.xx.40	●	●			0.10	2.19	2.69	10.00	3.10	3.80	4.39	15.81	0.03	0.03	-	-
		676.842.xx.40	●	●			0.12	2.74	3.36	12.50	3.88	4.75	5.48	6.13	0.03	0.03	-	-
		676.882.xx.40	●	●			0.13	3.51	4.30	16.00	4.96	6.08	7.02	7.85	0.03	0.03	-	-
		676.922.xx.40	●	●			0.16	4.39	5.37	20.00	6.20	7.60	8.77	9.81	0.03	0.03	-	-
		676.962.xx.40	●	●			0.17	5.48	6.72	25.00	7.76	9.50	10.97	12.26	0.03	0.03	-	-
	677.002.xx.40	●				0.19	6.91	8.46	31.50	9.77	11.97	13.82	15.45	0.03	-	-	-	
	60°	676.644.xx.40	●	●			0.06	1.10	1.07	4.00	1.55	1.90	2.19	2.45	0.03	0.03	-	-
		676.724.xx.40	●	●			0.08	1.38	1.69	6.30	1.95	2.39	2.76	3.09	0.03	0.03	-	-
		676.764.xx.40	●	●			0.09	1.75	2.15	8.00	2.48	3.04	3.51	3.92	0.03	0.03	-	-
		676.804.xx.40	●	●			0.10	2.19	2.69	10.00	3.10	3.80	4.39	15.81	0.03	0.03	-	-
		676.844.xx.40	●	●			0.12	2.74	3.36	12.50	3.88	4.75	5.48	6.13	0.03	0.03	-	-
		676.884.xx.40	●	●			0.13	3.51	4.30	16.00	4.96	6.08	7.02	7.85	0.03	0.03	0.02	0.02
		676.924.xx.40	●	●	●	●	0.16	4.39	5.37	20.00	6.20	7.60	8.77	9.81	0.03	0.03	0.02	0.02
		676.964.xx.40	●	●	●	●	0.17	5.48	6.72	25.00	7.76	9.50	10.97	12.26	0.03	0.03	0.02	0.02
		677.004.xx.40	●	●	●	●	0.19	6.91	8.46	31.50	9.77	11.97	13.82	15.45	0.03	0.03	0.02	0.02
		677.044.xx.40	●	●	●	●	0.22	8.77	10.75	40.00	12.41	15.20	17.55	19.62	0.03	0.03	-	-
		677.084.xx.40	●	●			0.24	10.97	13.43	50.00	15.51	19.00	21.94	24.52	0.03	0.03	-	-

Designation	Spray angle	Ordering number					Narrowest free cross section \varnothing [in]	\dot{V} [gal/min]							Weight [lb]			
		Type	Material number					p [psi]							PP/Stainless steel 303	PP/Stainless steel 316L	PP/Ceramic	Polypropylene (PP)
			8F	8R	E8	53		liters per minute	2 bar	40	60	80	100					
			Housing: PP Insert: 303 SS	Housing: PP Insert: 316L SS	Housing: PP Insert: Ceramic	Polypropylene (PP)								20				
① a Flat fan nozzle	90°	676.646.xx.40	●	●			0.06	1.10	1.07	4.00	1.55	1.90	2.19	2.45	0.03	0.03	-	-
		676.726.xx.40	●	●			0.08	1.38	1.69	6.30	1.95	2.39	2.76	3.09	0.03	0.03	-	-
		676.766.xx.40	●	●			0.09	1.75	2.15	8.00	2.48	3.04	3.51	3.92	0.03	0.03	-	-
		676.806.xx.40	●	●			0.10	2.19	2.69	10.00	3.10	3.80	4.39	15.81	0.03	0.03	-	-
		676.846.xx.40	●	●			0.12	2.74	3.36	12.50	3.88	4.75	5.48	6.13	0.03	0.03	-	-
		676.886.xx.40	●	●			0.13	3.51	4.30	16.00	4.96	6.08	7.02	7.85	0.03	0.03	-	-
		676.926.xx.40	●	●			0.16	4.39	5.37	20.00	6.20	7.60	8.77	9.81	0.03	0.03	-	-
	676.966.xx.40	●	●			0.17	5.48	6.72	25.00	7.76	9.50	10.97	12.26	0.03	0.03	-	-	
	120°	676.647.xx.40	●	●			0.06	1.10	1.07	4.00	1.55	1.90	2.19	2.45	0.03	0.03	-	-
		676.727.xx.40	●	●			0.08	1.38	1.69	6.30	1.95	2.39	2.76	3.09	0.03	0.03	-	-
		676.767.xx.40	●	●			0.09	1.75	2.15	8.00	2.48	3.04	3.51	3.92	0.03	0.03	-	-
		676.807.xx.40	●	●			0.10	2.19	2.69	10.00	3.10	3.80	4.39	15.81	0.03	0.03	-	-
		676.847.xx.40	●	●			0.12	2.74	3.36	12.50	3.88	4.75	5.48	6.13	0.03	0.03	-	-
		676.887.xx.40	●	●			0.13	3.51	4.30	16.00	4.96	6.08	7.02	7.85	0.03	0.03	-	-
676.927.xx.40		●	●			0.16	4.39	5.37	20.00	6.20	7.60	8.77	9.81	0.03	0.03	-	-	
Blind nozzle	-	067.630.8F.40.01	●			-	-	-	-	-	-	-	-	0.03	-	-	-	

① b Tongue-type nozzle

Incl. gasket 095.015.7A.05.65
(Material: Viton)

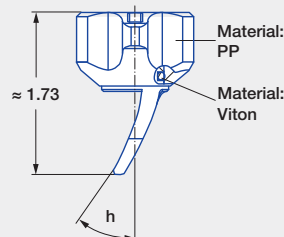

Designation	Spray angle	Deflection angle	Ordering number		Narrowest free cross section \varnothing [in]	\dot{V} [gal/min]					Weight [lb]		
			Type	Material number		p [psi]					PP/Stainless steel 316L	PVDF	
				8R		5E	liters per minute	2 bar	40	75			
				Housing: PP Insert: 316L SS		PVDF							20
① b Tongue-type nozzle	45°	35°	676.803.xx.41	●		0.13	2.19	2.69	10.00	3.10	4.25	0.05	-
	60°	35°	676.874.xx.41	●		0.17	3.29	4.03	15.00	4.65	6.37	0.05	-
	60°	35°	676.924.xx.41	●		0.19	4.39	5.37	20.00	6.20	8.50	0.05	-
	70°	40°	677.005.xx.41	●	●	0.24	6.91	8.46	31.50	9.77	13.38	0.05	0.02



Ordering Type + Material no. = Ordering no.
example: 676.646.xx.40 + 8F = 676.646.8F.40

Conversion formula for this series: $\dot{V}_2 = \dot{V}_1 \cdot \sqrt{\frac{p_2}{p_1}}$



② a Split Eyelet/ Single Clamp retaining nut

092.080.xx.00.02

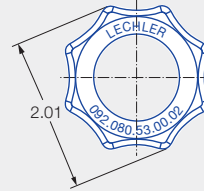
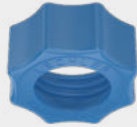

② b Eyelet Clamp Retaining Nut

067.600.xx.40

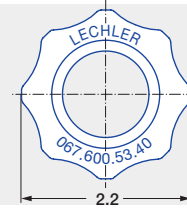

③ Split Eyelet/ Single Clamp Ball Base Bayonet

067.630.xx.40

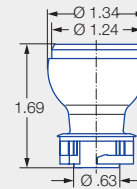

④ a Eyelet Clamp Ball Seat

067.631.xx.40.x2

For eyelet clamp
067.631.xx.40.00

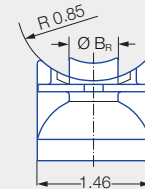

④ b Eyelet Clamp Ball Seat

067.631.xx.50.x2

For eyelet clamp
067.631.xx.50.00

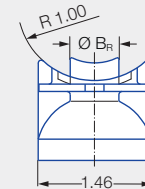

Designation	Ordering number		Ø B _r ¹ [in]	Recommended bore diameter [in]	Pipe Ø [in]	Weight [lb]
	Material number					
	53	6M				
② a Retaining nut	092.080.xx.00.02	●	-	-	-	0.04
② b Retaining nut	067.600.xx.40	●	-	-	-	0.04
③ Ball bayonet base	067.630.xx.40	●	-	-	-	0.03
④ a Ball seat for eyelet clamp no. 067.631.xx.40.00	067.631.xx.40.22	●	0.54	0.55 – 0.56	1 1/4" (1.57 – 1.69)	0.02
	067.631.xx.40.02	●	0.63	0.65 – 0.67	1 1/4" (1.57 – 1.69)	0.02
	067.631.xx.40.12	●	0.78	0.80 – 0.82	1 1/4" (1.57 – 1.69)	0.03
④ b Ball seat for eyelet clamp no. 067.631.xx.50.00	067.631.xx.50.22	●	0.54	0.55 – 0.56	1 1/2" (1.81 – 1.93)	0.02
	067.631.xx.50.02	●	0.63	0.65 – 0.67	1 1/2" (1.81 – 1.93)	0.02
	067.631.xx.50.12	●	0.78	0.80 – 0.82	1 1/2" (1.81 – 1.93)	0.03

¹ Ø B_r = spigot diameter.

ⓐ Eyelet clamp

067.631.xx.x0.00

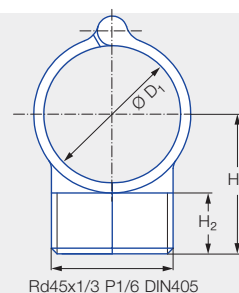
ⓑ Split Eyelet clamp

090.0x3.xx.4x.10

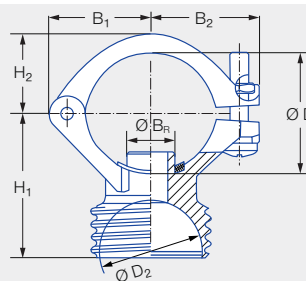
ⓒ Single clamp

092.08x.xx.00

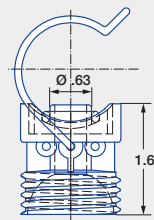

Designation	Ordering number		Dimensions [in]						Ø BR ¹ [in]	Recommended bore diameter [in]	Pipe Ø (Ø D) [in]	Weight [lb]
	Type	Material number 53	B ₁	B ₂	H ₁	H ₂	Ø D ₁	Ø D ₂				
ⓐ Eyelet clamp	067.631.xx.40.00	●							–	–	1.88	0.87
	067.631.xx.50.00	●	–	–	2.03	0.87	1.99	–	–	–	1 1/2" (1.81 – 1.93)	0.07
ⓑ Split Eyelet clamp	090.023.xx.44.10	●	1.18	1.26	1.75	0.91	–	1.34	0.54	0.55 – 0.56	1" (1.26 – 1.36)	0.11
	090.023.xx.43.10	●	1.18	1.26	1.75	0.91	–	1.34	0.63	0.65 – 0.67	1" (1.26 – 1.36)	0.11
	090.033.xx.44.10	●	1.30	1.42	1.89	1.06	–	1.34	0.54	0.55 – 0.56	1 1/4" (1.57 – 1.69)	0.11
	090.033.xx.43.10	●	1.30	1.42	1.89	1.06	–	1.34	0.63	0.65 – 0.67	1 1/4" (1.57 – 1.69)	0.11
	090.033.xx.40.10	●	1.30	1.42	1.89	1.06	–	1.34	0.79	0.81 – 0.83	1 1/4" (1.57 – 1.69)	0.11
	090.043.xx.44.10	●	1.42	1.38	2.05	1.18	–	1.34	0.54	0.55 – 0.56	1 1/2" (1.81 – 1.93)	0.11
	090.043.xx.43.10	●	1.42	1.38	2.05	1.18	–	1.34	0.63	0.65 – 0.67	1 1/2" (1.81 – 1.93)	0.11
ⓒ Single clamp	092.080.xx.00	●	–	–	–	–	–	–	0.64*	0.65 – 0.67	1" (1.26 – 1.36)	0.08
	092.081.xx.00	●	–	–	–	–	–	–	0.64*	0.65 – 0.67	1 1/4" (1.57 – 1.69)	0.08
	092.082.xx.00	●	–	–	–	–	–	–	0.64*	0.65 – 0.67	1 1/2" (1.81 – 1.93)	0.09
	092.083.xx.00	●	–	–	–	–	–	–	0.64*	0.65 – 0.67	2" (2.28 – 2.44)	0.09

* Other spigot diameters available on request.

¹ Ø BR = spigot diameter.

Ordering Type + Material no. = Ordering no.
 example: 067.631.xx.40.00 + 53 = 067.631.53.40.00

Conversion formula for this series: $\dot{V}_2 = \dot{V}_1 \cdot \sqrt{\frac{p_2}{p_1}}$

➤➤ Nozzle systems for surface treatment

Series 676 Easy-Clip

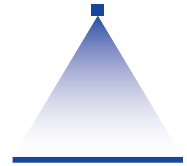

Features:

- Simple, quick nozzle assembly without the need for tools
- All-round 30° swivelling
- Easy adjustment and cleaning

Applications:

- Degreasing
- Phosphating in surface treatment
- Industrial cleaning
- Container washers

Materials:

- Clamp: Stainless steel 301
- Gasket: EPDM
- Cylinder pin, screw, screw unit: Stainless steel 316L
- Body, retaining nut: Polypropylene, glass fibre reinforced
- Ball nozzle, ball joint: Polypropylene

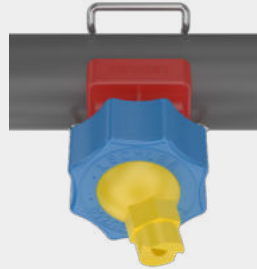

Assembly example

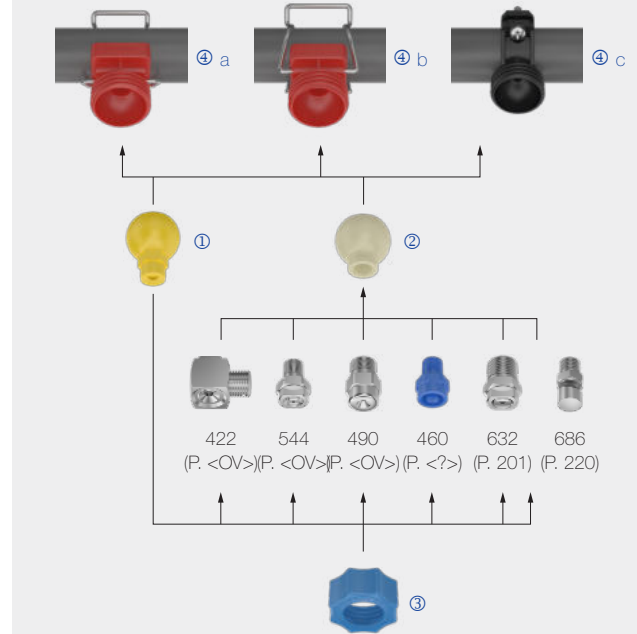

Sets – series 676 Easy-Clip

Designation	Spray angle	Ordering number	Nozzle Color	V̇ [gal/min]				
				p [psi]				
				7	15	20	liters per minute 2 bar	30
Set 1 consisting of: Ball nozzle Single clamp for 1 1/4" pipe Retaining nut	60°	676.724.53.31	Grey	0.82	1.20	1.38	6.30	1.69
		676.764.53.31	Brown	1.04	1.52	1.75	8.00	2.15
		676.804.53.31	Purple	1.30	1.90	2.19	10.00	2.69
		676.844.53.31	Yellow	1.62	2.37	2.74	12.50	3.36
		676.884.53.31	Red	2.08	3.04	3.51	16.00	4.30
		676.904.53.31	Blue	2.36	3.46	3.99	18.20	4.89
676.924.53.31	Green	2.60	3.80	4.39	20.00	5.37		

Designation	Ordering number	Ball Color	BSPP	Matches series
	Type			
Set 2 consisting of: Ball joint Single clamp for 1 1/4" pipe Retaining nut	092.081.53.AB	Beige	1/8	460, 490, 632, 686, 610, 544
	092.081.53.AD	Beige	1/4	422, 460, 490, 544, 612, 632, 686
	092.081.53.AF	Beige	3/8	422, 460, 490, 632, 686, 688
	092.081.53.AH	Beige	1/2	422, 460, 490, 632, 686

Individual parts – series 676 Easy-Clip

① Ball nozzle

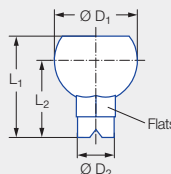

Dimensions [in]				
L ₁	L ₂	Ø D ₁	Ø D ₂	Flats (mm)
1.63	1.24	1.34	0.59	16.0

Designation	Spray angle	Ordering number Type	Nozzle Color	V̇ [gal/min]				
				p [psi]				
				7	15	20	liters per minute 2 bar	30
① Ball nozzle	60°	676.724.53.30.01	Grey	0.82	1.20	1.38	6.30	1.69
		676.764.53.30.01	Brown	1.04	1.52	1.75	8.00	2.15
		676.804.53.30.01	Purple	1.30	1.90	2.19	10.00	2.69
		676.844.53.30.01	Yellow	1.62	2.37	2.74	12.50	3.36
		676.884.53.30.01	Red	2.08	3.04	3.51	16.00	4.30
		676.904.53.30.01	Blue	2.36	3.46	3.99	18.20	4.89
676.924.53.30.01	Green	2.60	3.80	4.39	20.00	5.37		
Blind nozzle	–	092.080.53.00.01	Grey	–	–	–	–	–

② Ball joint

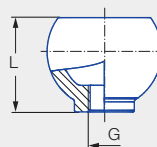

Designation	Ordering number	Ball Color	BSPP	L [in]	Matches series
	Type				
② Ball joint	092.080.53.AB.01	Beige	1/8	1.12	460, 490, 632, 686, 610, 544
	092.080.53.AD.01*	Beige	1/4	1.28	422, 460, 490, 544, 612, 632, 686
	092.080.53.AF.01*	Beige	3/8	1.24	422, 460, 490, 632, 686, 688
	092.080.53.AH.01	Beige	1/2	1.30	422, 460, 490, 632, 686

* Also available with NPT connection

③ Retaining nut

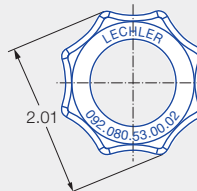
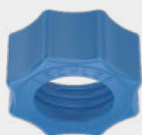

Designation	Ordering number
	Type
③ Retaining nut	092.080.53.00.02



➤➤ Nozzle systems for surface treatment

Series 676 Easy-Clip

④ a Single clamp

092.08x.53.00

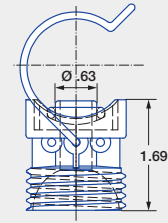

④ b Double clamp

092.09x.53.00

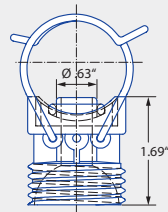

④ c Eyelet clamp

090.0x3.53.43.10

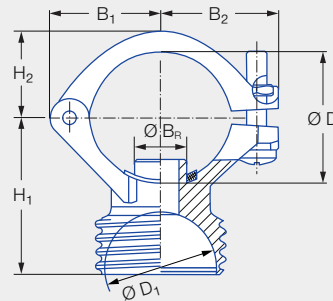

Designation	Ordering number	Dimensions [in]					Ø B _R ¹ [in]	Recommended bore diameter [in]	Pipe Ø (Ø D) [in]	Weight [lb]
		Type	B ₁	B ₂	H ₁	H ₂				
④ a Single clamp	092.080.53.00	–	–	–	–	–	0.64*	0.65 – 0.67	1" (1.26 – 1.36)	0.08
	092.081.53.00	–	–	–	–	–	0.64*	0.65 – 0.67	1 1/4" (1.57 – 1.69)	0.08
	092.082.53.00	–	–	–	–	–	0.64*	0.65 – 0.67	1 1/2" (1.81 – 1.93)	0.09
	092.083.53.00	–	–	–	–	–	0.64*	0.65 – 0.67	2" (2.28 – 2.44)	0.09
④ b Double clamp	092.090.53.00	–	–	–	–	–	0.64*	0.65 – 0.67	1" (1.26 – 1.36)	0.10
	092.091.53.00	–	–	–	–	–	0.64*	0.65 – 0.67	1 1/4" (1.57 – 1.69)	0.11
	092.092.53.00	–	–	–	–	–	0.64*	0.65 – 0.67	1 1/2" (1.81 – 1.93)	0.11
	092.093.53.00	–	–	–	–	–	0.64*	0.65 – 0.67	2" (2.28 – 2.44)	0.11
④ c Eyelet clamp	090.023.53.43.10	1.18	1.26	1.75	0.91	1.34	0.64*	0.65 – 0.67	1" (1.26 – 1.36)	0.11
	090.033.53.43.10	1.30	1.42	1.89	1.06	1.34	0.64*	0.65 – 0.67	1 1/4" (1.57 – 1.69)	0.11
	090.043.53.43.10	1.42	1.38	2.05	1.18	1.34	0.64*	0.65 – 0.67	1 1/2" (1.81 – 1.93)	0.11

¹ Ø B_R = spigot diameter.

* Other spigot diameters available upon request



➤➤ SOLID STREAM NOZZLES

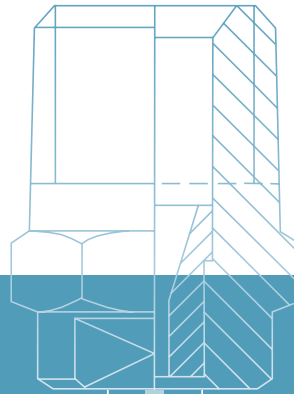

» SOLID STREAM NOZZLES OVERVIEW OF TYPES



Lechler solid stream nozzles are characterized by a stable and powerful jet stream, with low pressure and high pressure variants available. When concentrated spray power is required, e.g. in cleaning processes, the precision of Lechler solid stream nozzles enhances the productivity and performance for every installation.

Low pressure and high pressure solid stream nozzles



- Concentrated solid jet stream, minimal atomization
- High impact
- Suitable for cleaning and washing processes
- Injection
- Targeted cooling
- Pasteurization

Solid stream
nozzles

International nozzle code







High pressure solid stream nozzle designations are governed by international standards. The two digits specify the flow rate in US gallons per minute at 40 psi. Our high pressure solid stream nozzles (series 546/548/550) are specified with this international nozzle code.

02





→ Flow rate in US gal/min at 40 psi

SOLID STREAM NOZZLES OVERVIEW OF SERIES

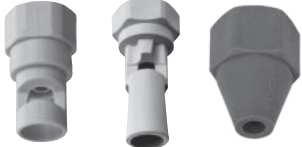

		Solid stream nozzles			
					
Series		544	546	548	550
Information on page		257	258	259	260
Pressure range	Low pressure	•			
	High pressure		•	•	•
 Flow rate	Low ≤ 5.28 gal/min	• (at p = 75 psi)	• (at p = 1160 psi)	• (at p = 1160 psi)	• (at p = 1160 psi)
	High > 5.28 gal/min		• (at p = 1160 psi)	• (at p = 1160 psi)	• (at p = 1160 psi)
 Nozzle material	Stainless steel	•	•	•	•
	Brass	•			
	Polypropylene				
 Nozzle connection		1/8 NPT 1/4 NPT	1/4 BSPT 1/4 NPT	Assembly with retaining nut 3/8 BSPP	1/8 BSPT 1/8 NPT



				
500.262 / 500.428	599.028/009 Needle Jet	599.128 Trimming	099 Screen	599.040 High Pressure
259	260	261	261	262
•				
	•	•	•	•
• (at p = 40 psi)	• (at p = 1000 psi)	• (at p = 1000 psi)		• (at p = 1000 psi)
• (at p = 60 psi)				
	•	•	•	•
•				
3/4 BSPP 3/8 BSPP	9/16"-24 NPT	1/8 NPT	Inlet 1/8 NPT Outlet 3/8 NPT	1/8"-27 Male NPT

Low pressure solid stream nozzles

Series 544

Properties:

- Concentrated solid stream jet
- High impact

Applications:

- Cleaning and washing processes
- Injection
- Targeted cooling
- Pasteurization

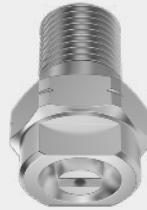

Series 544

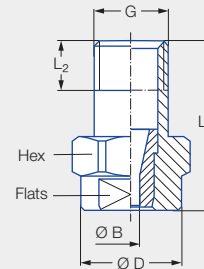

Code	G	Dimensions [in]					Weight [lb] (Brass)
		L ₁	L ₂	Ø D	Hex	Flats	
BA	1/8 NPT	0.87	0.26	0.51	9/16	10	0.03
BC	1/4 NPT	0.87	0.39	0.51	9/16	10	0.04

Type	Ordering no.		Bore diameter B [in]	V̇ water [gal/min]													
	Mat. no.			Code		p [psi]											
	16	30		1/8 NPT	1/4 NPT	7	15	30	45	60	Liters per min.	145	200	300	435		
	Stainless steel 303	Brass									5 bar						
544.110	●	●	BA	BC	0.009	0.005	0.007	0.010	0.012	0.014	0.06	0.022	0.026	0.032	0.039		
544.160	●		BA	BC	0.013	0.007	0.011	0.015	0.019	0.022	0.09	0.034	0.039	0.048	0.058		
544.200	●	●	BA	BC	0.015	0.013	0.019	0.027	0.033	0.038	0.16	0.060	0.070	0.086	0.104		
544.240	●		BA	BC	0.020	0.02	0.03	0.04	0.05	0.06	0.25	0.09	0.11	0.13	0.16		
544.280	●		BA	BC	0.025	0.03	0.05	0.07	0.08	0.10	0.40	0.15	0.18	0.21	0.26		
544.320	●	●	BA	BC	0.031	0.05	0.08	0.11	0.13	0.15	0.63	0.24	0.28	0.34	0.41		
544.360	●	●	BA	BC	0.041	0.08	0.12	0.17	0.21	0.24	1.00	0.37	0.44	0.54	0.65		
544.400	●	●	BA	BC	0.051	0.13	0.19	0.27	0.33	0.38	1.58	0.59	0.69	0.85	1.02		
544.480	●	●	BA	BC	0.052	0.21	0.30	0.43	0.52	0.61	2.53	0.94	1.11	1.36	1.64		
544.560	●	●	BA	BC	0.065	0.32	0.47	0.67	0.82	0.95	3.95	1.48	1.73	2.12	2.56		
544.640	●	●	BA	BC	0.082	0.52	0.76	1.07	1.32	1.52	6.32	2.36	2.77	3.40	4.09		
544.720	●	●	BA	BC	0.105	0.82	1.20	1.69	2.07	2.39	9.96	3.72	4.37	5.35	6.44		
544.800	●	●	BA	BC	0.130	1.30	1.90	2.69	3.29	3.80	15.81	5.91	6.94	8.49	10.23		

Conversion formula for this series: $\dot{V}_2 = \dot{V}_1 \cdot \sqrt{\frac{p_2}{p_1}}$

Ordering Type + Material no. + Code = Ordering no.
 example: 544.110 + 16 + BA = 544.110.16.BA



Assembly accessories can be found in Chapter 12 "Accessories".

High pressure solid stream nozzles

Series 546

Properties:

- Concentrated solid stream jet
- High impact
- Housing 303 SS, insert: Hardened stainless steel 420F

Applications:

- Cleaning and washing processes



Series 546

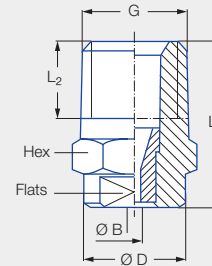

G	Dimensions [in]					Weight [lb]	p _{max} ¹ [psi]
	L ₁	L ₂	Ø D	Hex	Flats		
1/4 BSPT	0.87	0.39	0.51	9/16	10	0.04	approx. 10,150
1/4 NPT	0.87	0.39	0.51	9/16	10	0.04	approx. 10,150

¹ Applies only to operation at constant pressure.

US gal/min at 40 psi	Ordering no.		Bore diameter B [in]	V̇ water [gal/min]									
	Type	Code		p [psi]									
		1/4 BSPT		1/4 NPT	450	725	1000	Liters per min. 80 bar	1500	2000	3000	4500	
01	546.300.A3	00	07	0.024	0.34	0.43	0.50	2.04	0.61	0.71	0.87	1.06	
02	546.360.A3	00	07	0.033	0.67	0.85	1.00	4.08	1.23	1.42	1.73	2.12	
025	546.380.A3	00	07	0.037	0.84	1.06	1.25	5.10	1.53	1.77	2.17	2.65	
027	546.390.A3	00	07	0.039	0.90	1.15	1.35	5.50	1.65	1.91	2.34	2.86	
03	546.400.A3	00	07	0.040	1.01	1.28	1.50	6.12	1.84	2.12	2.60	3.18	
034	546.410.A3	00	07	0.042	1.14	1.45	1.70	6.93	2.08	2.40	2.94	3.61	
035	546.420.A3	00	07	0.044	1.17	1.49	1.75	7.14	2.14	2.48	3.03	3.71	
038	546.440.A3	00	07	0.045	1.27	1.62	1.90	7.75	2.33	2.69	3.29	4.03	
04	546.450.A3	00	07	0.047	1.34	1.70	2.00	8.16	2.45	2.83	3.47	4.25	
045	546.470.A3	00	07	0.050	1.51	1.92	2.25	9.18	2.76	3.18	3.90	4.78	
05	546.480.A3	00	07	0.052	1.68	2.13	2.50	10.20	3.06	3.54	4.33	5.31	
055	546.500.A3	00	07	0.055	1.85	2.34	2.75	11.22	3.37	3.89	4.77	5.84	
06	546.520.A3	00	07	0.057	2.01	2.56	3.00	12.24	3.68	4.25	5.20	6.37	
065	546.530.A3	00	07	0.059	2.18	2.77	3.25	13.26	3.98	4.60	5.63	6.90	
070	546.540.A3	00	07	0.062	2.35	2.98	3.50	14.28	4.29	4.95	6.07	7.43	
074	546.550.A3	00	07	0.064	2.48	3.15	3.70	15.09	4.53	5.23	6.41	7.85	
08	546.570.A3	00	07	0.067	2.68	3.41	4.00	16.31	4.90	5.66	6.93	8.49	
087	546.580.A3	00	07	0.069	2.92	3.70	4.35	17.74	5.33	6.15	7.54	9.23	
089	546.590.A3	00	07	0.070	2.99	3.79	4.45	18.15	5.45	6.29	7.71	9.44	
10	546.600.A3	00	07	0.074	3.35	4.26	5.00	20.38	6.12	7.07	8.66	10.60	
11	546.620.A3	00	07	0.078	3.69	4.68	5.50	22.42	6.73	7.78	9.52	11.66	
124	546.640.A3	00	07	0.082	4.16	5.28	6.20	25.28	7.59	8.77	10.74	13.15	
131	546.650.A3	00	07	0.085	4.39	5.58	6.55	26.71	8.02	9.26	11.35	13.90	
139	546.660.A3	00	07	0.087	4.66	5.92	6.95	28.34	8.51	9.83	12.04	14.74	
15	546.670.A3	00	07	0.090	5.03	6.39	7.50	30.58	9.19	10.61	12.99	15.91	
165	546.690.A3	00	07	0.095	5.53	7.02	8.25	33.64	10.10	11.67	14.29	17.50	
174	546.700.A3	00	07	0.098	5.84	7.41	8.70	35.47	10.65	12.30	15.07	18.45	
183	546.710.A3	00	07	0.100	6.14	7.79	9.15	37.31	11.21	12.94	15.85	19.41	
20	546.720.A3	00	07	0.105	6.71	8.52	10.00	40.78	12.25	14.14	17.32	21.22	
218	546.740.A3	00	07	0.109	7.31	9.28	10.90	44.44	13.35	15.41	18.88	23.12	
25	546.760.A3	00	07	0.117	8.39	10.64	12.50	50.97	15.31	17.68	21.65	26.52	
294	546.790.A3	00	07	0.127	9.86	12.52	14.70	59.94	18.00	20.79	25.46	31.18	
310	546.800.A3	00	07	0.130	10.40	13.20	15.50	63.20	18.98	21.92	26.85	32.88	

Conversion formula for this series: $\dot{V}_2 = \dot{V}_1 \cdot \sqrt{\frac{p_2}{p_1}}$

Ordering Type + Code = Ordering no.
example: 546.300.A3 + 00 = 546.300.A3.00



Assembly accessories can be found in Chapter 12 "Accessories".

High pressure solid stream nozzles

Series 548

Properties:

- Concentrated solid stream jet
- High impact
- Housing 303 SS, insert: Hardened stainless steel 420F
- Assembly with retaining nut

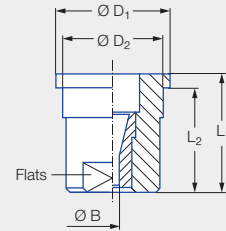

Applications:

- Cleaning and washing processes

Series 548

Code	Dimensions [in]					Weight [lb]	p _{max} ¹ [psi]
	L ₁	L ₂	Ø D ₁	Ø D ₂	Flats		
Assembly with retaining nut 3/8 BSPP	0.63	0.55	0.58	0.50	10	.03	approx. 4,350

¹ Applies only to operation at constant pressure.

Ordering no.		Bore diameter B [in]	V water [gal/min]							
US gal/min at 40 psi	Type		p [psi]							
			450	725	1000	Liters per min. 80 bar	1500	2000	3000	4500
01	548.300.A3.29	0.024	0.34	0.43	0.50	2.04	0.61	0.71	0.87	1.06
02	548.360.A3.29	0.033	0.67	0.85	1.00	4.08	1.23	1.42	1.73	2.12
025	548.380.A3.29	0.037	0.84	1.06	1.25	5.10	1.53	1.77	2.17	2.65
027	548.390.A3.29	0.039	0.90	1.15	1.35	5.50	1.65	1.91	2.34	2.86
03	548.400.A3.29	0.040	1.01	1.28	1.50	6.12	1.84	2.12	2.60	3.18
034	548.410.A3.29	0.042	1.14	1.45	1.70	6.93	2.08	2.40	2.94	3.61
035	548.420.A3.29	0.044	1.17	1.49	1.75	7.14	2.14	2.48	3.03	3.71
038	548.440.A3.29	0.045	1.27	1.62	1.90	7.75	2.33	2.69	3.29	4.03
04	548.450.A3.29	0.047	1.34	1.70	2.00	8.16	2.45	2.83	3.47	4.25
045	548.470.A3.29	0.050	1.51	1.92	2.25	9.18	2.76	3.18	3.90	4.78
05	548.480.A3.29	0.052	1.68	2.13	2.50	10.20	3.06	3.54	4.33	5.31
055	548.500.A3.29	0.055	1.85	2.34	2.75	11.22	3.37	3.89	4.77	5.84
06	548.520.A3.29	0.057	2.01	2.56	3.00	12.24	3.68	4.25	5.20	6.37
065	548.530.A3.29	0.059	2.18	2.77	3.25	13.26	3.98	4.60	5.63	6.90
070	548.540.A3.29	0.062	2.35	2.98	3.50	14.28	4.29	4.95	6.07	7.43
074	548.550.A3.29	0.064	2.48	3.15	3.70	15.09	4.53	5.23	6.41	7.85
08	548.570.A3.29	0.067	2.68	3.41	4.00	16.31	4.90	5.66	6.93	8.49
087	548.580.A3.29	0.069	2.92	3.70	4.35	17.74	5.33	6.15	7.54	9.23
089	548.590.A3.29	0.070	2.99	3.79	4.45	18.15	5.45	6.29	7.71	9.44
10	548.600.A3.29	0.074	3.35	4.26	5.00	20.38	6.12	7.07	8.66	10.60
11	548.620.A3.29	0.078	3.69	4.68	5.50	22.42	6.73	7.78	9.52	11.66
124	548.640.A3.29	0.082	4.16	5.28	6.20	25.28	7.59	8.77	10.74	13.15
131	548.650.A3.29	0.085	4.39	5.58	6.55	26.71	8.02	9.26	11.35	13.90
139	548.660.A3.29	0.087	4.66	5.92	6.95	28.34	8.51	9.83	12.04	14.74
15	548.670.A3.29	0.090	5.03	6.39	7.50	30.58	9.19	10.61	12.99	15.91
165	548.690.A3.29	0.095	5.53	7.02	8.25	33.64	10.10	11.67	14.29	17.50
174	548.700.A3.29	0.098	5.84	7.41	8.70	35.47	10.65	12.30	15.07	18.45
183	548.710.A3.29	0.100	6.14	7.79	9.15	37.31	11.21	12.94	15.85	19.41
20	548.720.A3.29	0.105	6.71	8.52	10.00	40.78	12.25	14.14	17.32	21.22
218	548.740.A3.29	0.109	7.31	9.28	10.90	44.44	13.35	15.41	18.88	23.12
25	548.760.A3.29	0.117	8.39	10.64	12.50	50.97	15.31	17.68	21.65	26.52
294	548.790.A3.29	0.127	9.86	12.52	14.70	59.94	18.00	20.79	25.46	31.18
310	548.800.A3.29	0.130	10.40	13.20	15.50	63.20	18.98	21.92	26.85	32.88

Conversion formula for this series: $\dot{V}_2 = \dot{V}_1 \cdot \sqrt{\frac{P_2}{P_1}}$



Assembly accessories can be found in Chapter 12 "Accessories".

High pressure solid stream nozzles

Series 550

Properties:

- Concentrated solid stream jet
- High impact
- Housing 303, insert: Hardened stainless steel 1.4034 S

Applications:

- Cleaning and washing processes



Series 550

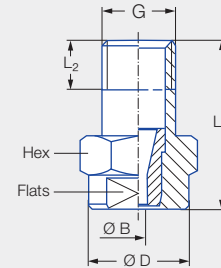

G	Dimensions [in]					Weight [lb]	p _{max} ¹ [psi]
	L ₁	L ₂	Ø D	Hex	Flats		
1/8 BSPT	0.87	0.26	0.51	9/16	10	0.03	approx. 10,150
1/8 NPT	0.87	0.26	0.51	9/16	10	0.03	approx. 10,150

¹ Applies only to operation at constant pressure.

US gal/min at 40 psi	Type	Ordering no.		Bore diameter B [in]	V water [gal/min]							
		Code			p [psi]							
		1/8 BSPT	1/8 NPT		450	725	1000	Liters per min. 80 bar	1500	2000	3000	4500
01	550.300.A3	00	07	0.024	0.34	0.43	0.50	2.04	0.61	0.71	0.87	1.06
02	550.360.A3	00	07	0.033	0.67	0.85	1.00	4.08	1.23	1.42	1.73	2.12
025	550.380.A3	00	07	0.037	0.84	1.06	1.25	5.10	1.53	1.77	2.17	2.65
027	550.390.A3	00	07	0.039	0.90	1.15	1.35	5.50	1.65	1.91	2.34	2.86
03	550.400.A3	00	07	0.040	1.01	1.28	1.50	6.12	1.84	2.12	2.60	3.18
034	550.410.A3	00	07	0.042	1.14	1.45	1.70	6.93	2.08	2.40	2.94	3.61
035	550.420.A3	00	07	0.044	1.17	1.49	1.75	7.14	2.14	2.48	3.03	3.71
038	550.440.A3	00	07	0.045	1.27	1.62	1.90	7.75	2.33	2.69	3.29	4.03
04	550.450.A3	00	07	0.047	1.34	1.70	2.00	8.16	2.45	2.83	3.47	4.25
045	550.470.A3	00	07	0.050	1.51	1.92	2.25	9.18	2.76	3.18	3.90	4.78
05	550.480.A3	00	07	0.052	1.68	2.13	2.50	10.20	3.06	3.54	4.33	5.31
055	550.500.A3	00	07	0.055	1.85	2.34	2.75	11.22	3.37	3.89	4.77	5.84
06	550.520.A3	00	07	0.057	2.01	2.56	3.00	12.24	3.68	4.25	5.20	6.37
065	550.530.A3	00	07	0.059	2.18	2.77	3.25	13.26	3.98	4.60	5.63	6.90
070	550.540.A3	00	07	0.062	2.35	2.98	3.50	14.28	4.29	4.95	6.07	7.43
074	550.550.A3	00	07	0.064	2.48	3.15	3.70	15.09	4.53	5.23	6.41	7.85
08	550.570.A3	00	07	0.067	2.68	3.41	4.00	16.31	4.90	5.66	6.93	8.49
087	550.580.A3	00	07	0.069	2.92	3.70	4.35	17.74	5.33	6.15	7.54	9.23
089	550.590.A3	00	07	0.070	2.99	3.79	4.45	18.15	5.45	6.29	7.71	9.44
10	550.600.A3	00	07	0.074	3.35	4.26	5.00	20.38	6.12	7.07	8.66	10.60
11	550.620.A3	00	07	0.078	3.69	4.68	5.50	22.42	6.73	7.78	9.52	11.66
124	550.640.A3	00	07	0.082	4.16	5.28	6.20	25.28	7.59	8.77	10.74	13.15
131	550.650.A3	00	07	0.085	4.39	5.58	6.55	26.71	8.02	9.26	11.35	13.90
139	550.660.A3	00	07	0.087	4.66	5.92	6.95	28.34	8.51	9.83	12.04	14.74
15	550.670.A3	00	07	0.090	5.03	6.39	7.50	30.58	9.19	10.61	12.99	15.91
165	550.690.A3	00	07	0.095	5.53	7.02	8.25	33.64	10.10	11.67	14.29	17.50
174	550.700.A3	00	07	0.098	5.84	7.41	8.70	35.47	10.65	12.30	15.07	18.45
183	550.710.A3	00	07	0.100	6.14	7.79	9.15	37.31	11.21	12.94	15.85	19.41
20	550.720.A3	00	07	0.105	6.71	8.52	10.00	40.78	12.25	14.14	17.32	21.22
218	550.740.A3	00	07	0.109	7.31	9.28	10.90	44.44	13.35	15.41	18.88	23.12
25	550.760.A3	00	07	0.117	8.39	10.64	12.50	50.97	15.31	17.68	21.65	26.52
294	550.790.A3	00	07	0.127	9.86	12.52	14.70	59.94	18.00	20.79	25.46	31.18
310	550.800.A3	00	07	0.130	10.40	13.20	15.50	63.20	18.98	21.92	26.85	32.88

Conversion formula for this series: $\dot{V}_2 = \dot{V}_1 \cdot \sqrt{\frac{p_2}{p_1}}$

Ordering Type + Code = Ordering no.
example: 550.300.A3 + 00 = 550.300.A3.00

Assembly accessories can be found in Chapter 12 "Accessories".

➤ Eductor nozzles

Series 500.262/500.428



- Large cross sections to minimize risk of blockage
- From 29 to 145 psi
- Tank mixing
- Liquid circulation
- Preventing sedimentation

a 500.262.53.xx

Fiberglass inforced polypropylene

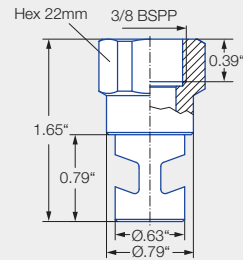

b 500.262.53.20

Polypropylene

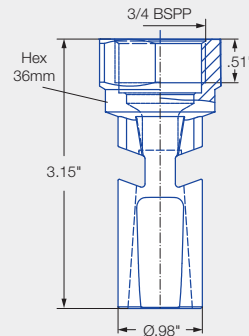

c 500.428.53.00

Fiberglass inforced polypropylene

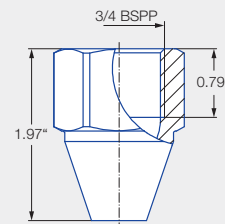

Spray angle	Ordering number Type	Orifice diam. [in.]	V̇ water [gal/min]					
			p [psi]					
			30 psi	40 psi	60 psi	Liters per min. 6 bar	80 psi	100 psi
a	500.262.53.02	0.087	1.2	1.4	1.7	7.7	2.0	2.2
	500.262.53.04	0.142	3.0	3.4	4.2	19.2	4.9	5.4
	500.262.53.06	0.177	4.9	5.7	7.0	31.8	8.1	9.0
	500.262.53.08	0.236	8.5	9.8	12.0	54.8	13.9	15.5
b	500.262.53.20	0.417	25.8	29.8	36.5	166.5	42.2	47.0
c	500.428.53.00	0.382	23.3	26.9	32.9	150.1	38.0	42.5

Other sizes on request.

» Solid stream nozzles

Series 599

Features:

- For high pressure showers
- Standard material: 316 SS
- Variant 1 for longer service life
- Variant 2 clog resistant

Applications:

- Paper production
- High pressure cleaning

Needle Jet Nozzle Series 599.009.17

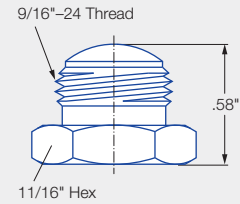
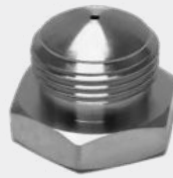

Needle Jet Nozzle with Ruby Orifice Series 599.009.8J

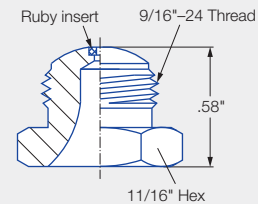

Needle Jet Nozzle with Clog Preventer Series 599.028.17

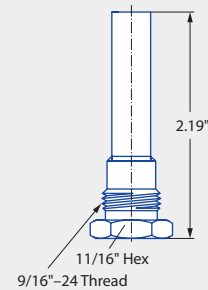

Ordering number			Orifice diameter
Standard Nozzle	Standard with Ruby Orifice***	Clog Resistant****	
599.009.17.00.14	599.009.8J.00.14	599.028.17.00.14	.014" (0.36 mm)
599.009.17.00.28	599.009.8J.00.28	599.028.17.00.28	.028" (0.71 mm)
599.009.17.00.33	599.009.8J.00.33*	599.028.17.00.33	.033" (0.84 mm)
599.009.17.00.40	599.009.8J.00.40	599.028.17.00.40	.040" (1.0 mm)
599.009.17.00.55	599.009.8J.00.55	599.028.17.00.55	.055" (1.40 mm)
599.009.17.00.70	599.009.8J.00.70**	599.028.17.00.70	.070" (1.78 mm)
599.009.17.00.94	599.009.8J.00.94	599.028.17.00.94	.094" (2.39 mm)
599.009.17.01.25	599.009.8J.01.25	599.028.17.01.25	.125" (3.18 mm)

* Actual orifice diameter of this ruby orifice nozzle is .032".

** Actual orifice diameter of this ruby orifice nozzle is .073".

*** With highly resistant ruby orifice for longer service.

**** For showers without self-cleaning features. When spraying down, the extension draws fresh water from the shower above the sediment level.

➤ Solid stream nozzles

Trimming

Series 599

Features:

- Excellent wear resistance due to ruby orifice
- Outstanding precision
- Long operational life

Applications:

- Paper production
- Trimming
- High pressure cleaning
- Jet cuttings

Trimming

- Trimming
- Weight: .05 lb.

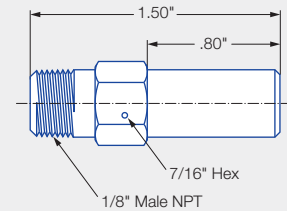

Screen 099.104.17

- Trimming
- Weight: .05 lb.

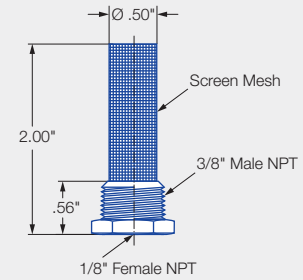

Ordering number	Orifice diam. [in.]	V water [gal/min]							
		p [psi]							
		100 psi	200 psi	300 psi	400 psi	500 psi	600 psi	800 psi	1000 psi
599.128.8J.BA.15	.015	.05	.07	.09	.10	.11	.12	.14	.16
599.128.8J.BA.20	.020	.09	.13	.16	.18	.20	.22	.25	.28
599.128.8J.BA.25	.025	.14	.20	.24	.28	.31	.34	.40	.44
599.128.8J.BA.30	.030	.20	.28	.35	.40	.45	.49	.57	.63
599.128.8J.BA.35	.035	.28	.40	.48	.56	.63	.69	.79	.89
599.128.8J.BA.40	.040	.36	.51	.62	.72	.80	.88	1.02	1.14
599.128.8J.BA.45	.045	.45	.64	.78	.90	1.01	1.10	1.27	1.42
599.128.8J.BA.50	.050	.55	.78	.95	1.10	1.23	1.35	1.56	1.74

Notice:

The ruby orifice produces a tightly collimated solid stream for precise, predictable cutting action. The optional strainer offers a convenient way to protect against clogging caused by stray fibers or loose bits of debris in your liquid supply. The ruby orifice is permanently mounted in a brass housing. The optional strainer is 316 stainless steel.

Series 599 with Screen 099



Ordering number	Meshsize
099.104.17.BE.05	50
099.104.17.BE.10	100
099.104.17.BE.20	200

Conversion formula for this series: $\dot{V}_2 = \dot{V}_1 \cdot \sqrt{\frac{p_2}{p_1}}$

High pressure Series 599



Features:

- For tight clearance installation
- Very precise, collimated stream
- Wide range of pressures
- Minimized clogging
- Facilitated cleaning
- Material 316 SS

Applications:

- Paper production
- High pressure cleaning

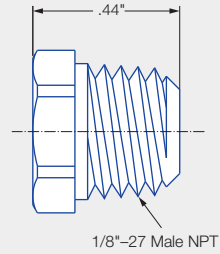
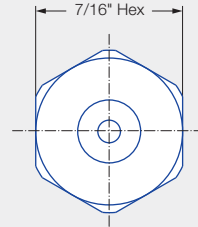

Series 599

Ordering number	Orifice Diameter
599.040.17.00.15	.015" (0.38 mm)
599.040.17.00.25	.025" (0.64 mm)
599.040.17.00.31	.031" (0.79 mm)
599.040.17.00.40	.040" (1.0 mm)

 AIR NOZZLES

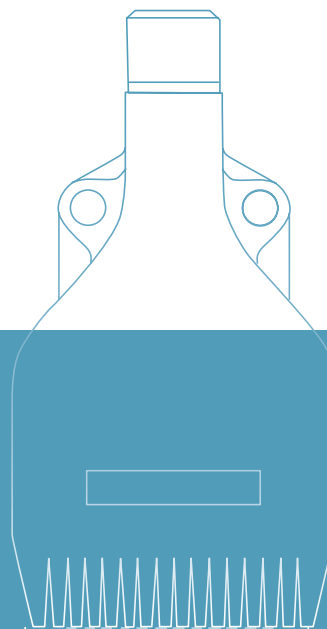

» AIR NOZZLES GENERAL INFORMATION

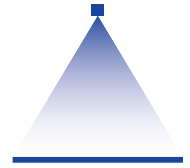

Compressed air is an indispensable tool in many areas for drying, cooling, cleaning, conveying, blowing off and much more. Lechler air nozzles make all this possible – with the highest level of precision at extraordinarily favorable conditions.

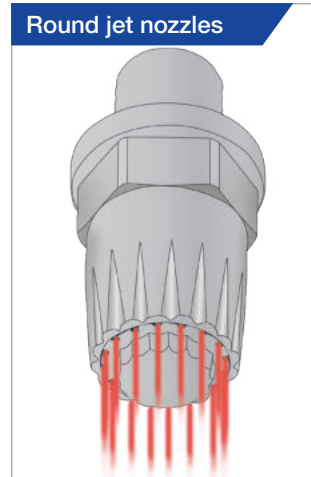
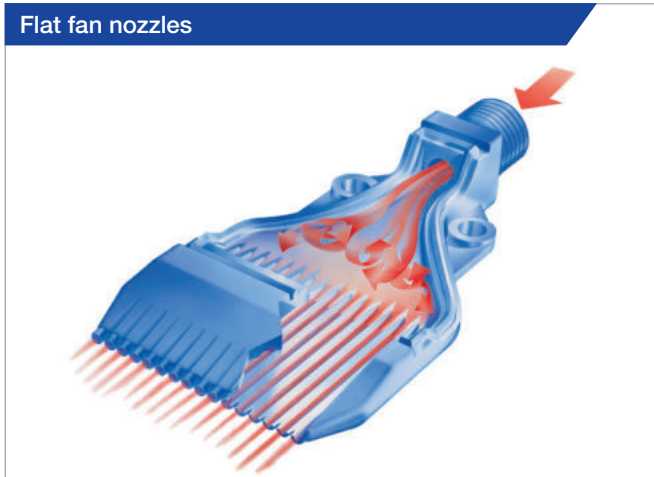

The three advantages of Lechler air nozzles for you

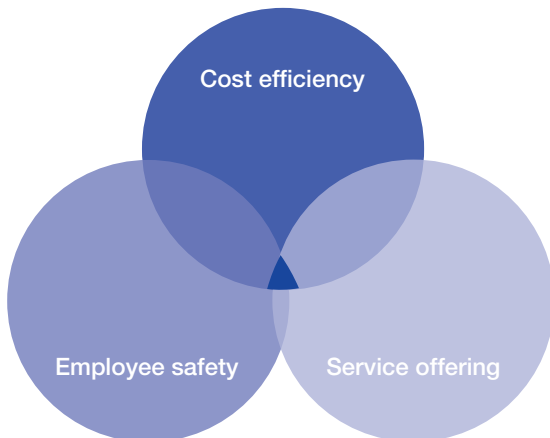

Cost efficiency

Lechler nozzles make it possible to reduce compressed air consumption by up to 45% compared to open pipes. As a result of increasing energy costs and the growing range of compressed air applications, it is not surprising that there are extremely high potential savings in this area. An advantage that will have direct positive impact on your business.

Employee safety

The unique design of our nozzles allows noise levels to be verifiably reduced by up to 25% compared to conventional solutions – thus also reducing noise-related stress for your employees. Noise levels have been confirmed to reduce concentration resulting in increased levels of stress. The use of low-noise nozzles has a positive effect on employee wellbeing and production quality.

Service offering







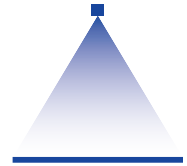

A perfect solution must be optimally tailored to your local requirements. We will, therefore, gladly advise you in person about the use of air nozzles and introduce you to new possibilities. Contact us and let us help you come up with the best possible solution for improved quality and optimized process reliability.

Good to know

Detailed information can be found in our brochure "Air nozzles" as well as at www.lechler.com/de-en/airnozzles.





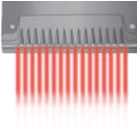

AIR NOZZLES OVERVIEW OF SERIES







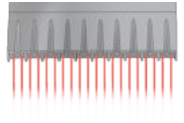
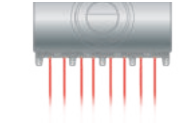







		Flat fan nozzles				
						
Series		600.130.56/S2	600.484.56	600.130.1Y	600.283.42	600.606.42
Information on page		271	272	273	274	274
Spray pattern		Multi-channel flat fan	Multi-channel flat fan	Multi-channel flat fan	Multi-channel flat fan	Multi-channel flat fan
						
Nozzle material	Plastic	●	●			
	Stainless steel			●		
	Brass					
	Zinc					
	Aluminum				●	●
Air consumption	At 30 psi	9.4 SCFM	4.7 SCFM	7.1 SCFM	10.6 SCFM	7.1 SCFM
Nozzle connection		1/4 BSPP 1/4 NPT	1/4 BSPP 1/4 NPT M12 x 1.25 Quick-release coupling size 5	1/4 BSPP 1/4 NPT	1/4 BSPP 1/4 NPT	1/4 BSPP 1/4 NPT
Maximum pressure		87 psi	87 psi	145 psi	145 psi	145 psi
Maximum temperature		PP natural: 140°F POM: 122°F	122°F	1022°F	392°F	392°F
Noise level	At 30 psi	70 dB(A)	65 dB(A)	70 dB(A)	76 dB(A)	68.5 dB(A)
Blowing force	At 30 psi	0.4 LBF	0.2 LBF	0.4 LBF	0.5 LBF	0.3 LBF

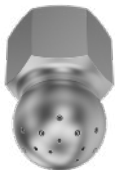

Flat fan nozzles

					
Series		600.493.1Y	600.562.1Y	679	686
Information on page		275	276	277	279
Spray pattern		Multi-channel flat fan 	Multi-channel flat fan 	Flat fan slotted nozzle 	Flat fan tongue-type nozzle 
Nozzle material	Plastic				
	Stainless steel	•	•	•	•
	Brass			•	•
	Zinc				
	Aluminum				
Air consumption	At 30 psi	17.7 SCFM	5.3 SCFM	1.8–18.2 SCFM	1.2–9.4 SCFM
Nozzle connection		1/4 BSPP 1/4 NPT	1/8 BSPP 1/8 NPT	Assembly with retaining nut 3/8 BSPP	1/8 BSPT 1/8 NPT
Maximum pressure		435 psi	435 psi	145 psi	435 psi
Maximum temperature		1022°F	122°F	1022°F (stainless steel) 434°F (brass)	1022°F (stainless steel) 434°F (brass)
Noise level	At 30 psi	78 dB(A)	71 dB(A)	67–92 dB(A)	73–84 dB(A)
Blowing force	At 30 psi	0.9 LBF	0.3 LBF		

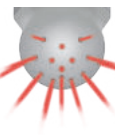
Round jet nozzles					Solid stream nozzle/Multiple solid stream nozzle	
						
600.326.5K	600.725.5K	600.326.3W	600.388.30	600.625.1Y	544	540/541
281	281	282	283	284	285	286
Multi-channel round jet	Multi-channel round jet	Multi-channel round jet	Multi-channel round jet	Multi-channel round jet	Solid stream	Multiple solid stream
						
•	•		•			
			•	•	•	•
		•				
8.8 SCFM	18.8 SCFM	8.8 SCFM	4.7 SCFM	1.2 SCFM	0.6-9.4 SCFM	20-147.7 SCFM
1/8 BSPP 1/4 BSPP 1/8 NPT 1/4 NPT M12 x 1.25	1/4 BSPP 1/4 NPT	1/4 BSPP 1/4 NPT M12 x 1.25	1/8 BSPP 1/8 NPT M12 x 1.25	M4 x 0.5 M5 x 0.5	1/8 BSPT 1/4 BSPT	1/2 BSPP 1/2 NPT
87 psi	87 psi	145 psi	145 psi	73 psi	435 psi	145 psi
122°F	122°F	194°F	122°F	1022°F	1022°F	1022°F
74 dB(A)	96 dB(A)	79 dB(A)	77 dB(A)	63-70 dB(A)	65-90 dB(A)	
0.5 LBF	0.9 LBF	0.5 LBF	0.2 LBF	0.1-0.2 LBF	0.1-0.7 LBF	

Multi-channel flat fan nozzles for air "Whisperblast", plastic version Series 600.130.56/S2

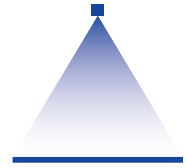

Features:

- Laminar, powerful air stream
- Low noise level (also at higher levels of pressure)

Applications:

- Blowing off and out
- Cleaning
- Drying
- Cooling
- Transporting



Series 600.130.56/S2

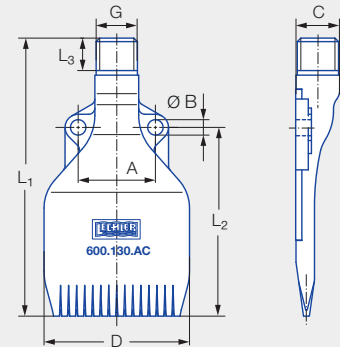

¹ Meets OSHA specifications in terms of noise level.

Cost savings and noise reduction



Cost savings

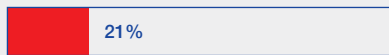

Noise reduction

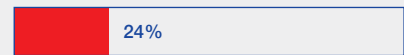

Technical data

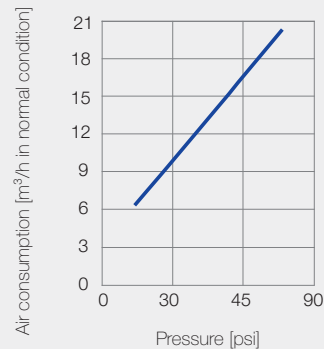
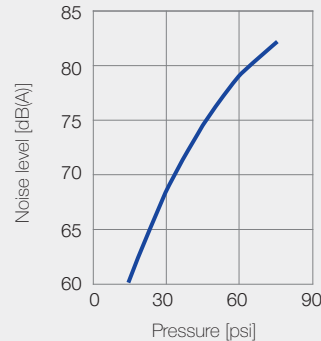
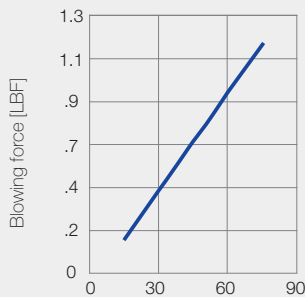

Connection	G	Dimensions [in]							Weight [lbs]
		A	C	D	L ₁	L ₂	L ₃	Ø B	
AC	1/4 BSPP	0.98	0.56	1.85	3.54	2.40	0.41	0.20	0.04
BC	1/4 NPT	0.98	0.56	1.85	3.54	2.40	0.41	0.20	0.04

Ordering number				
Type	Material number		Connection	
	56	S2	1/4 BSPP	1/4 NPT
	POM	PP natural		
600.130	●	●	AC	BC

Ordering Type + Material no. + Code = Ordering no.
example: 600.130 + 56 + BC = 600.130.56.BC



Assembly accessories can be found in Chapter 12 "Accessories".

Multi-channel flat fan nozzles for air "Whisperblast", plastic version Series 600.484.56

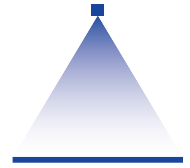

Features:

- Compact, powerful air stream
- Low noise level (also at higher levels of pressure)
- Narrow design

Applications:

- Blowing off and out
- Cleaning
- Drying
- Cooling
- Transporting

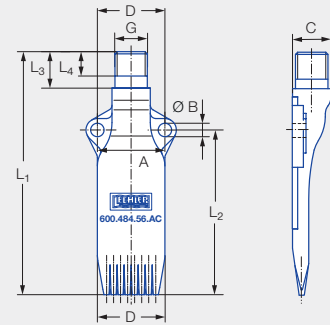

Series 600.484.56

¹ Meets OSHA specifications in terms of noise level.

Cost savings and noise reduction



Cost savings

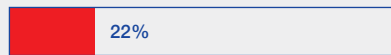

Noise reduction

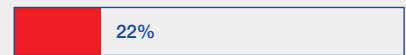

Technical data

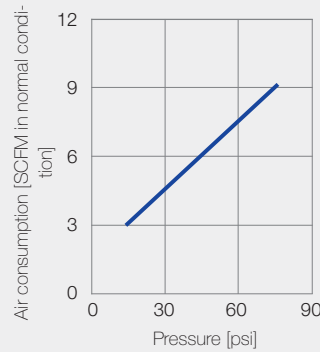
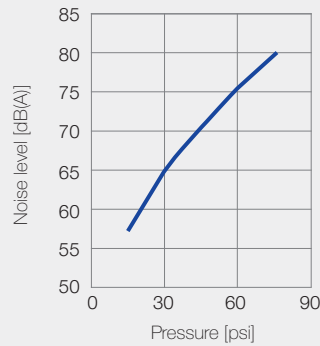
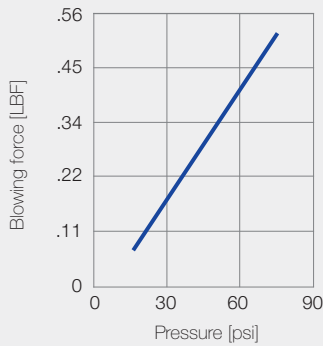

Connection	G	Dimensions [in]								Weight [lbs]
		A	C	D	L ₁	L ₂	L ₃	L ₄	Ø B	
AC	1/4 BSPP	0.98	0.56	0.98	3.54	2.40	0.53	0.35	0.20	0.04
BC	1/4 NPT	0.98	0.56	0.98	3.54	2.40	0.53	0.35	0.20	0.04
HG	M12 x 1.25	0.98	0.56	0.98	3.54	2.40	0.53	0.35	0.20	0.04
00	Quick-release coupling size 5	0.98	0.56	0.98	3.54	2.40	0.53	-	0.20	0.04

Ordering number					
Type	Material number	Connection			
	56	1/4 BSPP	1/4 NPT	M12 x 1.25	Quick-release coupling size 5
600.484	●	AC	BC	HG	00

Ordering Type + Material no. + Code = Ordering no.
example: 600.484 + 56 + BC = 600.484.56.BC



Assembly accessories can be found in Chapter 12 "Accessories".

Multi-channel flat fan nozzles for air "Whisperblast", stainless steel version Series 600.130.1Y

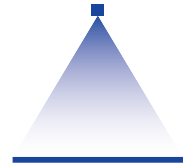

Features:

- Laminar, powerful air stream
- Low noise level (also at higher levels of pressure)
- For the highest demands

Applications:

- Blowing off and out
- Cleaning
- Drying
- Cooling
- Transporting

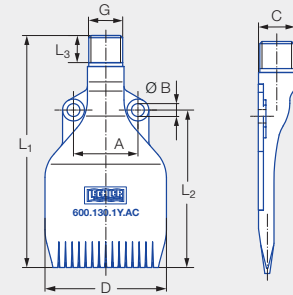

Series 600.130.1Y

¹ Meets OSHA specifications in terms of noise level.

Cost savings and noise reduction



Cost savings

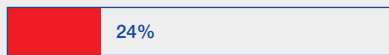

Noise reduction

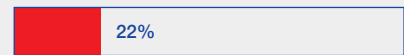

Technical data

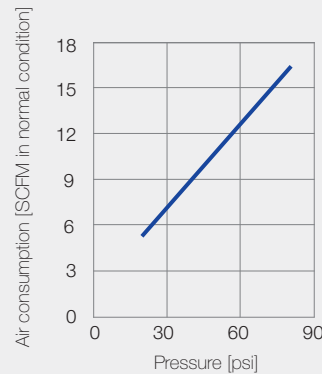
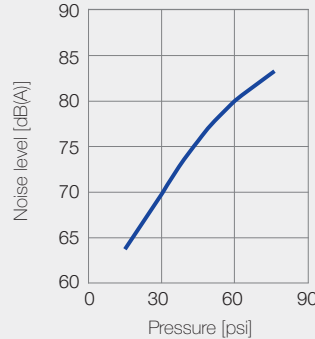
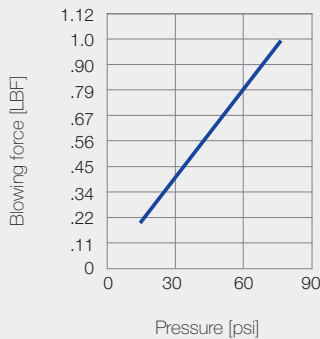

Connection	G	Dimensions [in]							Weight [lbs]
		A	C	D	L ₁	L ₂	L ₃	Ø B	
AC	1/4 BSPP	0.87	0.51	1.65	3.19	2.09	0.41	0.16	0.22
BC	1/4 NPT	0.87	0.51	1.65	3.19	2.09	0.41	0.16	0.22

Ordering number			
Type	Material number	Connection	
	1Y	1/4 BSPP	1/4 NPT
600.130	Stainless steel 316L		
	●	AC	BC

Ordering Type + Material no. + Code = Ordering no.
example: 600.130 + 1Y + BC = 600.130.1Y.BC



Assembly accessories can be found in Chapter 12 "Accessories".

Multi-channel flat fan nozzles for air "Whisperblast", metal version

Series 600.283.42/600.606.42

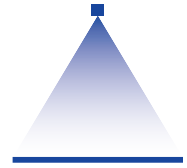

Features:

- Laminar, powerful air stream
- High blowing force
- For high thermal and mechanical requirements

Applications:

- Blowing off and out
- Cleaning
- Drying
- Cooling
- Transporting

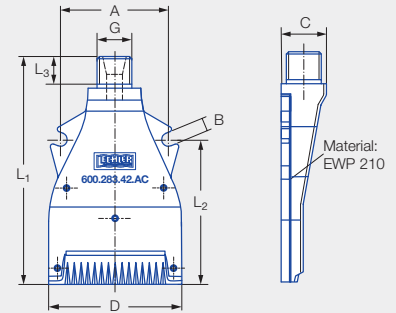

Series
600.283.42/600.606.42

¹ Meets OSHA specifications in terms of noise level.

Cost savings and noise reduction

Series 600.283/
Series 600.606



Cost savings

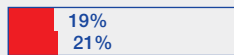

Noise reduction

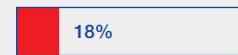

Technical data

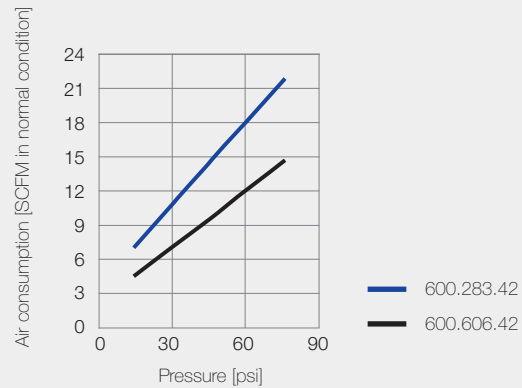
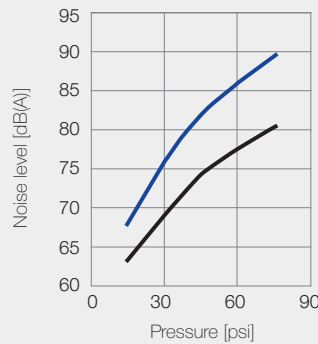
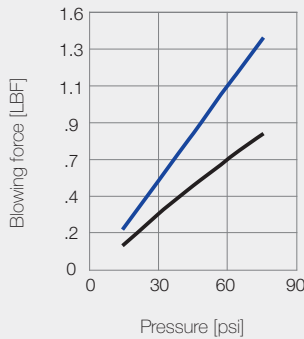

Connection	G	Dimensions [in]							Weight [lbs]
		A	B	C	D	L ₁	L ₂	L ₃	
AC	1/4 BSPP	1.61	0.20	0.67	2.01	3.41	2.17	.41	0.13
BC	1/4 NPT	1.61	0.20	0.67	2.01	3.41	2.17	.41	0.13

Ordering number			
Type	Material number	Connection	
	42	1/4 BSPP	1/4 NPT
	Aluminum		
600.283	●	AC	BC
600.606	●	AC	

Ordering example: Type 600.283 + Material no. 42 + Code BC = Ordering no. 600.283.42.BC



Assembly accessories can be found in Chapter 12 "Accessories".

Multi-channel flat fan nozzles for air "Whisperblast", stainless steel version Series 600.493.1Y

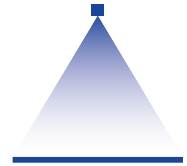

Features:

- Extremely wide, powerful air stream
- For the highest thermal requirements
- Protecting tips prevent air penetrating your skin

Applications:

- Blowing off and out
- Cleaning
- Drying

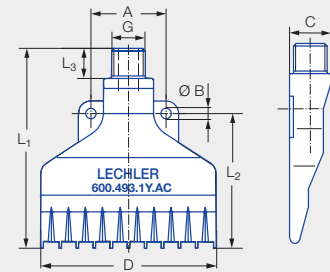

Series 600.493.1Y

Cost savings and noise reduction



Cost savings

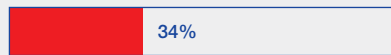

Noise reduction

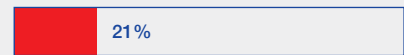

Technical data

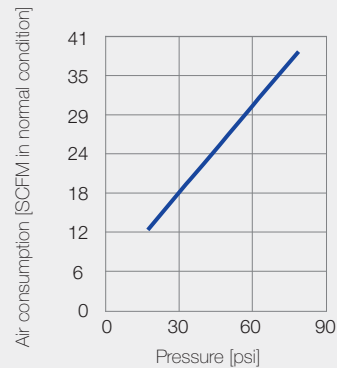
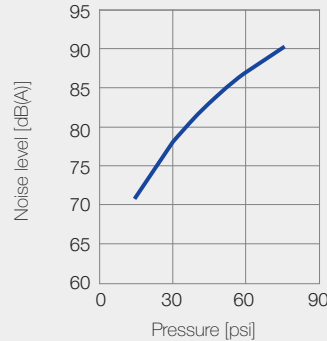
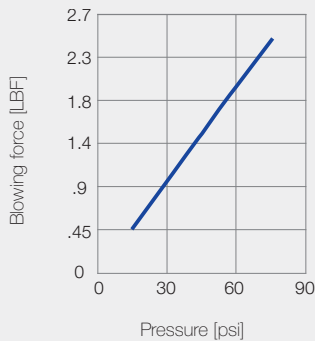

Connection	G	Dimensions [in]							Weight [lbs]
		A	C	D	L ₁	L ₂	L ₃	Ø B	
AC	1/4 BSPP	1.18	0.65	2.76	3.14	2.11	0.47	0.17	0.29
BC	1/4 NPT	1.18	0.65	2.76	3.14	2.11	0.47	0.17	0.29

Ordering number

Type	Material number		Connection	
	1Y		1/4 BSPP	1/4 NPT
	Stainless steel 316L			
600.493	●	AC	BC	

Ordering Type + Material no. + Code = Ordering no.
example: 600.493 + 1Y + BC = 600.493.1Y.BC



Assembly accessories can be found in Chapter 12 "Accessories".

Multi-channel flat fan nozzles for air "Whisperblast", stainless steel version Series 600.562.1Y

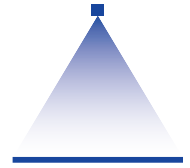

Features:

- Compact, powerful air stream
- Angled design for applications with restricted installation conditions
- Resistant to higher pressures and temperatures
- Protecting tips prevent air penetrating your skin

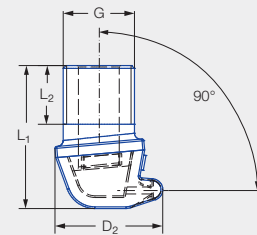
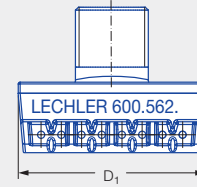
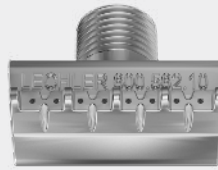

Series 600.562.1Y

Applications:

- Blowing off and out
- Cleaning
- Drying

Cost savings and noise reduction



Cost savings

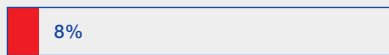

Noise reduction

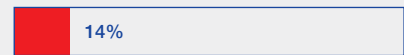

Technical data

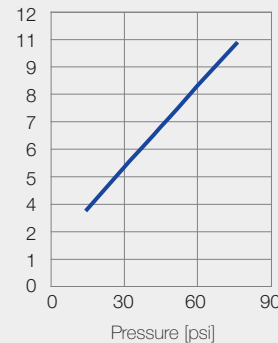
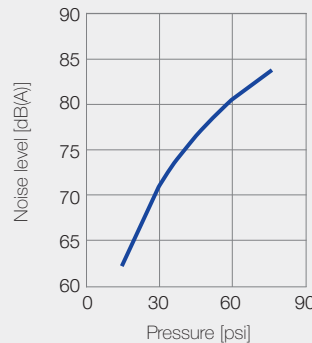
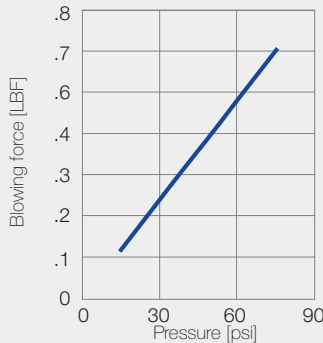

Connection	G	Dimensions [in]				Weight [lbs]
		D ₁	D ₂	L ₁	L ₂	
10	1/8 BSPP	0.98	0.58	0.77	0.31	0.04
20	1/8 NPT	0.98	0.58	0.77	0.26	0.04

Ordering number			
Type	Material number	Connection	
	1Y	1/8 BSPP	1/8 NPT
600.562	Stainless steel 316L	10	20
	●		

Ordering example: Type 600.562 + Material no. 1Y + Code 10 = Ordering no. 600.562.1Y.10



Assembly accessories can be found in Chapter 12 "Accessories".

Flat fan nozzles for air or saturated steam Series 679

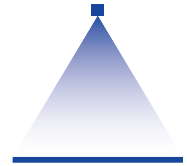

Features:

- Wide, powerful air stream
- Assembly with retaining nut
- Easy nozzle changing
- Simple jet alignment

Applications:

- Blowing off liquids
- Cooling
- Heating
- Drying

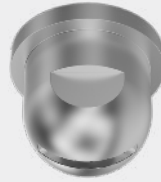

OSHA¹

FDA²

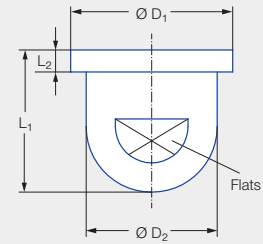

Series 679

¹ Meets OSHA specifications in terms of noise level.
² Only applies to the stainless variant.

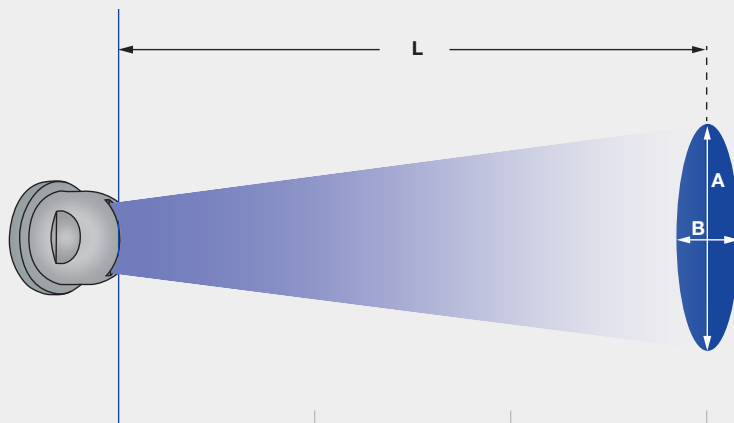

Jet pattern of series 679

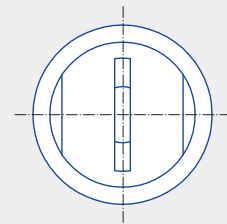

Pressure		15 psi	45 psi	75 psi
679.037	Length L [in]	1.9	3.9	5.9
	A [in]	4.3	10.2	15
	B [in]	1	1.4	1.8
679.117	Length L [in]	1.9	4.9	5.9
	A [in]	3.9	9.8	12.2
	B [in]	1	1.2	1.4
679.255	Length L [in]	14.8	20	20
	A [in]	3.5	7.5	11
	B [in]	3.5	3.5	3.5

Pressure		15 psi	45 psi	75 psi
679.415	Length L [in]	27	35	35
	A [in]	6.3	11.8	18.1
	B [in]	8.5	8.5	8.5
679.495	Length L [in]	35	35	35
	A [in]	7.9	16.1	20.1
	B [in]	9.1	9.1	9.1

Connection	Dimensions [in]					Weight [lbs] (brass)
	L ₁	L ₂	Ø D ₁	Ø D ₂	Flats	
Assembly with retaining nut 3/8 BSPP	0.51	0.08	0.58	0.83	10	0.02

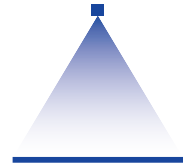

Spray angle	Ordering number			Equivalent bore diameter B [in]	\dot{V}_n air [SCFM]				\dot{M} saturated steam [lb/hr]			
	Type	Material number			p [psi]				p [psi]			
		17	30									
		Stainless steel 316Ti	Brass		7	30	75	145	7	30	75	145
Approx. 70°–90°	679.037		●	0.047	0.9	1.8	3.5	6.5	2.6	5.1	10.1	18.3
	679.085	●	●	0.051	1.2	2.4	4.7	8.7	3.5	6.8	13.4	24.4
	679.117	●	●	0.059	1.2	2.5	4.9	9.1	3.8	7.3	14.3	25.8
	679.165	●	●	0.071	1.5	3.0	6.1	11.1	4.4	9.0	17.6	31.5
	679.255	●	●	0.083	2.1	4.3	8.5	15.7	6.2	12.6	24.7	44.5
	679.365	●	●	0.110	3.7	7.5	15.0	27.4	11.0	22.0	43.1	77.7
	679.415	●	●	0.142	6.0	12.0	24.0	43.9	17.6	35.1	69.1	124.8
679.495	●	●	0.169	9.2	18.3	36.6	67.1	27.3	54.6	106.8	192.6	

Assembly example

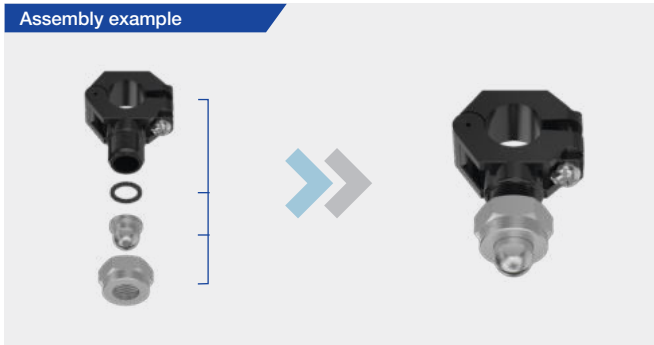

Ordering example: Type 679.037 + Material no. 30 = Ordering no. 679.037.30



Assembly accessories can be found in Chapter 12 "Accessories".

Flat fan tongue-type nozzles for air or saturated steam

Series 686

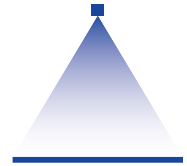

Features:

- Wide, powerful air stream
- Compact design
- Large spray width, also for short blowing distances
- Brass and stainless steel versions available for high ambient temperatures



OSHA¹

FDA²

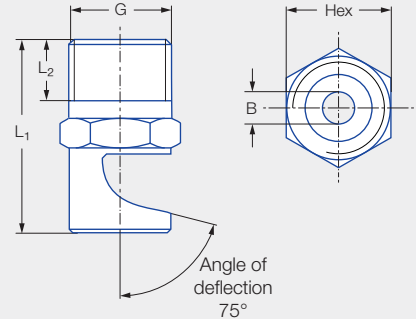

Applications:

- Blowing off liquids
- Cooling
- Heating
- Drying

Series 686

¹ Meets OSHA specifications in terms of noise level.
² Only applies to the stainless variant.

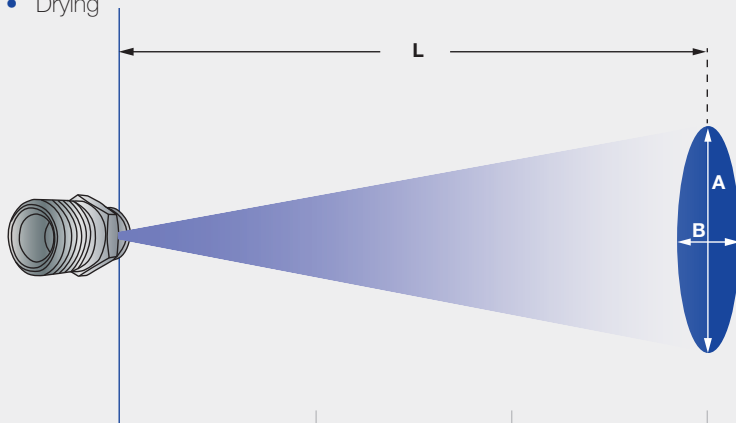

Jet pattern of series 686

Pressure		15 psi	45 psi	75 psi
686.408	Length L [in]	1.6	3.2	4.9
	A [in]	1.4	2	2.4
	B [in]	.6	1.6	2
686.528	Length L [in]	2.4	4.0	5.9
	A [in]	3	5.5	8.3
	B [in]	.8	1.6	2
686.608	Length L [in]	3.5	6.9	9.8
	A [in]	5.7	9.1	13.8
	B [in]	1	1.8	2.2

Pressure		15 psi	45 psi	75 psi
686.688	Length L [in]	6	15.8	20.7
	A [in]	9.1	22.1	29.1
	B [in]	1.6	3.2	3.9
686.728	Length L [in]	7.1	9.1	14.8
	A [in]	6.7	14.2	20.1
	B [in]	2	2	2.8

G	Dimensions [in]			Weight [lbs] (brass)
	L ₁	L ₂	Hex	
1/8 NPT	0.91	0.26	7/16	0.04

Spray angle	Angle of deflection	Ordering number				Bore diameter B (in)	V _n air [SCFM]				M saturated steam [lb/hr]			
		Type	Material number		Connection		p [psi]				p [psi]			
			16	30										
			Stainless steel 303	Brass			1/8 NPT	10	40	60	100	10	40	60
Approx. 27°–47°	75°	686.408	●	●	BA	0.039	0.4	0.8	1.1	1.7	1.8	3.5	4.6	6.6
	75°	686.488	●	●	BA	0.051	0.62	1.4	1.9	2.9	2.6	5.7	7.5	11
Approx. 70°	75°	686.528	●	●	BA	0.059	0.9	1.9	2.5	3.8	3.5	7.5	10	14
	75°	686.568	●	●	BA	0.067	1.0	2.4	3.4	5.0	4.6	10	13	19
	75°	686.608	●	●	BA	0.075	1.3	3.0	4.2	6.2	5.7	13	17	24
	75°	686.688	●	●	BA	0.094	2.2	4.7	6.6	9.9	9.0	20	26	37
	75°	686.728	●	●	BA	0.106	4.0	7.9	11	17	9.9	24	32	47
	75°	686.808	●	●	BA	0.134	6.1	13	18	27	16	39	50	74

Ordering Type + Material no. + Code = Ordering no.
 example: 686.408 + 16 + BA = 686.408.16.BA



Assembly accessories can be found in Chapter 12 "Accessories".

Multi-channel round jet nozzles for air, plastic version

Series 600.326.5K/600.725.5K

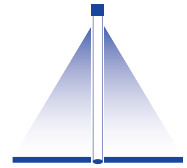

Features:

- Powerful, circular air stream
- Low noise level
- Reduced air consumption

Applications:

- Targeted blowing off and blowing out (e.g. in connection with a compressed air gun)

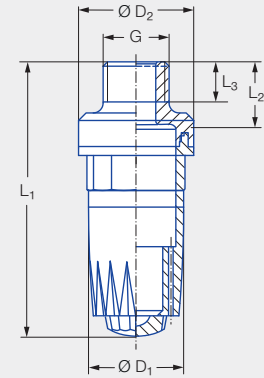

Series
600.326.5K/600.725.5K

Cost savings and noise reduction



Cost savings

9%



Noise reduction

17%

Technical data

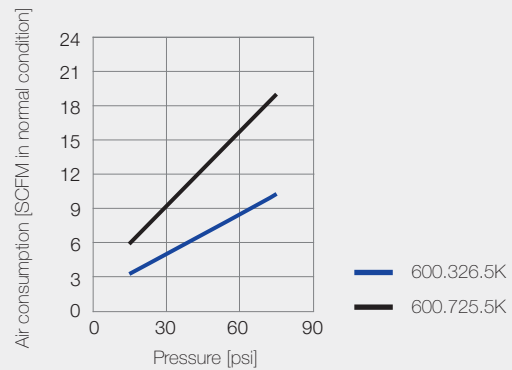
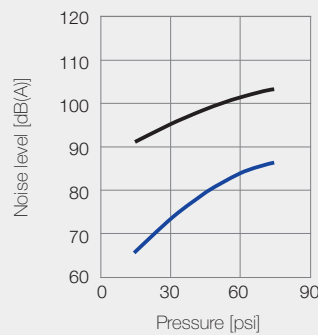
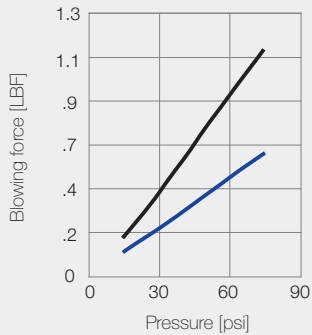

Connection	G	Dimensions [in]					Weight [lbs]
		L ₁	L ₂	L ₃	Ø D ₁	Ø D ₂	
AA	1/8 BSPP	2.13	0.37	0.24	0.75	0.91	0.02
AC	1/4 BSPP	2.17	0.40	0.31	0.75	0.91	0.02
BA	1/8 NPT	2.13	0.37	0.26	0.75	0.91	0.02
BC	1/4 NPT	2.17	0.40	0.38	0.75	0.91	0.02
HG	M12 x 1.25	2.17	0.40	0.31	0.75	0.91	0.02

Ordering number						
Type	Material number	Connection				
	ABS	1/8 BSPP	1/4 BSPP	1/8 NPT	1/4 NPT	M12 x 1.25
600.326.5K	●	AA	AC	BA	BC	HG
600.725.5K	●		AC		BC	

Ordering example: Type 600.326.5K + Code BA = Ordering no. 600.326.5K.BA



Assembly accessories can be found in Chapter 12 "Accessories".

Multi-channel round jet nozzles for air, zinc version

Series 600.326.3W

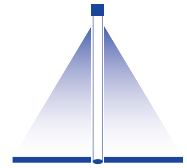

Features:

- Powerful, circular air stream
- Low noise level
- Reduced air consumption
- Zinc version: Use at high pressure and temperature levels

Applications:

- Targeted blowing off and blowing out (e.g. in connection with a compressed air gun)



Series 600.326.3W

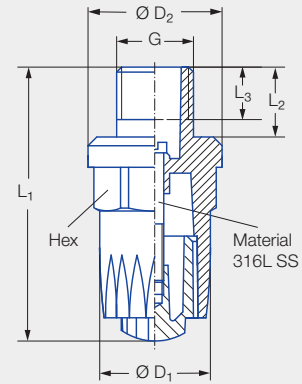

Cost savings and noise reduction



Cost savings

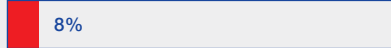

Noise reduction

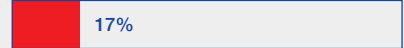

Technical data

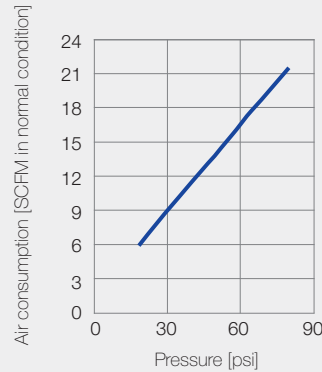
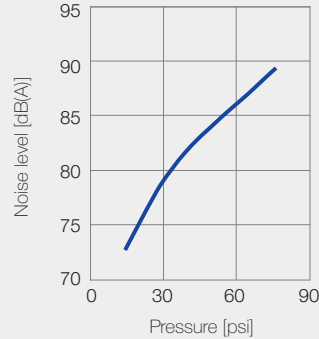
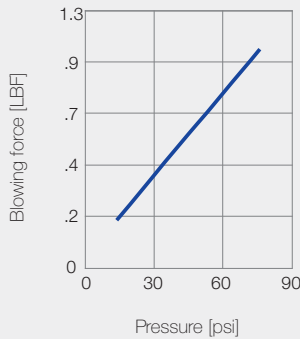

Connection	G	Dimensions [in]						Weight [lbs]
		L ₁	L ₂	L ₃	Ø D ₁	Ø D ₂	Hex	
AC	1/4 BSPP	1.85	0.47	0.35	0.75	0.91	3/4	0.11
BC	1/4 NPT	1.85	0.47	0.40	0.75	0.91	3/4	0.11
HG	M12 x 1.25	1.85	0.47	0.37	0.75	0.91	3/4	0.11

Ordering number				
Type	Material number	Connection		
	Zinc	1/4 BSPP	1/4 NPT	M12 x 1.25
600.326.3W	●	AC	BC	HG

Ordering example: Type 600.326.3W + Code BC = Ordering no. 600.326.3W.BC



Assembly accessories can be found in Chapter 12 "Accessories".

Mini multi-channel round jet nozzles for air

Series 600.388.30

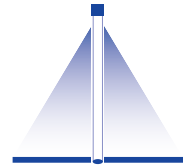

Features:

- Powerful, solid air stream for large distances
- Compact design
- Low noise level
- Reduced air consumption
- Particularly suitable for difficult-to-reach locations

Applications:

- Targeted blowing off and blowing out (e.g. in connection with a compressed air gun)

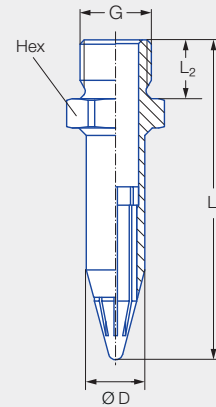

Series 600.388.30

Cost savings and noise reduction



Cost savings

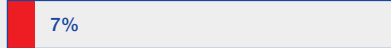

Noise reduction

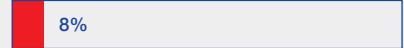

Technical data

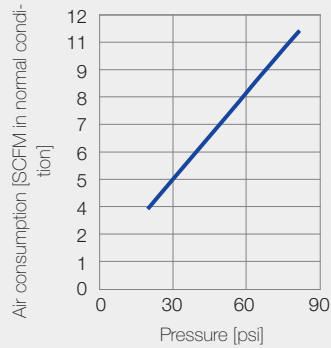
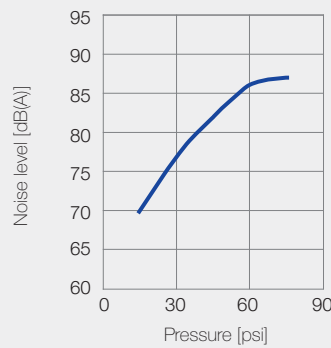
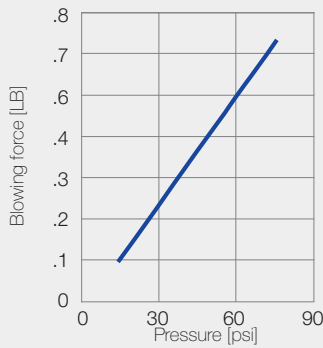

Connection	G	Dimensions [in]				Weight [lbs]
		L ₁	L ₂	Ø D	Hex	
AA	1/8 BSPP	1.71	0.31	0.31	12	0.03
BA	1/8 NPT	1.73	0.26	0.31	12	0.03
HG	M12 x 1.25	1.71	0.31	0.31	20	0.04

Ordering number				
Type	Material number	Connection		
	Brass, POM	1/8 BSPP	1/8 NPT	M12 x 1.25
600.388.30	●	AA	BA	HG

Ordering Type + Code = Ordering no.
example: 600.388.30 + BA = 600.388.30.BA



Assembly accessories can be found in Chapter 12 "Accessories".

Micro multi-channel round jet nozzles for air

Series 600.625.1Y

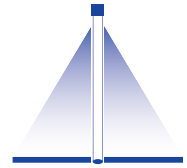

Features:

- Powerful, solid air stream
- Ultra-compact design for difficult-to-reach locations
- Low noise level
- Reduced air consumption
- For the highest thermal requirements

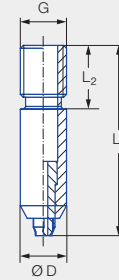

Applications:

- Targeted blowing off and blowing out

Series 600.625.1Y

Cost savings and noise reduction



Cost savings

10%



Noise reduction

6%

Technical data

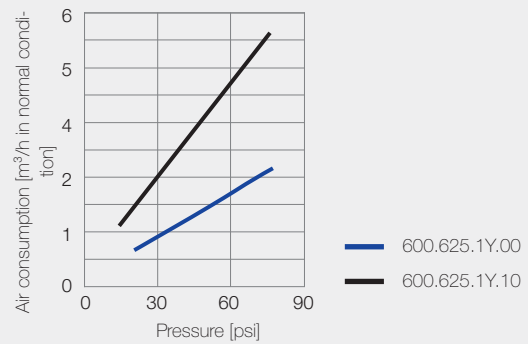
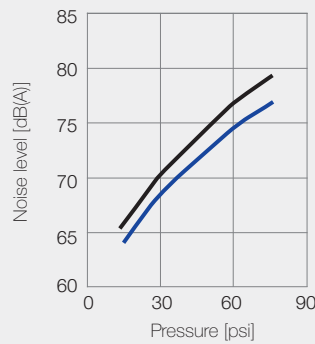
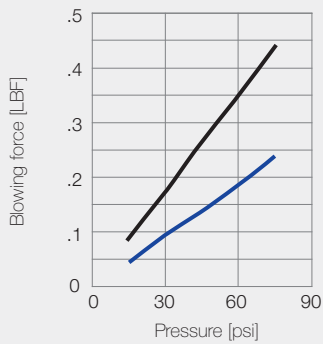

Connection	G	Dimensions [in]			Weight [lb]
		L ₁	L ₂	Ø D	
00	M4 x 0.5	0.65	0.22	0.16	0.002
10	M5 x 0.5	0.65	0.22	0.20	0.002

Ordering number			
Type	Material number	Connection	
	1Y	M4 x 0.5	M5 x 0.5
Stainless steel 316L			
600.625	●	00	10

Ordering example: Type 600.625 + Material no. 1Y + Code 00 = Ordering no. 600.625.1Y.00



Assembly accessories can be found in Chapter 12 "Accessories".

➤ Solid stream nozzles for air or saturated steam

Series 544

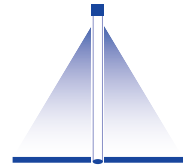

Features:

- Powerful, solid air stream
- Stainless steel version for higher ambient temperatures

Applications:

- Targeted blowing off and blowing out

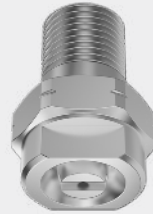

OSHA¹

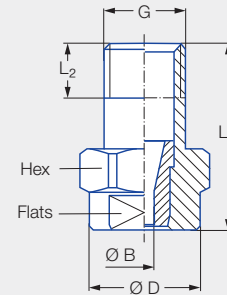

Series 544

¹ Meets OSHA specifications in terms of noise level.

Connection	G	Dimensions [in]					Weight [lbs]
		L ₁	L ₂	Ø D	Hex	Flats	
BA	1/8 NPT	0.87	0.26	0.51	14	9/16	0.03
BC	1/4 NPT	0.87	0.39	0.51	14	9/16	0.04

Ordering number				Bore diameter B [in]	V _n air [SCFM]				Ṁ saturated steam [lb/hr]			
Type	Material number	Connection			p [psi]				p [psi]			
	16	Female			10	25	50	75	10	25	50	75
		1/8 NPT	1/4 NPT									
	Stainless steel 303	1/8 NPT	1/4 NPT									
544.360	●	BA	BC	0.04	0.5	0.6	0.9	1.3	1.1	2.4	5.8	5.0
544.400	●	BA	BC	0.05	0.6	1.0	1.6	2.3	2.4	5.6	8.3	8.4
544.480	●	BA	BC	0.05	0.8	1.4	2.1	3.0	3.6	6.1	9.0	13
544.560	●	BA	BC	0.07	1.2	2.2	3.5	4.8	5.3	8.2	13	19
544.640	●	BA	BC	0.08	2.1	3.4	5.5	7.7	9.5	15	22	32
544.720	●	BA	BC	0.10	3.8	5.7	9.7	13	15	20	32	45
544.800	●	BA	BC	0.13	5.9	9.1	15	20	21	33	54	75

Ordering Type + Material no. + Code = Ordering no.
 example: 544.360 + 16 + BA = 544.360.16.BA



Assembly accessories can be found in Chapter 12 "Accessories".

Cluster solid stream nozzles for air or saturated steam

Series 540/541



Features:

- Powerful round jet through 40 individual bore holes
- Delivery of media at an angle of approx. 240°
- Suitable for use in difficult conditions
- Suitable for immersion in liquid media

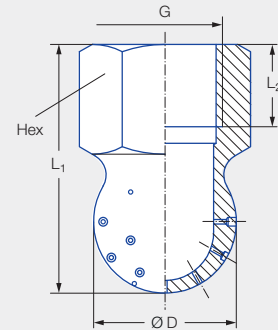
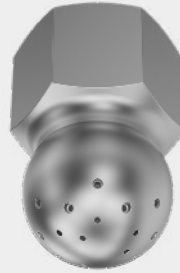

Series 540/541

Applications:

- Injection of steam into liquids
- Injection of compressed air into bulk goods
- Injection of gas (acid and neutralization baths)

G	Dimensions [in]				Weight [lbs]
	L ₁	L ₂	Ø D	Hex	
1/2NPT	1.77	0.59	1.02	27	0.22

Spray angle	Ordering number				Bore diameter B [in]	\dot{V}_n air [SCFM]				\dot{M} saturated steam [lb/hr]			
	Type	Material number	Connection			p [psi]				p [psi]			
		16	1/2 BSPP	1/2 NPT		15	30	45	75	15	30	45	75
		Stainless steel 303											
Approx. 240°	540.909	●	CG	BG	0.03	13.4	20.1	26.8	40.2	14.7	21.7	29.1	43.6
	540.989	●	CG	BG	0.04	20.9	31.4	41.8	62.7	22.9	33.7	45.4	67.9
	541.109	●	CG	BG	0.06	49.0	73.5	98.0	147.0	53.8	79.3	106.6	159.4
	541.189	●	CG	BG	0.08	76.3	114.5	152.6	229.0	83.9	123.7	166.3	248.6
	541.239	●	CG	BG	0.09	98.4	147.6	196.8	295.2	107.5	158.5	213.2	318.8

Ordering Type + Material no. = Ordering no.
 example: 540.909 + 16 = 540.909.16



Assembly accessories can be found in Chapter 12 "Accessories".

» NOZZLE-VALVE
COMBINATIONS

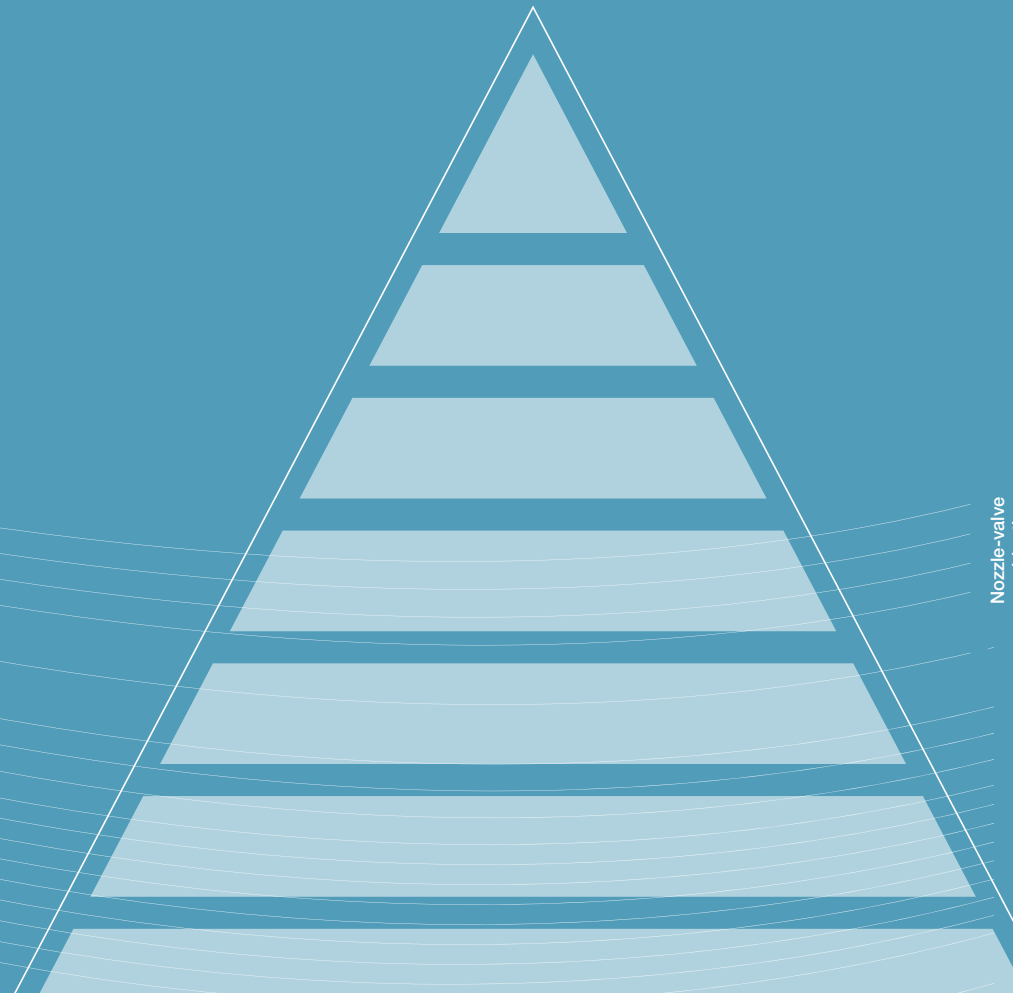
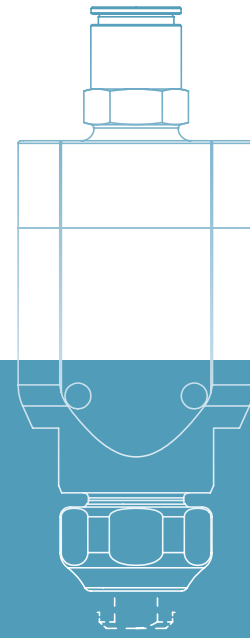

NOZZLE-VALVE COMBINATIONS

VarioSpray SYSTEMS



Innovative and flexible spraying solutions opens up new application areas.

The demand for more efficient production processes is increasing in almost every industry. Even already extremely efficient spraying technology processes are affected – particularly when spraying very small liquid volumes. Pneumatic systems are often used here, as very small flow rates can be achieved by using compressed air. However, the control and installation activities are extremely complex. Additionally, the use of air can have an unfavorable effect on operating costs. Aerosols may also be formed and liquid lost due to the rebound effect. With the VarioSpray HP and VarioSpray II hydraulic pulse-width-modulated nozzle-valve systems, Lechler offers two alternatives that are as versatile as they are reliable.

With hydraulic nozzle systems, the narrowest cross section of the spray nozzle determines the liquid flow rate. Due to economical and production-related reasons, the narrowest cross section can't be randomly minimized. Instead, we use flexible timing of the spray duration to achieve minimal flow rates – without the need for an expensive and complex pneumatic atomizing system. In addition to the VarioSpray HP and VarioSpray II nozzle-valve systems, a control unit is also required to permit simple modification of the pulse-width and cycle frequency.

Applications

- Oil application for applying seasoning
- Web humidification
- Application of separating agent
- Humidification
- Coating
- Anti-scuffing

Your advantages

- Simple adjustment of the pulse-width and the cycle frequency
- Modular design and modular system
- Start/Stop signal (e.g. via light barrier)
- Individual valve control for VarioSpray HP
- Rinsing function



Good to know

Detailed information can be found in our brochure "VarioSpray" as well as at www.lechlerusa.com/en/products/product-by-type/variospray.

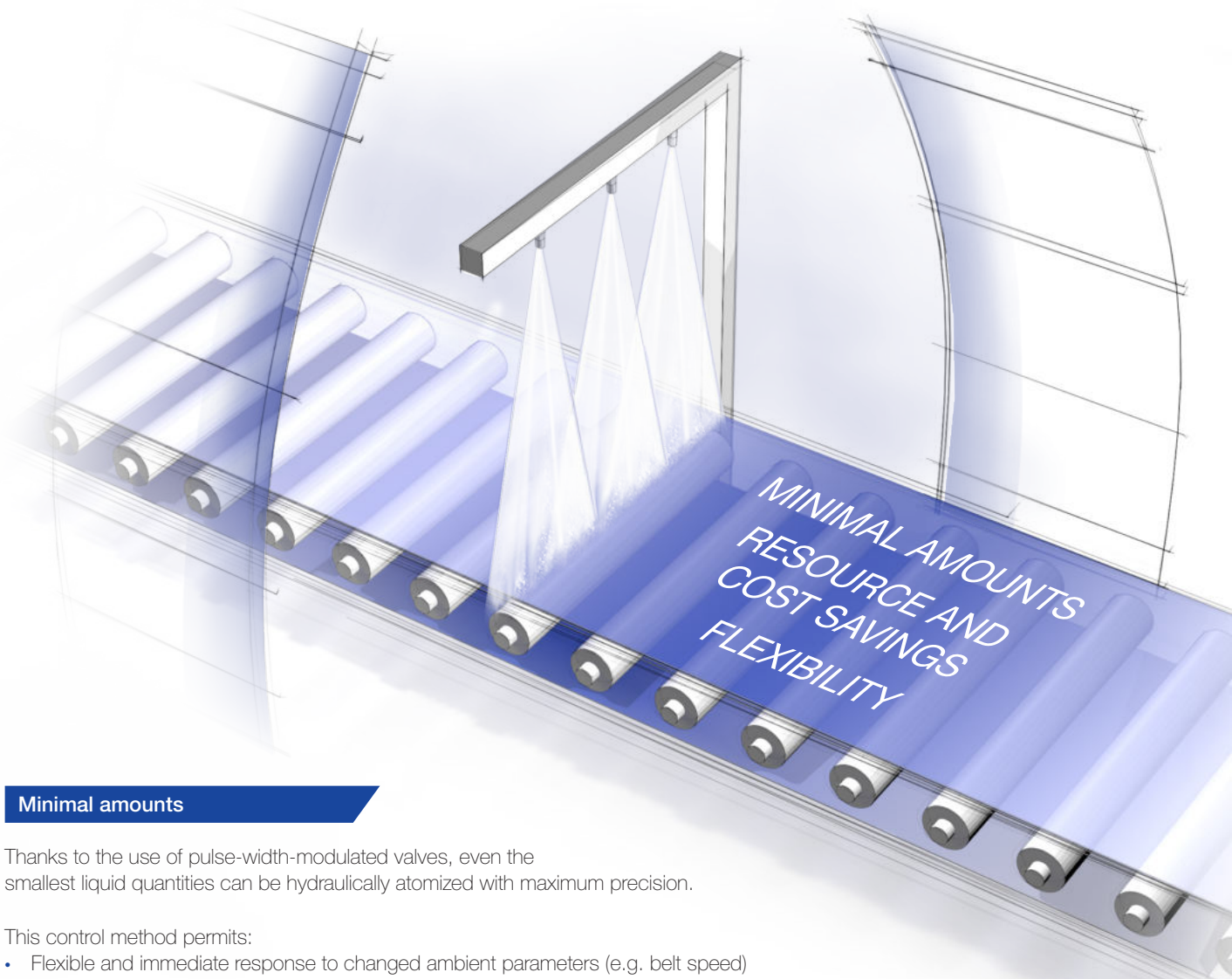

Minimal amounts

Thanks to the use of pulse-width-modulated valves, even the smallest liquid quantities can be hydraulically atomized with maximum precision.

This control method permits:

- Flexible and immediate response to changed ambient parameters (e.g. belt speed)
- Uniform jet and spray quality
- Further application benefits due to a significantly increased turn-down ratio

Resource and cost savings

The aerosol-free atomization of smallest liquid volumes offers specific benefits for spray nozzle operation. The fact that no atomizing air is used means a huge reduction in rebound effects.

The following costs are reduced as a result:

- Equipment cleaning
- Operating costs of extraction systems
- Liquid losses because the liquid being atomized is applied to the product in a more targeted manner

Flexibility

The Lechler VarioSpray system is completely modular, allowing it to be adapted to individual requirements as flexibly as possible.

The result is a perfectly coordinated product portfolio including:

- Optimum valve control due to perfectly matched electronic components
- Modular spray bars
- Various predefined Lechler control concepts
- Individual advice from our sales staff



What is pulse-width modulation?

Pulse-width modulation refers to the variation of the ON time t_{on} / OFF time t_{off} of a square-wave signal when the frequency f remains constant. Here, the frequency f corresponds to the reciprocal value of the period duration T .

The ratio of the ON time t_{on} to the period duration T is referred to as the pulse-width ratio (DC = duty cycle). The pulse-width ratio determines the flow rate. The valve is open during the ON time t_{on} . The shorter the DC, the less the flow rate. Depending on the frequency selected, the pulsation is barely visible to the human eye.

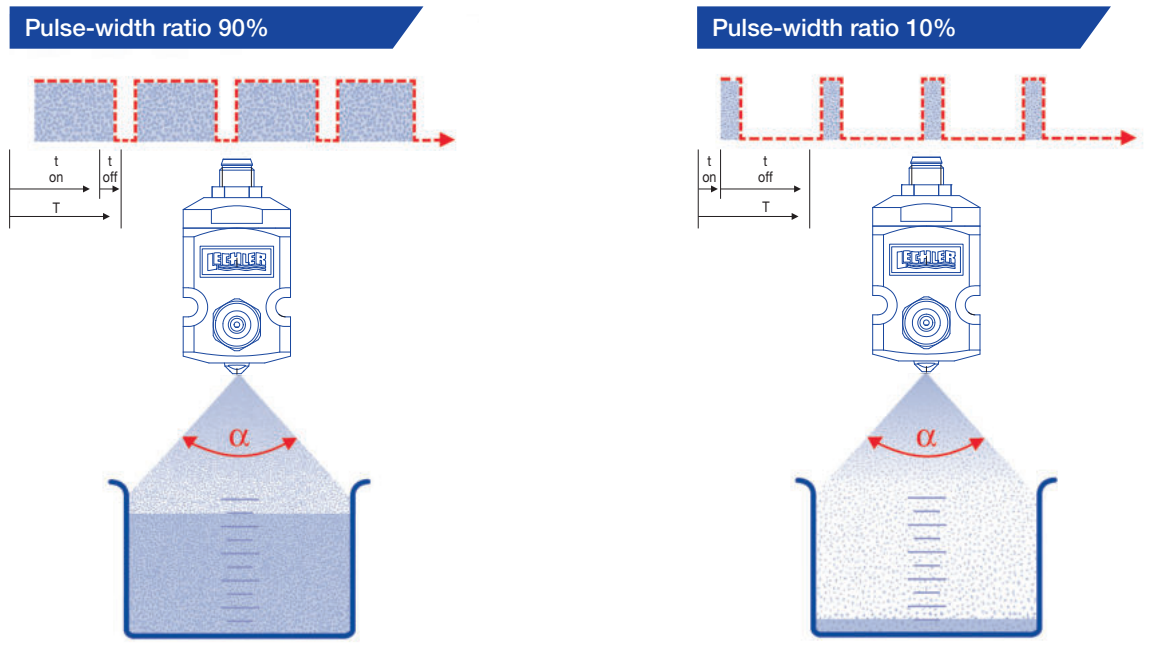

Which fluids can be sprayed?

The two innovative Lechler products VarioSpray HP and VarioSpray II can be used to precisely spray a wide range of different liquids. The two nozzle-valve systems are individually designed to optimally perform these tasks.

VarioSpray HP was developed to permit flexible spraying of a wide variety of liquids. Even high-viscosity media (up to 75 mPas, depending on the liquid density) can be easily atomized.

VarioSpray II is ideal for applying small volumes of low-viscosity, easily atomized liquids.

Sprayable liquids

VarioSpray HP	VarioSpray II
Water	
Low-viscosity separating agent	
Disinfectant	
Oils	-
Fats	-
Emulsions	-
Liquid egg	-
Milk	-
Sugar solutions	-
etc.	-

COMPARISON

VarioSpray HP – VarioSpray II



VarioSpray HP

High Performance

Flow rate: Up to 33.81 oz/min at 43.51 psi¹

For high viscosity media up to 75 mPa·s

Liquid supply at the rear

Flow-optimized liquid supply

Simple nozzle changeover

Turn-down ratio up to 29 : 1

Filter optionally available

Push-in connection for
8 mm hose diameter

Voltage 12 V DC/24 V DC for Peak & Hold
activation

Electrical connection via M8 slip-on connection

Control via colour touch panel

Two control unit versions:

- SMART (max. 8 valves)
- FLEX (max. 16 valves)

Individual valve control (FLEX)

Frequencies: 10/20/30/40/50/75/100/200 Hz

VarioSpray II

Flow rate: Up to 4.73 oz/min at 43.51 psi¹

For low viscosity media up to 15 mPa·s

Liquid supply at the side

Low liquid volume in the valve

Very small design

Turn-down ratio up to 11 : 1

Integrated last-chance filter

Push-on connection
for 6 × 1 mm hose diameter

Voltage 24 V DC

M8 slip-on connection

Compact control unit

Simple operation
(max. 8 valves)

All valves activated simultaneously

Frequencies: 25/50/75/100 Hz

¹ Nominal flow rate without nozzle.

FOR THE BEST SPRAY RESULTS

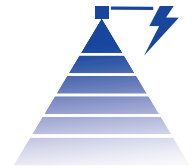

VarioSpray HP

High Performance

The HP series can be used to atomize a wide variety of liquids. All parts that come into contact with liquids are made of stainless steel, thereby complying with Directives EC 1935/2004 and FDA regulations.

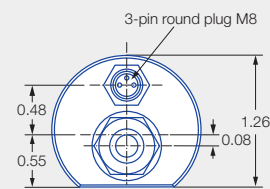
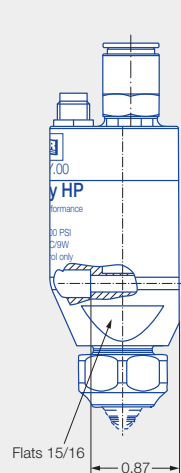
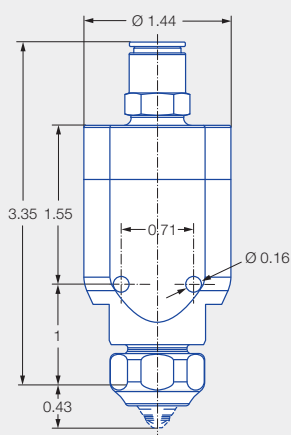

Components and combination options



Individual valve

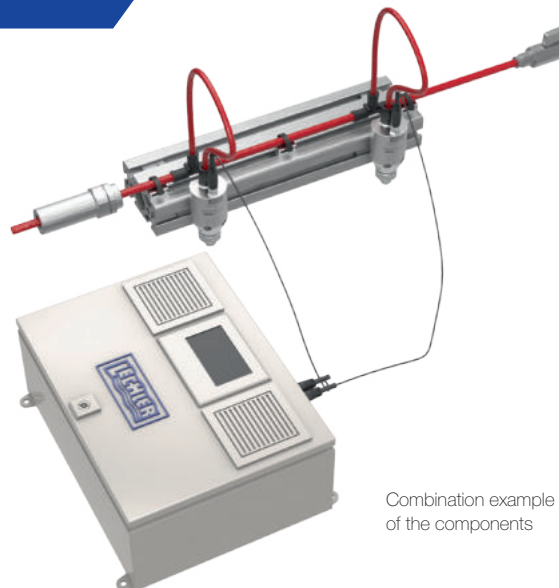

Combination example of the components

Good to know

Detailed information on VarioSpray HP along with the order numbers of the system components can be found in our brochure "VarioSpray". A PDF is available for download at www.lechlerusa.com/en/products/product-by-type/variospray

VarioSpray II

Nozzle valves of the VarioSpray II series can efficiently atomize the smallest liquid volumes. Their size makes these valves ideal for use in tight spaces. The VarioSpray II system is also available as a food grade version, thereby complying with Directives EC 1935/2004 and FDA regulations.

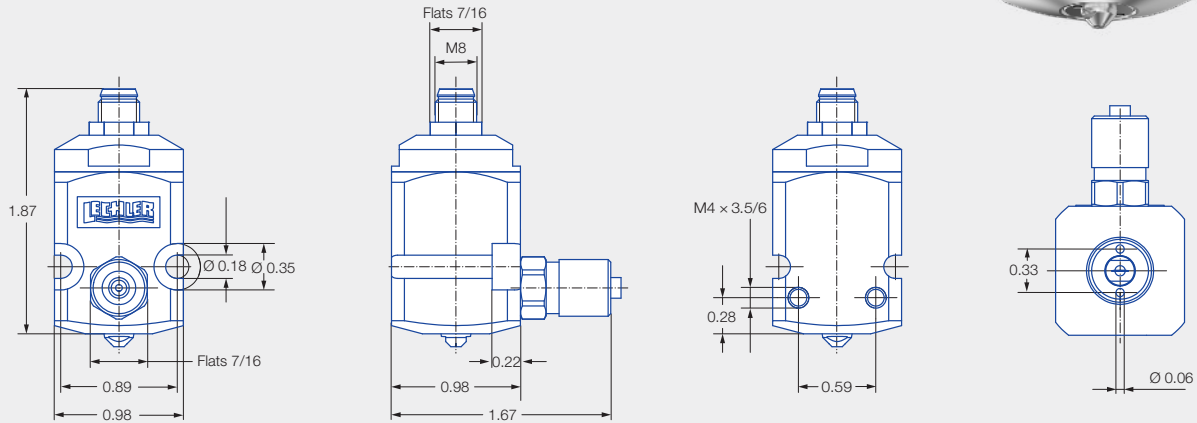
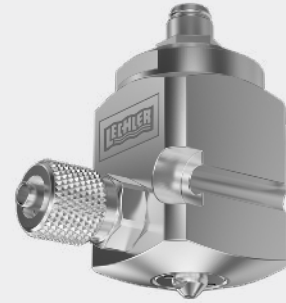

Components and combination options



Individual valve

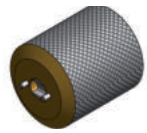

Assembly tool

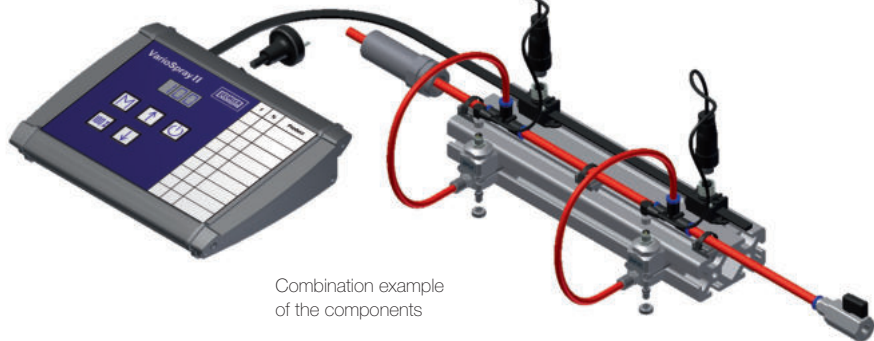

Combination example of the components

Good to know

Detailed information on VarioSpray II along with the order numbers of the system components can be found in our brochure "VarioSpray". A PDF is available for download at www.lechlerusa.com/en/products/product-by-type/variospray

NOZZLE VALVE SERIES 166H



The stainless steel housing in combination with a solenoid valve offers the possibility to clock the spray application flexibly.

Applications:

- Cleaning
- Surface treatment
- Humidification
- Lubrication processes

Scope of supply:

- Nozzle valve with housing, retaining nut and a 5 m long plugged power cable
- Nozzle must be ordered separately



Series 166H

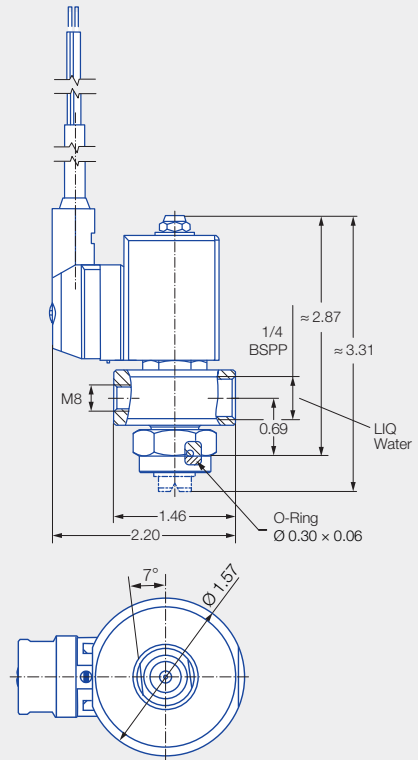

Material:

Housing: Stainless steel 316L
 Inner parts: Stainless steel 316L,
 stainless steel 304,
 stainless steel 434
 Gasket material: FKM
 (conforms to FDA)

Water flow rate:

Max. 1.7 gal/min at 75 psi

Max. operating pressure:

1,450 psi

Power:

8 W

Voltage:





24 V DC

Protection class:

IP 65

Max. switching frequency:

500/min at 75 psi

	Type	Nozzle size up to	Spray character	Spray angle/Material
	652	64x	Flat fan	Page 212
	684	608	Flat fan (tongue-type nozzle)	Page 217
	468	68x	Full cone spray	Page 174
	226	285	Hollow cone	Page 152

Your advantages

- Quick and simple nozzle assembly using a retaining nut guarantees an easy nozzle changeover
- Simple spray alignment
- Flexible design that allows the use of flat fan nozzles, hollow cone nozzles and full cone nozzles
- With integrated gasket for sealing between the nozzle and the valve

Ordering no.
166.000.1Y.H1.00.0

POSITIONABLE FLAT FAN NOZZLE FOR SERIES 166H AND VarioSpray HP



Properties:

- Outer geometry of the nozzle housing fluidically optimized for pulsed operation
- Positioning takes place via the attached dovetail
- Nozzle sizes and spray angles identical to standard nozzle series 652



Series 652.xxx.16.56

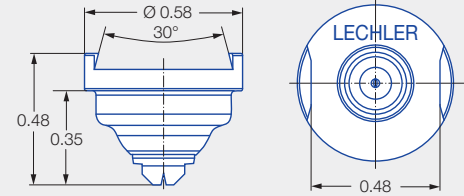

Type	Nozzle size up to	Spray character	Spray angle	Material
652.xxx.16.56	64x	Flat fan	Page 212	303 SS

Please refer to the data of series 652 on w for the nozzle size (flow rate and spray angle).

Ordering Type + Nozzle size = Ordering no.
example: 652.xxx.16.56 + 301 = 652.301.16.56

» ACCESSORIES

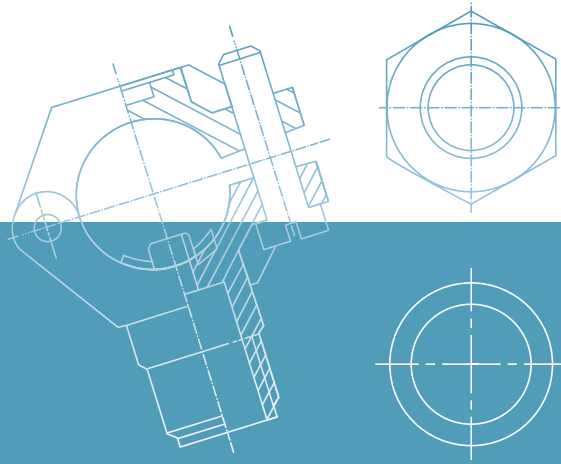

NOZZLE FASTENING ASSEMBLING OPTIONS FOR ALL PURPOSES



Assembly accessories for nozzle tips or nozzles with female thread

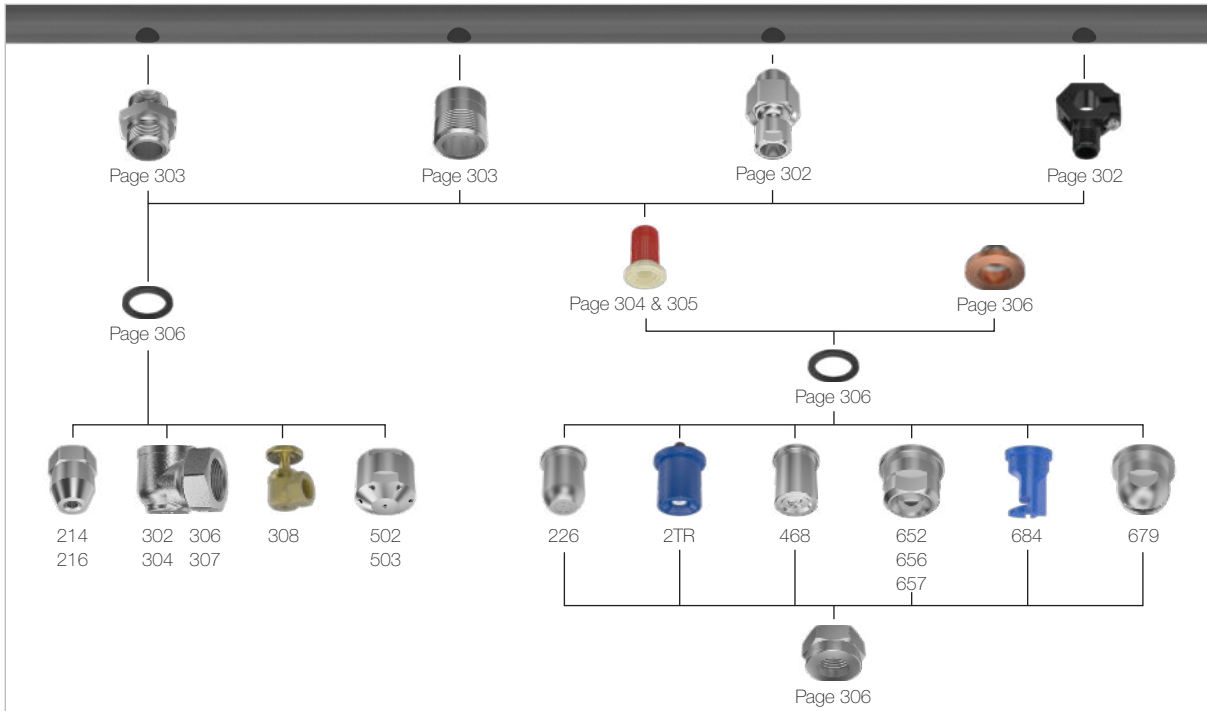

Bayonet quick-release system for nozzle tips or nozzles with bayonet connection

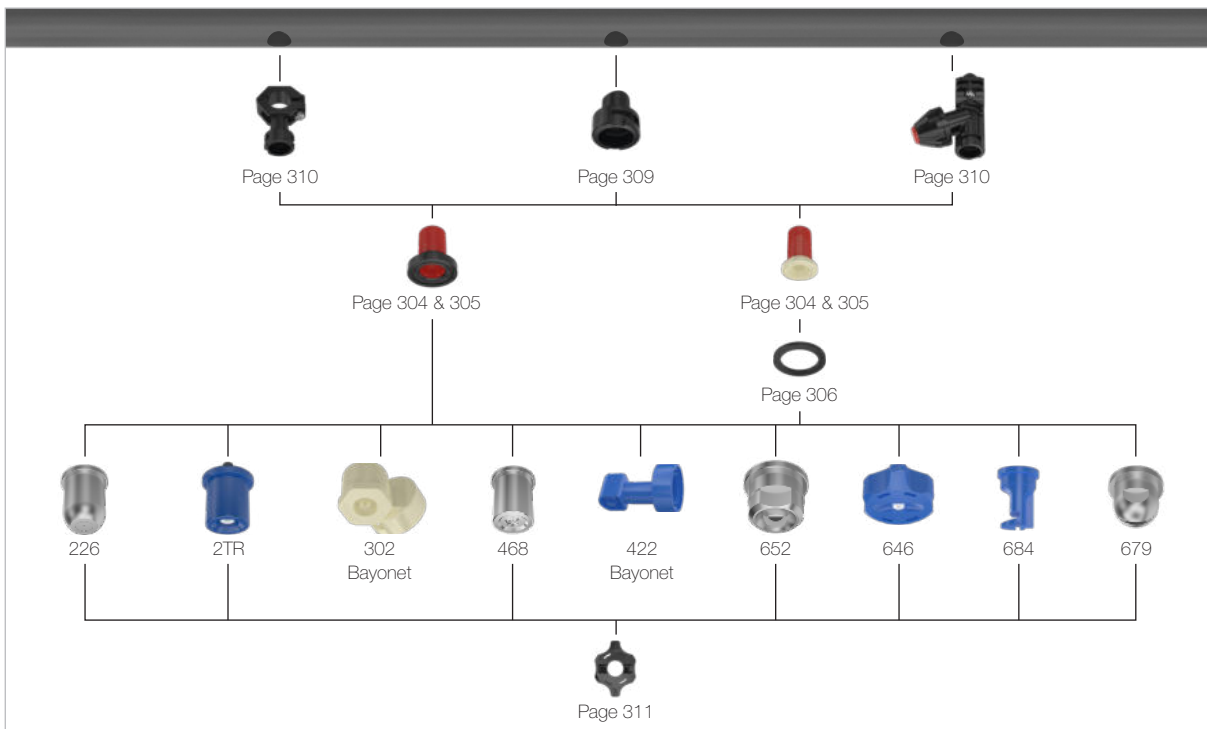

Bayonet quick-release system with ball joint for nozzles with male BSPP thread

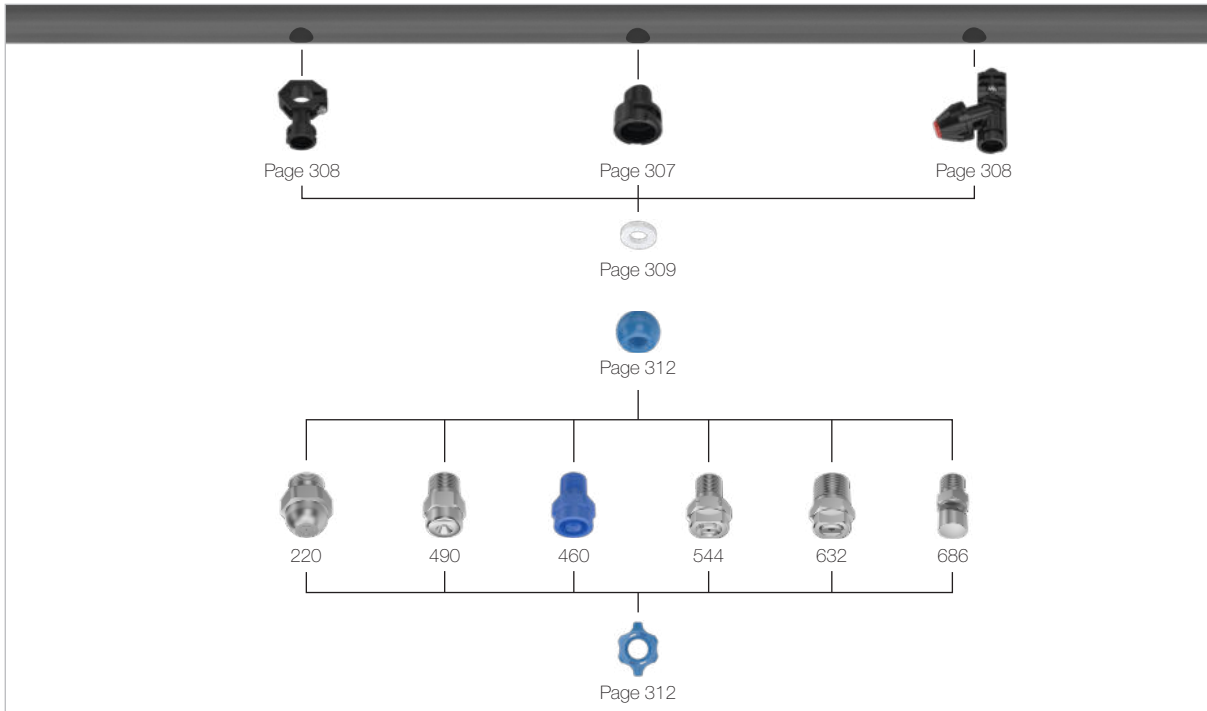

Assembly accessories for nozzles with male thread

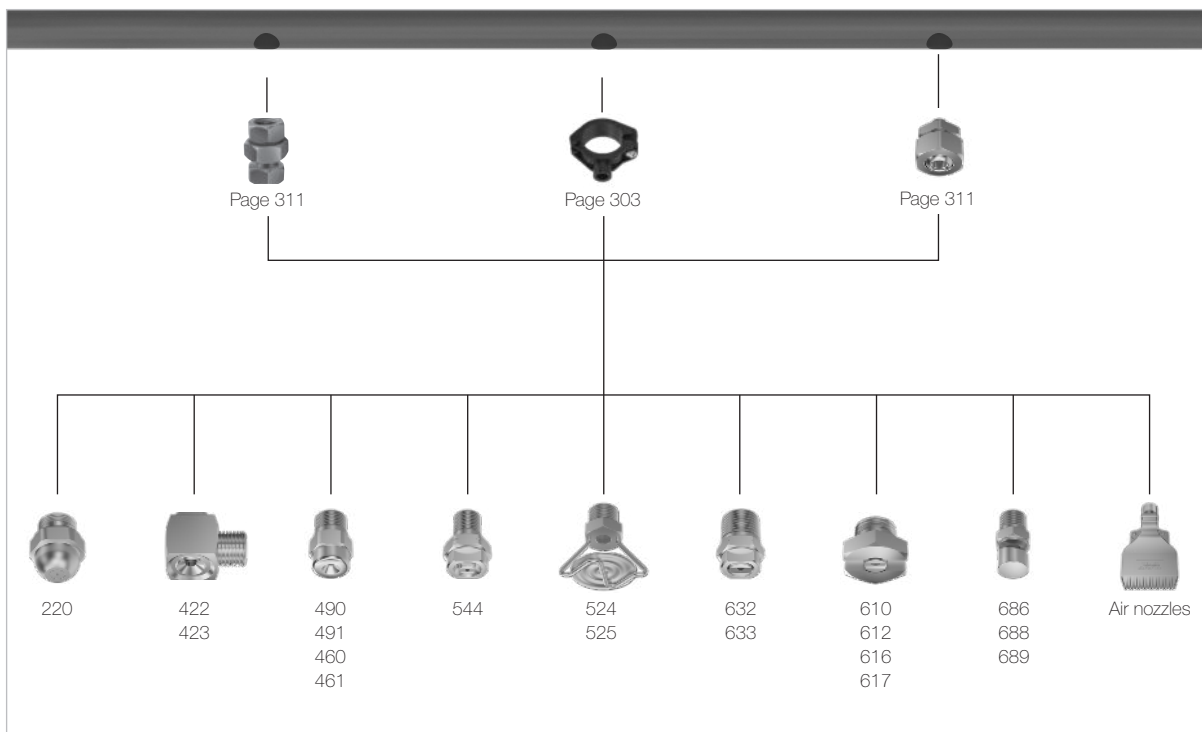



Assembly accessories for nozzles with dovetail version

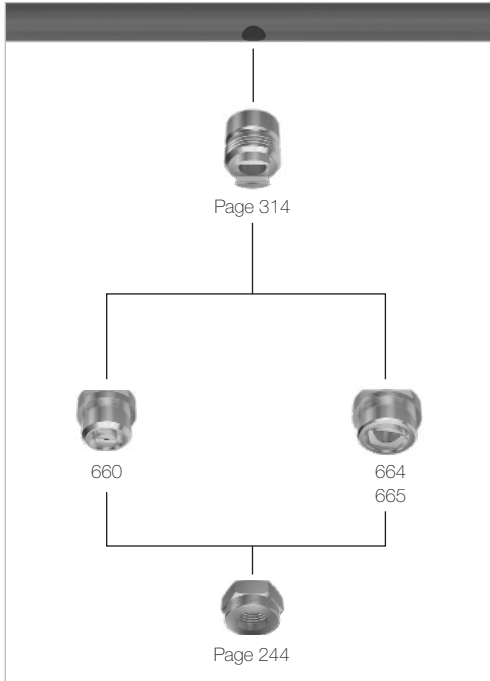

Assembly accessories for nozzles with integrated ball joint

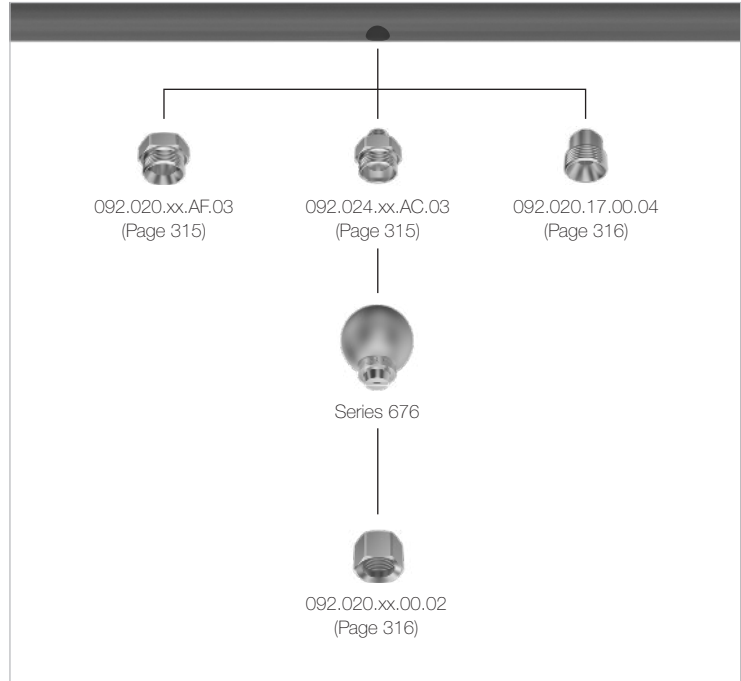

TWISTLOC quick-release system for nozzles without thread

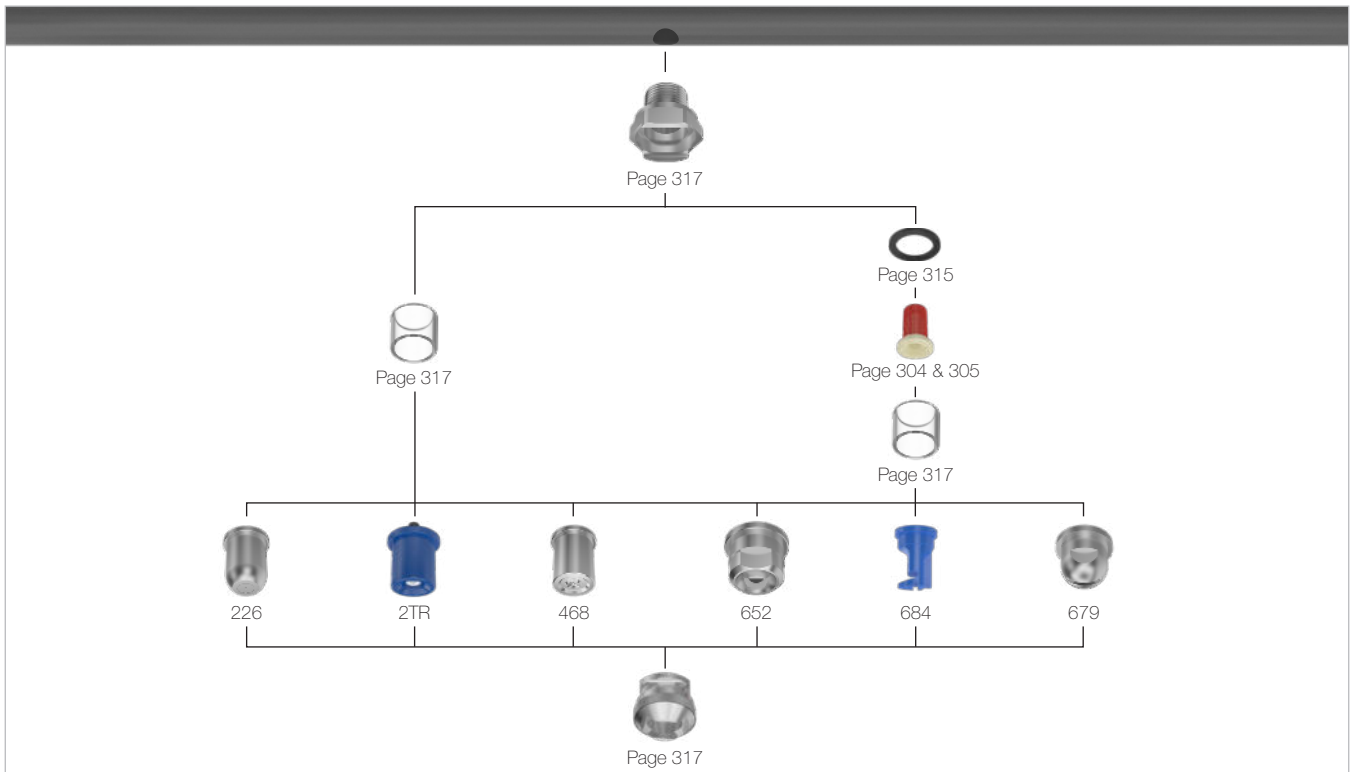



Assembly accessories for nozzle tips or nozzles with BSPP female thread



Welded nipple

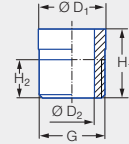

Series	Ordering number				G Male BSPP	Dimensions [in]				Weight [lb] (Brass)	
	Type	Mat. no.				H ₁	H ₂	Ø D ₁	Ø D ₂		
		02	17	30							53
226/216/2TR/302/308/350/468/652/684/548/679	065.210	●	●	●	●	3/8	.59	.39	.68	.45	.04
306/307/502/503/656/657	065.610	●	●		●	3/4	1.06	.55	1.10	.71	.13

Welded nipple with radius

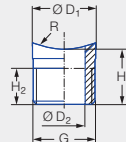

Series	Ordering number		G Male BSPP	Dimensions [in]				Weight [lb]
	Type	Mat. no.		H ₁	H ₂	Ø D ₁	Ø D ₂	
		17						
226/216/2TR/302/308/350/468/652/684/548/679	065.217.17.yy ¹	●	3/8	.59	.39	.68	.45	.04
306/307/502/503/656/657	065.612.17.yy ¹	●	3/4	.91	.55	1.10	.71	.13

¹ Replace "yy" with the desired radius R (R = 10/13/16/20/25 or 31 mm)

Double nipple

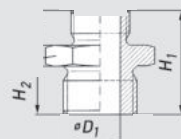

Series	Ordering number			Inlet Male NPT	Outlet Male BSPP	Dimensions [in]				Weight [lb] (Brass)
	Type	Mat. no.				H ₁	H ₂	Ø D ₁	Hex (mm)	
		17	30							
226/216/2TR/302/308/350/468/652/684/548/679	065.215.xx.11	●	●	1/4	3/8	1.44	.56	-	22	.06
	065.215.xx.12	●	●	3/8	3/8	1.38	.50	-	22	.06
	065.215.xx.10	●	●	1/4	UNF 11/16	1.44	.56	-	22	.06
	065.211.xx.10	●	●	3/8	UNF 11/16	1.25	.50	-	22	.06
306/307/502/503/656/657	065.611.xx.BK	●	●	3/4	3/4	1.65	.55	.71	32	.20

Ordering Type + Material no. = Ordering no.
example: 065.215.xx.11 + 17 = 065.215.17.11

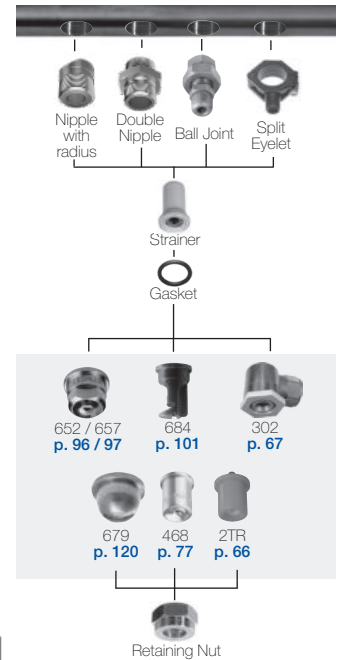

Assembly accessories for nozzle tips or nozzles with female threads.

Assembly accessories for nozzle tips or nozzles with female thread



Ball joints with male thread

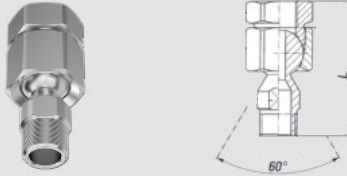

Series	Ordering number			Inlet Female NPT	Outlet Male NPT	Dimensions [in]		Weight [lb] (Brass)
	Type	Mat. no.				Largest Hex (mm)	L	
		16	30					
226/216/2TR/ 302/308/350/ 468/652/684/ 548/679	092.022.xx.BE. BD	●		1/4	3/8	27	2.51	.18
	091.124.xx.BE. BF	●	●	3/8	3/8	27	2.10	.19

Eyelet clamps with male thread

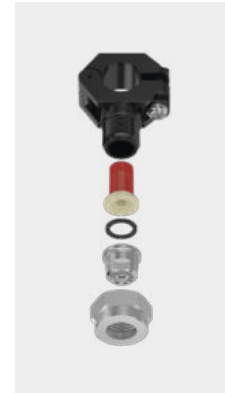
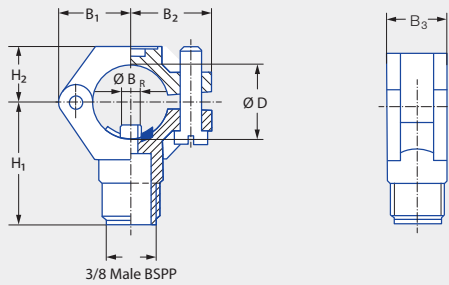

Series	Ordering number			Screw (material)	Pipe Ø	Drill hole diameter	Dimensions [in]							Weight [lb] (polyamide)		
	Type	Mat. no.					Ø B _R ¹	Ø B _R ²	Ø D	B ₁	B ₂	B ₃	H ₁		H ₂	
		51 Black	53 White													5E Blue
226/2TR/ 216/302/ 308/350/468/ 652/679/684	090.053	●	●	●	Stainless steel 304	3/8"	1/4"	.24	.24-.25	.64-.71	.75	.87	0.73	1.36	0.57	.05
	090.003	●	●	●		1/2"	1/4"	.24	.24-.25	.78-.86	0.83	.94	0.73	1.44	0.65	.05
	090.013	●	●	●		3/4"	5/16"	.30	.30-.31	.98-1.08	0.96	1.05	0.87	1.56	0.69	.06
	090.023	●	●	●		1"	7/16"	.42	.42-.43	1.2-1.4	1.18	1.22	0.87	1.73	0.83	.07
	090.033	●	●	●		1 1/4"	1/2"	.50	.50-.51	1.6-1.7	1.34	1.34	0.98	1.89	0.98	.09

¹ Ø B_R = spigot diameter.

² Ø B = recommended bore diameter.

Ordering Type + Material no. = Ordering no.
example: 090.053 + 51 = 090.053.51

Assembly accessories for nozzle tips or nozzles with male BSPP thread



Eyelet clamps with female thread

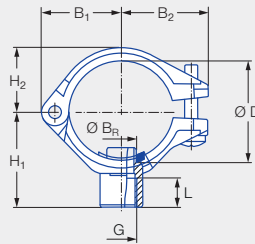

For all nozzles with	Ordering number						Screw (material)	Pipe Ø	Dimensions [in]									Weight [lb] (polyamide)
	Type	Mat. no.			Conn.				B ₁	B ₂	B ₃	H ₁	H ₂	L	Ø B _R ¹	Ø B ²	Ø D	
		51 Black	53 White	5E Blue														
Male thread	090.100	●	●	●	AB	AD	Stainless steel 316	3/8"	0.79	0.91	0.73	1.10	0.55	0.47	0.24	.24-.25	.64-.71	.04
1/8 BSPP	090.110	●	●	●	AB	AD		1/2"	0.87	0.98	0.73	1.22	0.63	0.47	0.24	.24-.25	.78-.86	.04
1/4 BSPP	090.120	●	●	●	AB	AD		3/4"	0.98	1.10	0.87	1.30	0.75	0.47	0.30	.30-.31	.98-1.08	.05
	090.130	●	●	●	AB	AD		1"	1.18	1.30	0.87	1.42	0.91	0.47	0.42	.42-.43	1.2-1.4	.07
	090.140	●	●	●	AB	AD		1 1/4"	1.34	1.46	0.98	1.57	1.10	0.47	0.50	.50-.51	1.6-1.7	.08

¹ Ø B_R = spigot diameter.

² Ø B = recommended bore diameter.

Ordering Type + Material no. + Code = Ordering no.
 example: 090.100 + 51 + AB = 090.100.51.AB

Assembly accessories for nozzle tips, bayonet and female thread



Filter

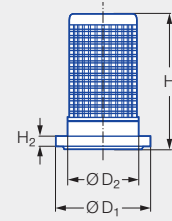

Series	Nozzle size	Ordering number		Color	Dimensions [in]					Weight [lb]
		Type	Mat. no.		Mesh size (mm)	H ₁	H ₂	Ø D ₁	Ø D ₂	
			56							
		POM								
216/2TR/ 302/468/ 422 bayonet/ 652/646/684	xxx.32x-xxx.44x	065.257	●	Blue	60	.84	.08	.58	.43	.04
	xxx.48x-xxx.56x	065.256	●	Red	25	.84	.08	.58	.43	.04

Filter

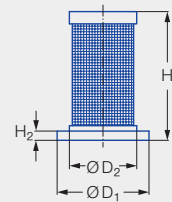

Series	Nozzle size	Ordering number		Color	Dimensions [in]					Weight [lb]
		Type	Mat. no.		Mesh size (mm)	H ₁	H ₂	Ø D ₁	Ø D ₂	
			53							
		Polypropylene								
216/2TR/ 302/468/ 422 bayonet/ 652/646/684	xxx.32x-xxx.44x	095.016.53.15.62	●	Light pink	170	.83	.06	.59	.43	.002
		Strainer insert 304 SS								

Cup strainer

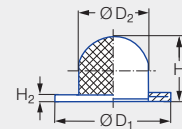

Series	Nozzle size	Ordering number		Mesh size (mm)	Dimensions [in]					Weight [lb]
		Type	Mat. no.		H ₁	H ₂	Ø D ₁	Ø D ₂		
			26							
		Monel/Copper								
216/2TR/ 302/468/ 422 bayonet/ 652/646/684	xxx.32x-xxx.44x	065.252	●	35	.33	.06	.58	.35	.002	

Ordering Type + Material no. = Ordering no.
example: 065.257 + 56 = 065.257.56

Assembly accessories for nozzle tips, bayonet and female thread



Ball-type non-return valve with integrated filter
 $p_{max} = 20 \text{ bar}$

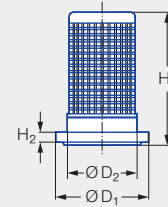

Series	Nozzle size	Ordering number		Color	Pressure [psi]		Dimensions [in]				Weight [lb]	
		Type	Mat. no.		Opening pressure	Closing pressure	Mesh size (mm)	H ₁	H ₂	Ø D ₁		Ø D ₂
			56									
216/2TR/ 302/468/ 422 bayonet/ 652/646/684	xxx.32x-xxx.44x	065.265 Ball 420 SS Spring 302 SS	●	Blue	6-7	5-7	50	.84	.08	.60	.43	.004
	xxx.48x-xxx.56x	065.266 Ball 420 SS Spring 302 SS	●	Red	6-7	5-7	25	.84	.08	.60	.43	.004

Ball-type non-return valve with integrated filter

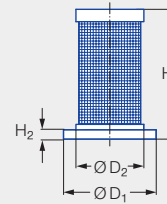

Series	Nozzle size	Ordering number		Color	Pressure [psi]		Dimensions [in]				Weight [lb]	
		Type	Mat. no.		Opening pressure	Closing pressure	Mesh size (mm)	H ₁	H ₂	Ø D ₁		Ø D ₂
			53									
216/2TR/ 302/468/ 422 bayonet/ 652/646/684	xxx.14x-xxx.36x	095.016.53.11.00 Strainer insert/ Ball 304 SS Spring 302 SS	●	Blue	approx. 7	approx. 3	170	.83	.06	.60	.43	.004
	xxx.14x-xxx.36x	095.016.53.14.63 Strainer insert/ Ball 304 SS Spring 302 SS	●	Green	approx. 41	approx. 23	170	.83	.06	.60	.43	.004

Ordering Type + Material no. = Ordering no.
 example: 065.265 + 56 = 065.265.56

Assembly accessories for nozzle tips and female thread



Gaskets

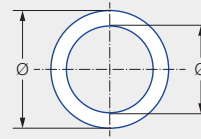

Series	Nozzle Code	Ordering number				Dimensions [in]	Weight [lb]	
		Type	Mat. no.					
			55 PTFE	71 Cu. ISO PL. 7504	72 EWP 210 (asbestos-free)			73 Soft rubber
610	1/8 BSPP	061.040				Ø .39 x Ø .55 x .04	.0002	
220/612	1/4 BSPP	061.240	●	● ¹	●	Ø .52 x Ø .67 x .04	.0004	
490/491/ 460/461/ 616/617/689	3/4 BSPP	061.640		● ²	●	Ø 1.04 x Ø 1.26 x .04	.001	
405	1 1/4 BSPP	062.140			●	Ø 1.65 x Ø 1.97 x .04	.002	
405	2 BSPP	062.540			●	Ø 2.36 x Ø 2.76 x .08	.008	
226/468/652/ 684/679	Retaining nut 3/8	065.240	●		●	Ø .43 x Ø .59 x .04	.0003	
656/657	Retaining nut 3/4	065.640			●	Ø .71 x Ø .94 x .04	.001	

¹ Dimensions [in] for mat. no. 71: .52 x .67 x .08.

² Dimensions [in] for mat. no. 71: 1.04 x 1.26 x .10.

Retaining nuts

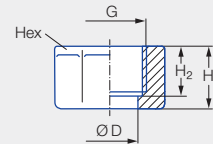
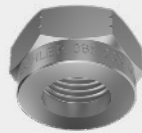

Series	Ordering number							G BSPP	Dimensions [in]				Weight [lb] (Brass)
	Type	Mat. no.							H ₁	H ₂	Ø D	Hex (mm)	
		16 Stainless steel 303	17 ¹ Stainless steel 316Ti	1Y Stainless steel 316L	30 Brass	56 Black POM	5E Blue PVDF						
226/2TR/ 468/652/660/ 684/548/679	065.200	●	●		●			3/8	0.51	0.39	0.50	22	.05
	065.200					●	●	3/8	0.57	0.45	0.51	22	.05
	069.000	●		●	●			UNF 11/16	0.56	0.38	0.52	22	.05
656/657/ 664/665	065.600	●	●		●		●	3/4	0.63	0.51	0.79	32	.13

¹ We reserve the right to supply material 316Ti or 316L under material no. 17.

Ordering Type + Material no. = Ordering no.
example: 065.200 + 16 = 065.200.16

Assembly accessories for nozzle tips or nozzles with female thread

Bayonet quick release system



Bayonet threaded nipple

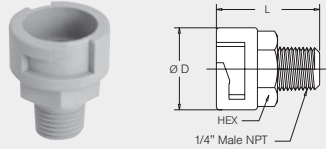

Series	Ordering number			Dimensions [in]			Weight [lb]
	Type	Mat. no.		L	R	Hex (mm)	
		PP	Connection				
302 bay, 422 bay, 2TR, 468, 652, 679, 684	090.075.53.00	●	1/4" Male NPT	1.29	1.02	20	.01

Bayonet welded nipple

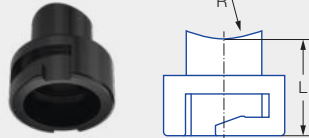

Series	Ordering number			Dimensions [in]		Weight [lb]
	Type	Mat. no.		L	R	
		50	53			
226/2TR/302 bayonet/ 422 bayonet/468/ 652/646/684/679	095.016.xx.08.05¹	●	●	.98	.63	.01

¹ Replace "xx" with the desired material no.

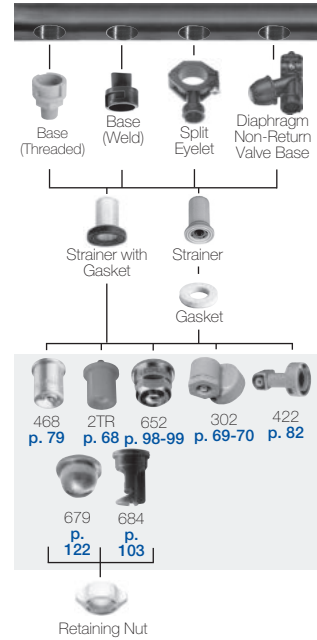

Assembly accessories for nozzle tips or nozzles with female threads. Bayonet quick release system.

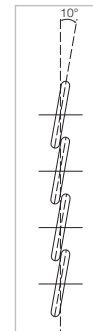

Twist angle to the right in relation to the pipe axis. Twist angle 10°. Other twist angles available on request.

Assembly accessories for nozzle tips or nozzles with female thread

Bayonet quick release system



Eyelet clamps with bayonet quick-release system

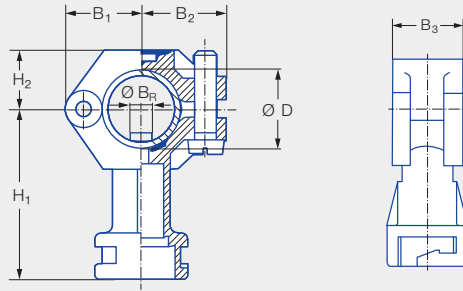

Series	Ordering number				Screw (material)	Pipe Ø	Dimensions [in]							Weight [lb] (Polyamide)		
	Type	Mat. no.					Bayonet	B ₁	B ₂	B ₃	H ₁	H ₂	Ø B _R ¹		Ø B ²	Ø D
		51 Black Polyamide	53 White Polypropylene	5E Blue PVDF												
226/2TR/ 302 bayonet/ 422 bayonet/ 468/652/646/ 684/679	090.003	●	●	●	KA	Stainless steel 304	1/2"	0.83	0.94	0.73	1.95	0.65	0.24	.24-.25	.79-.87	.05
	090.013	●	●	●	KA		3/4"	0.96	1.04	0.87	2.07	0.69	0.30	.30-.31	.98-1.08	.06
	090.023	●	●	●	KA		1"	1.18	1.22	0.87	2.24	0.83	0.42	.42-.43	1.26-1.36	.07

¹ Ø B_R = spigot diameter.

² Ø B = recommended bore diameter.

Diaphragm non-return valve with bayonet quick-release system

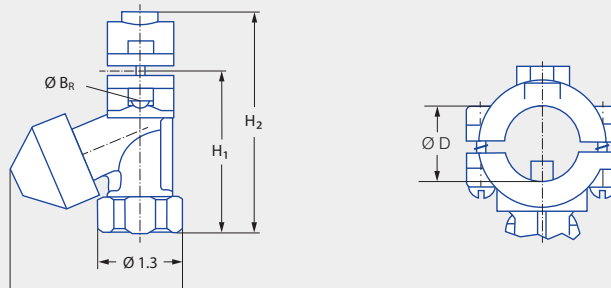

Series	Ordering number			Screw (material)	Pipe Ø	Ø D [in]	Pressure [psi]		Dimensions [in]				Weight [lb]
	Type	Mat. no.	Connection				Opening pressure	Closing pressure	H ₁	H ₂	Ø B _R ¹	Ø B ²	
		56 Black POM											
226/2TR/ 302 bayonet/ 422 bayonet/ 468/652/646/ 684/679	065.272	●	KH	Stainless steel 303	1/2"	.78-.86	12	9	2.32	3.31	0.24	.24-.25	.11
	065.272	●	KL		3/4"	.98-1.08	12	9	2.60	3.54	0.38	.38-.39	.12

¹ Ø B_R = spigot diameter.

² Ø B = recommended bore diameter.

Material	Max. temperature [°F]	Max. pressure [psi]
PA, PP, PVDF, POM	149	145
PA, PP, PVDF, POM	176	116
PVDF	212	58

Notice: Please consider the material combination when using bayonet eyelet clamps with bayonet quick-release system nuts. The nuts may be difficult to turn when using different materials.

Assembly accessories for bayonet quick release system



Gaskets



Ordering number	Description		Weight [lb]
Type			
095.015.7J.01.65	Santoprene	Replacement gasket for use with strainer	.016
065.242.73.00.00	Rubber	Replacement gasket	.016

Bayonet quick-release system nuts

Incl. gasket 065.242.73 (material: Rubber)

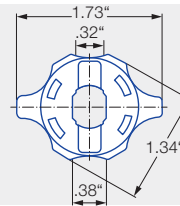

Series	Ordering number			Color	Weight [lb]	
	Type	Mat. no.				
		POM	Polypropylene	PVDF		
652/679	065.202.56.00	●			Red	.022
	065.202.53.00		●		Grey	.022
	065.202.5E.00*			●	Blue	.022

*Does not work with 095.075.53.00.0 base includes gasket 065.242.7A (Viton)

Bayonet quick-release system nuts

Incl. gasket 065.242.73 (material: Rubber)

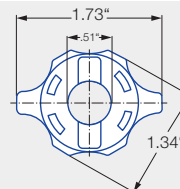

Series	Ordering number		Color	Weight [lb]	
	Type	Mat. no.			
		POM	Polypropylene		
226/2TR/ 468/684	065.202.56.11	●		Black	.022
	065.202.53.11		●	Grey	.022

Notice: Please consider the material combination when using bayonet eyelet clamps with bayonet quick-release system nuts. The nuts may be difficult to turn when using different materials.

Assembly accessories for bayonet quick release system



Ball joint for eyelet clamps with bayonet quick-release system

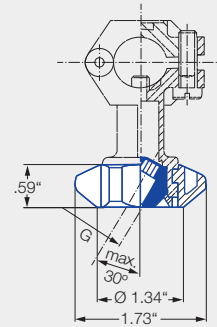

For all nozzles with 1/8" or 1/4" male thread	Ordering number				Color	Weight [oz]
	Type	Mat. no.	Connection			
		PVDF	1/8 BSPP	1/4 BSPP		
Ball joint	092.150	5E	AB	AD	Blue	.064

Bayonet quick-release system nut for ball joint

Incl. O-ring
Ordering no. 095.015.7C.04.16.0
(material: 72 NBR 872)

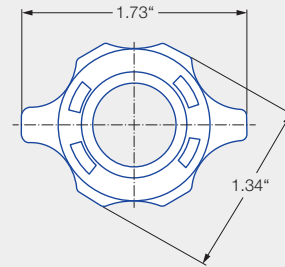

For all nozzles with 1/8" or 1/4" male thread	Ordering number			Color	Weight [oz]
	Type	Mat. no.			
		PVDF			
Quick-release system nut	092.150.5E.00	●		Blue	.16

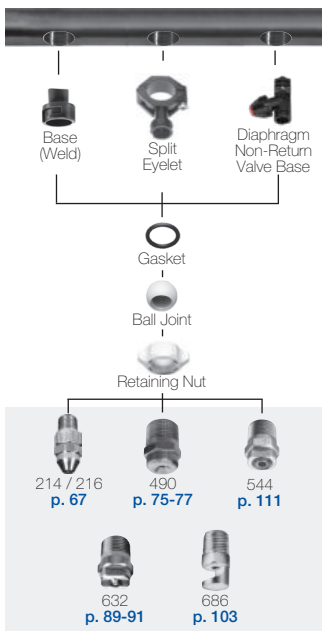

Assembly accessories for bayonet quick release system — male threaded nozzles.

Max. temperature [°F]	Max. pressure [psi]
149	145
176	116
212	58

Ordering Type + Material no. + Code = Ordering no.
example: 092.150 + 5E + AB = 092.150.5E.AB

Assembly accessories for nozzles with male thread



Ball joints

Ball joint with thread connection, female-female

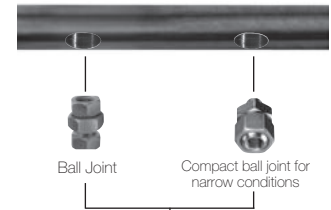
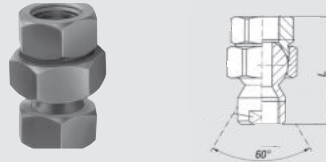

For all series	Ordering number		Inlet NPT Female	Outlet NPT Female	Dimensions [in]		Weight [lb] (Brass)	
	Type	Mat. no.			Largest Hex (mm)	L		
		16						30
422, 490, 544, 632, 686, 696	092.010.xx.BB.BB	●	●	1/8	1/8	22	1.70	.09
	092.020.xx.BD.BD	●	●	1/4	1/4	27	2.37	.13
	092.030.xx.BF.BF	●	●	3/8	3/8	27	2.23	.18

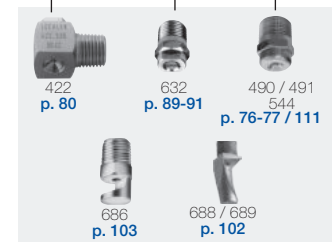

Assembly accessories for nozzles with male threads.

Compact ball joints

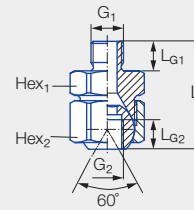

For all nozzles with	Type	Ordering number		Connection	G ₁ Inlet NPT Male	G ₂ Outlet BSPP Female	Dimensions [in]					Weight [lb] (Brass)
		Mat. no.					L	L _{G1}	L _{G2}	Hex ₁ (mm)	Hex ₂ (mm)	
		16	30									
1/8" male thread	092.010	●	●	BA	1/8	1/8	1.15	.31	.31	22	24	2.5
1/4" male thread	092.024	●	●	BC	1/4	1/4	1.73	.47	.47	27	27	4.9
3/8" male thread	092.030	●	●	BE	3/8	3/8	1.73	.47	.47	27	30	5.6

Also available in BSPT inlet CA/CC/CE

Ordering Type + Material no. + Code = Ordering no.
 example: 092.010 + 16 + BA = 092.010.16.BA

Assembly accessories for dovetail nozzles



Welded nipple with dovetail guide

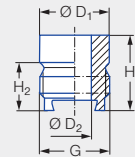

Series	Ordering number		G BSPP	Dimensions [in]				Weight [lb]
	Type	Mat. no.		H ₁	H ₂	Ø D ₁	Ø D ₂	
		17						
660	066.011	●	3/8	0.71	0.45	0.65	0.31	.04
664/665	066.410	●	3/4	1.06	0.61	1.10	0.55	.14

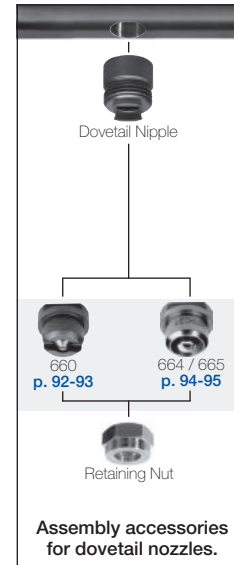

Assembly accessories for dovetail nozzles.

Retaining nuts

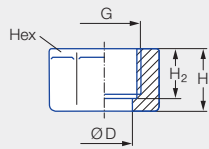
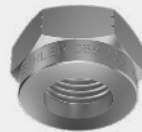

Series	Ordering number				G BSPP	Dimensions [in]				Weight [lb] (Brass)
	Type	Mat. no.				H ₁	H ₂	Ø D	Hex (mm)	
		16	17 ¹	30						
226/2TR/ 468/652/660/ 684/548/679	065.200	●	●	●	3/8	0.51	0.39	0.50	22	.05
656/657/ 664/665	065.600	●	●	●	3/4	0.63	0.51	0.79	32	.13

¹ We reserve the right to supply material 316Ti or 316L under material no. 17.

Dovetail nozzles have an automatic alignment guide which requires a matching dovetail base. Once the base is set, the nozzle can be removed and replaced without need to readjust the alignment. Nozzle is secured to the base with a retaining nut.

Ordering Type + Material no. = Ordering no.
example: 066.011 + 17 = 066.011.17

➤ Accessories for nozzle series 676 with integrated ball joint



Threaded sockets

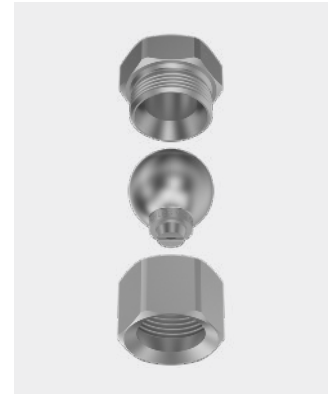
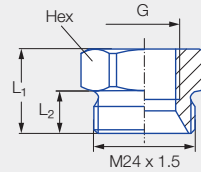

Series	Ordering number		G BSPP	Dimensions [in]			Weight [lb] (Brass)	
	Type	Mat. no.		L ₁	L ₂	Hex (mm)		
		16						30
		Stainless steel 303	Brass					
676	092.020.xx.AF.03 ¹	●	●	3/8	.79	.39	27	.11

¹ Replace "xx" by material no.

Threaded nipple

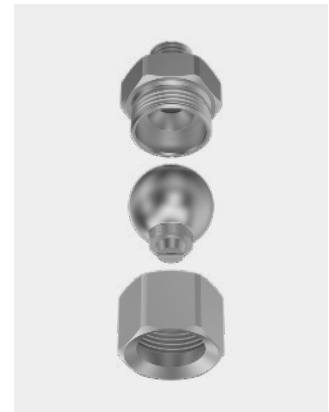
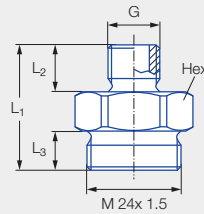

Series	Ordering number		G BSPP	Dimensions [in]				Weight [lb] (Brass)	
	Type	Mat. no.		L ₁	L ₂	L ₃	Hex (mm)		
		16							30
		Stainless steel 303	Brass						
676	092.024.xx.AC.03 ¹	●	●	1/4	1.26	.47	.39	27	.15

¹ Replace "xx" by material no.

Order Type + Material no. = Ordering no.
example: 092.020.xx.AF.03 + 16 = 092.020.16.AF.03

Accessories for nozzle series 676 with integrated ball joint



Welded nipple

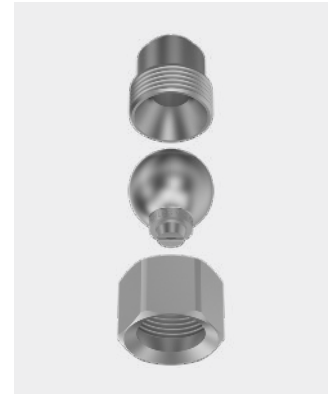
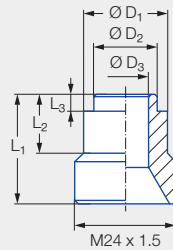

Series	Ordering number		Dimensions [in]						Weight [lb]
	Type	Mat. no.	L ₁	L ₂	L ₃	Ø D ₁	Ø D ₂	Ø D ₃	
		17							
		Stainless steel 316Ti							
676	092.020.17.00.04	●	1.02	.55	.16	.79	.59	.43	.10

Retaining nuts

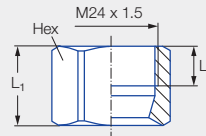
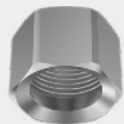

Series	Ordering number				Dimensions [in]			Weight [lb] (Brass)
	Type	Mat. no.		L ₁	L ₂	Hex (mm)		
		16	30					
		Stainless steel 303	Brass					
676	092.020.xx.00.02 ¹	●	●	.79	.39	27	.08	

¹ Replace "xx" by material no.

Notice: The assembly accessories shown can be used with the low pressure flat fan nozzle with ball joint (series 676) (see Page 248/306).

Order Type + Material no. = Ordering no.
example: 092.020.xx.00.02 + 16 = 092.020.16.00.02

» TWISTLOC

Quick-change nozzle system



**Lechler TWISTLOC,
nozzle changing in less than no time.**
Save time and money with the quick-change nozzle system.

- **Quick:**
It takes just one twist to install or remove the nozzle.
- **Easy:**
Can be installed without tools – even in difficult-to-access locations and in bad lighting conditions.
- **Safe:**
Installation errors are avoided, as the nozzles are always set to the correct direction.
- **Max. pressure:**
15 bar.

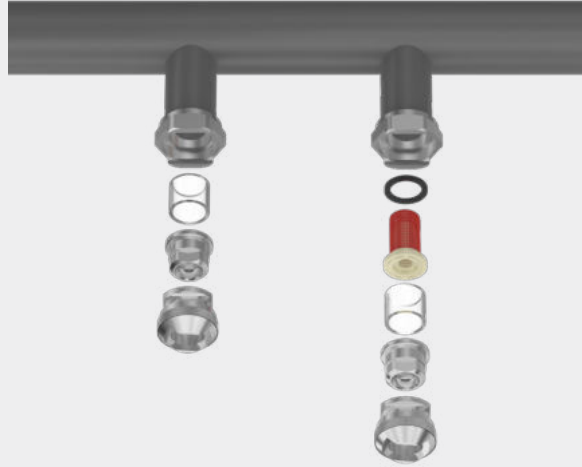

System components		Ordering number							Inner Ø D [in]	Weight [lb]	
		Type	Mat. no.				Connection				
			1C	16	5E	7A	1/4 NPT	3/8 NPT			Welded connec- tion
Threaded nipple		092.102	●				BC		.31	.06	
		092.102	●				BE		.46	.06	
		092.102			●		BE		.31	.02	
Welded nipple		092.104	●					00	.46	.10	
Gasket for material 304 SS and 303 SS		092.113			●				–	.002	
Gasket for material PVDF		092.115			●				–	.002	
Gasket, incl. rubber gasket ring for use with non-return valves or strainers		092.116			●				–	.004	
Gasket, incl. rubber gasket ring for use with non-return valves or strainers, for PVDF material		092.114			●				–	.004	
Quick-release system For nozzle series 652/679		092.106	●	●					–	.04 (stainless steel)	
Quick-release system For nozzle series 226/468/684		092.108	●	●					–	.04 (stainless steel)	



Non-return valves, strainers
For installation in nipples with inner Ø 11.6 mm (see Page 306/307).

Ordering Type + Material no. + Code = Ordering no.
example: 092.102 + 16 + BC = 092.102.16.BC



STAMM®
SHOWER HEADERS

STAMM® SHOWER HEADERS with built-in cleaning device



Engineered and manufactured by Lechler Inc. in the USA under license by the STAMM® Company in Germany, these shower headers with built-in cleaning device are recognized worldwide as the original “brush and flush” shower system.

Shower pipe and nozzles remain clog-free due to the unique flush system design. A simple turn of the handwheel sweeps the contaminants away from the nozzle orifices and directs the debris down the flush-out valve.

Since these showers eliminate costly down time for cleaning, they are especially cost-effective in applications subject to high fluid contamination. Some features of the self-cleaning

shower system are:

- Header pipe available in sizes from 1 1/2" to 6" in diameter.
- Contaminants flushed via special valve, preventing them from clogging orifices or reaching showered surface.
- System accommodates wide range of flow rates.
- Highly efficient, interchangeable nozzles are self-aligning.
- Systems are tailored to your specific application.

Refer to the next page for a selection of nozzles specifically designed for use in STAMM® showers.

Typical applications:

- Cleaning of wires and felts
- Humidification
- Knock-off
- Lubrication

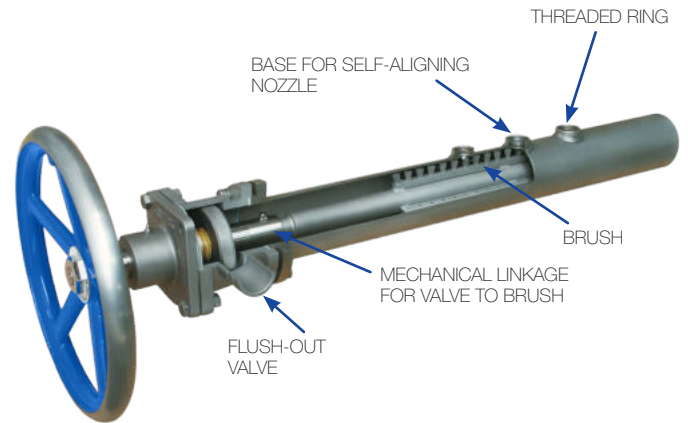

Standard shower models (Other configurations also available; note that models #7–10 have no cleaning device)

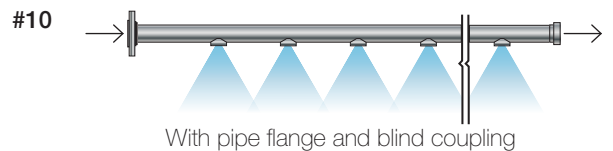
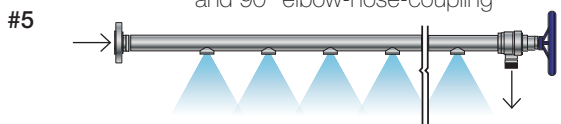
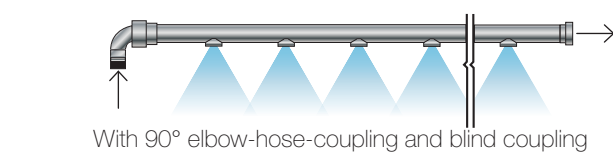
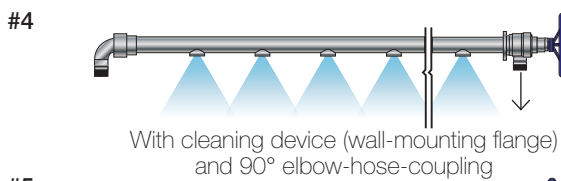
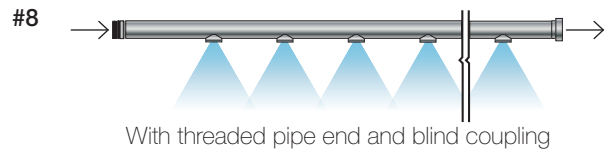
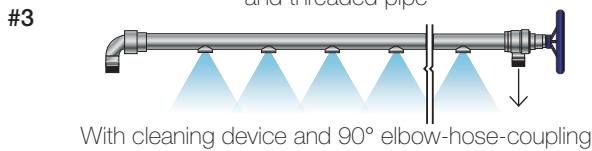
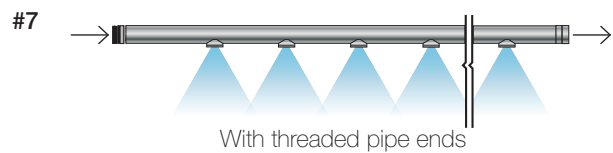
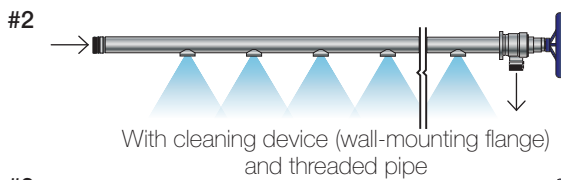
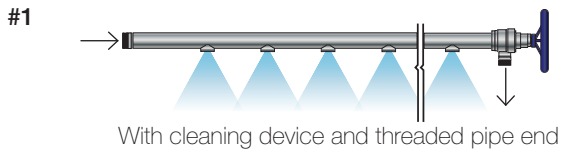

NOZZLES FOR STAMM® SHOWER HEADERS

Series 626 / 5SW



Designed specifically for STAMM® shower headers, these nozzles can serve as replacements or to change the flow rate of an existing unit. Self aligning when used with STAMM® or Lechler bases. 316L SS stainless steel construction for long service life. Available in 75°, 60°, 30°, and 15° flat fans or 0° solid stream ("needle jet") versions.

Applications:

- For use on STAMM® showers
- Paper production
- Belt filter press cleaning in wastewater treatment

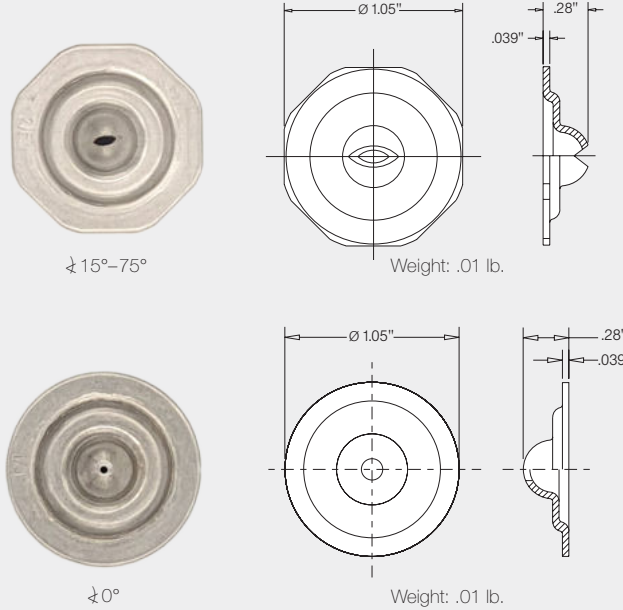

Notes: Also available upon request are: (1) nozzles with other flow rates and (2) solid stream nozzles (0°) with a ruby tip orifice. The number in the Equiv. Orifice Diam. column represents the Nozzle # and spray angle stamped on each nozzle; e.g., the nozzle stamped 1.0 / 60 refers to 626.364.1F.37. Lechler has blank shower nozzles with no orifices which can be used on STAMM® showers when a particular nozzle opening needs to be blocked. The part number for this blank nozzle is **006.261.1F.00**.

Spray angle	Ordering number	Equiv. Orifice Diameter (mm)	V̇ water [gal/min]						
	Material 316L SS stainless steel		p [psij]						
			40	60	100	150	250	500	1000
75°	626. 485. 1E. 37	1.5	.50	.61	.79	.96	1.2	1.8	2.5
	626. 565. 1E. 37	2.0	.77	.95	1.2	1.5	1.9	2.7	3.9
	626. 645. 1E. 37	2.5	1.2	1.5	2.0	2.4	3.1	4.4	6.2
	626. 725. 1E. 37	3.0	2.0	2.4	3.1	3.8	4.9	6.9	9.8
60°	626. 364. 1E. 37	1.0	.20	.24	.31	.38	.49	.69	.98
	626. 404. 1E. 37	1.2	.31	.38	.49	.60	.77	1.1	1.6
	626. 464. 1E. 37	1.5	.50	.61	.79	.96	1.2	1.8	2.5
	626. 564. 1E. 37	2.0	.77	.95	1.2	1.5	1.9	2.7	3.9
	626. 644. 1E. 37	2.5	1.2	1.5	2.0	2.4	3.1	4.4	6.2
	626. 724. 1E. 37	3.0	2.0	2.4	3.1	3.8	4.9	6.9	9.8
	626. 804. 1E. 37	4.0	3.1	3.8	4.9	6.0	7.8	11.0	15.5
	626. 884. 1E. 37	5.0	4.9	6.0	7.8	9.6	12.3	17.4	25.0
	626. 964. 1E. 37	6.0	7.8	9.5	12.3	15.0	19.4	27.0	39.0
	627. 004. 1E. 37	7.0	9.8	12.0	15.5	18.9	24.0	35.0	49.0
627. 044. 1E. 37	8.0	12.4	15.2	19.6	24.0	31.0	44.0	62.0	
30°	626. 362. 1E. 37	1.0	.20	.24	.31	.38	.49	.69	.98
	626. 482. 1E. 37	1.5	.50	.61	.79	.96	1.2	1.8	2.5
	626. 562. 1E. 37	2.0	.77	.95	1.2	1.5	1.9	2.7	3.9
	626. 642. 1E. 37	2.5	1.2	1.5	2.0	2.4	3.1	4.4	6.2
	626. 722. 1E. 37	3.0	2.0	2.4	3.1	3.8	4.9	6.9	9.8
	626. 802. 1E. 37	4.0	3.1	3.8	4.9	6.0	7.8	11.0	15.5
15°	626. 361. 1E. 37	1.0	.20	.24	.31	.38	.49	.69	.98
	626. 561. 1E. 37	2.0	.77	.95	1.2	1.5	1.9	2.7	3.9
	626. 721. 1E. 37	3.0	2.0	2.4	3.1	3.8	4.9	6.9	9.8
	5SW. 300. 1E. 00	0.7	.09	.11	.14	.17	.22	.31	.44
5SW. 320. 1E. 00	0.8	.13	.15	.20	.24	.32	.45	.63	
5SW. 340. 1E. 00	0.9	.15	.19	.25	.30	.39	.55	.77	
5SW. 360. 1E. 00	1.0	.20	.24	.31	.38	.49	.69	.98	
5SW. 390. 1E. 00	1.2	.31	.38	.49	.60	.77	1.1	1.6	
5SW. 460. 1E. 00	1.5	.50	.61	.79	.96	1.2	1.8	2.5	
5SW. 540. 1E. 00	2.0	.77	.95	1.2	1.5	1.9	2.7	3.9	
5SW. 620. 1E. 00	2.5	1.2	1.5	2.0	2.4	3.1	4.4	6.2	
5SW. 680. 1E. 00	3.0	2.0	2.4	3.1	3.8	4.9	6.9	9.8	
5SW. 780. 1E. 00	4.0	3.1	3.8	4.9	6.0	7.8	11.0	15.5	
5SW. 860. 1E. 00	5.0	4.9	6.0	7.8	9.6	12.0	17.4	25.0	

AUTOMATIC CLEANING DEVICE AND OSCILLATORS FOR STAMM® HEADERS

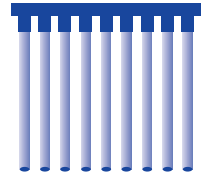

Part number	Description	Stroke length	Shower size
<p>10.900 Automatic Cleaning Device</p> 	<p>Automatic regular cleaning of nozzles at programmable intervals; existing showers can be retrofitted with this device.</p>	<p>N/A</p>	<p>All sizes</p>
<p>10.200 E Oscillator</p> 	<p>Oscillator with electromechanical crank drive for side-to-side movement by a sliding block and axial guide rail.</p>	<p>Non-adjustable 200 mm</p>	
<p>10.010 LE-R Oscillator</p> 	<p>Oscillator with electromechanical gear motor that rotates a double ball screw spindle which converts rotation into linear stroke movement.</p>	<p>2" to 3": 206.4 mm or 301.4 mm 1-120 mm/min</p> <p>4" to 6": 203.2 mm or 304.2 mm</p>	<p>One size for 2" to 3" diameter</p> <p>One size for 4" to 6" diameter</p>
<p>10.020 EC Oscillator</p> 	<p>Oscillator with electromechanical step motor with a planetary gear reducer to drive a ball screw spindle.</p>	<p>Infinitely adjustable 1-200 mm 1-300 mm (optional)</p>	<p>2" to 6"</p>



AUTOMATIC CLEANING DEVICE AND OSCILLATORS FOR STAMM® HEADERS

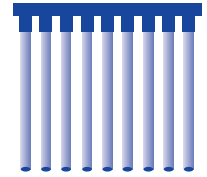

Part number	Description	Stroke length	Shower size	
10.094 Oscillator		Infinitely adjustable 1–200 mm 1–300 mm (optional) 1–500 mm (optional)	2" to 6"	
10.093 Oscillator		Oscillator with oil-hydraulic drive with electronic oil flow control for automatic adjustment of stroke speed.	Infinitely adjustable 1–200 mm 1–300 mm (optional) 1–500 mm (optional)	2" to 6"
10.800 Oscillator bearing		Wear-resistant bearing made of stainless steel; installs in any position and fits all drive alternatives.	N/A	

ENGINEERING
YOUR SPRAY SOLUTION



Lechler, Inc. · Precision Nozzles · Nozzle Systems
445 Kautz Rd. St. Charles, IL 60174 · Phone (800) 777-2926 · info@lechlerusa.com · www.lechlerusa.com